

Project Title :- SHIMPU DEVI

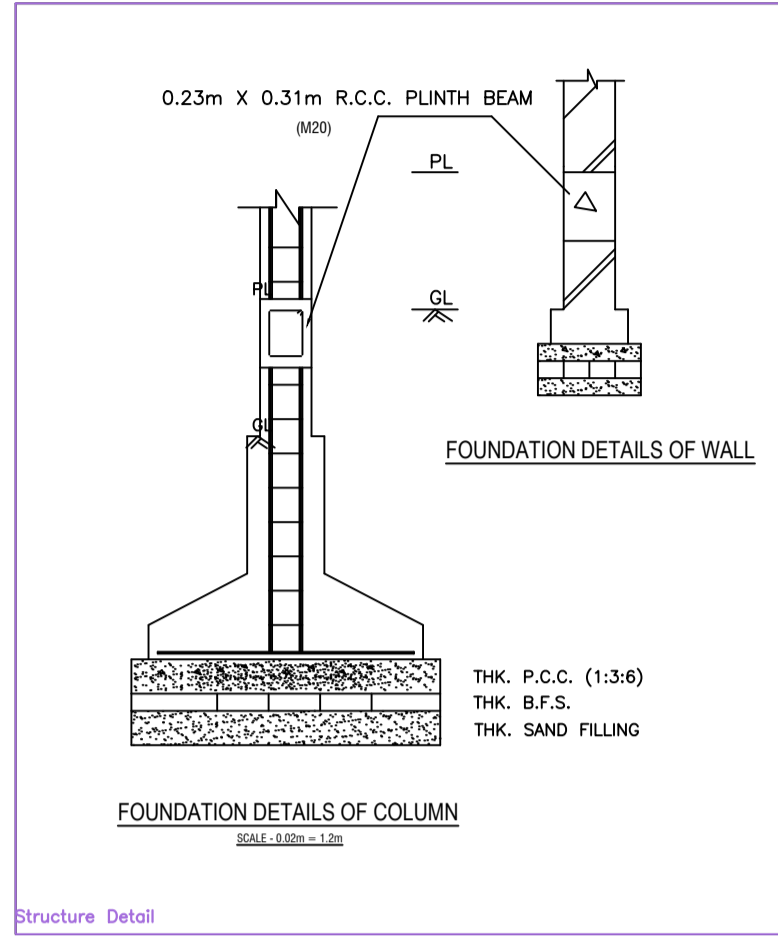

Structure Detail

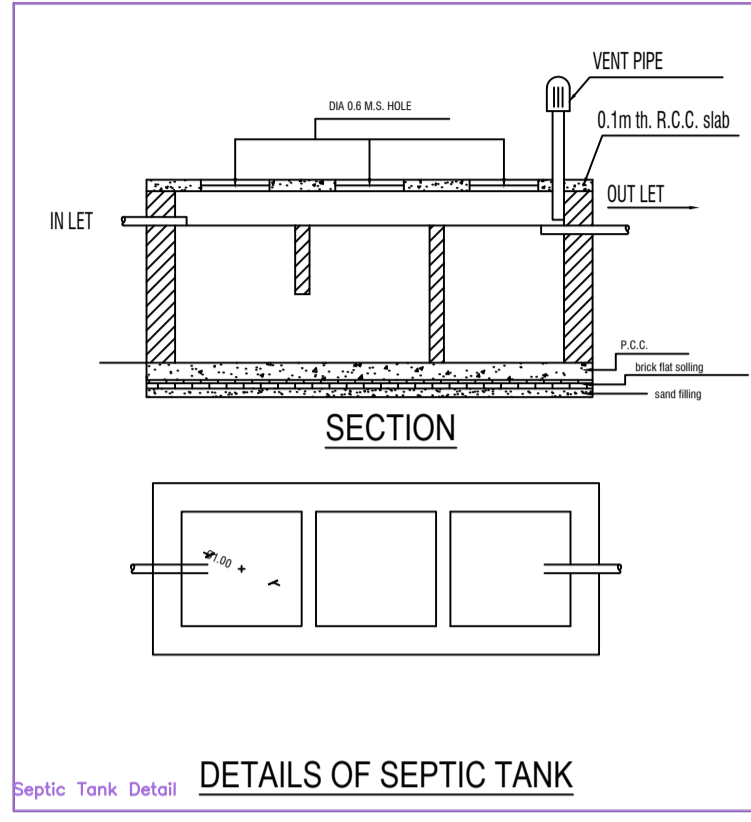

Septic Tank Detail

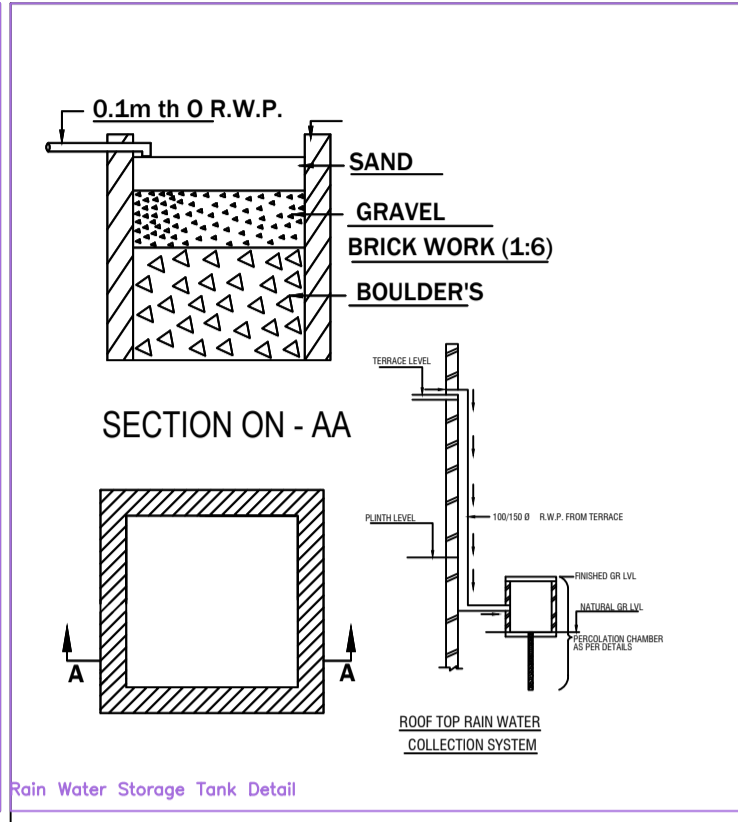

Rain Water Storage Tank Detail

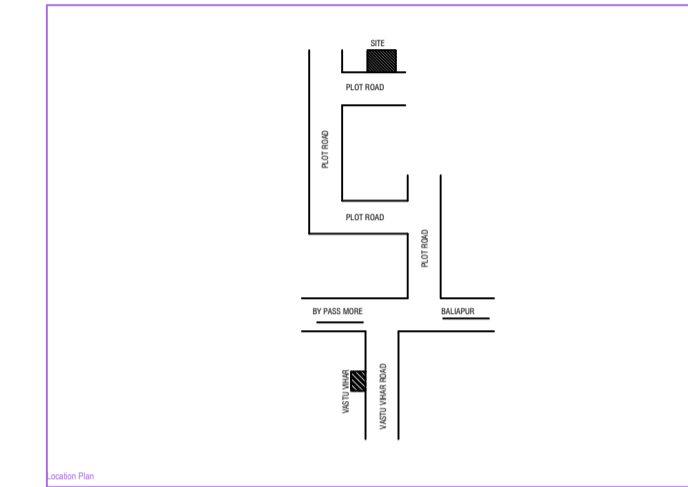
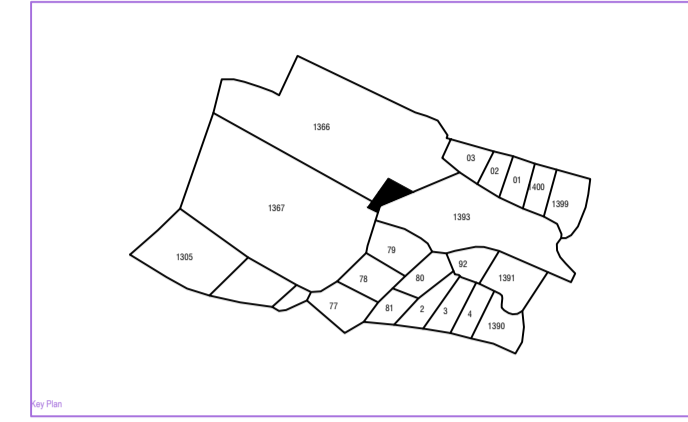

BRIEF SPECIFICATION

- FOUNDATION** :- R.C.C. (1:1.5:3) Column footing foundation.
- PLINTH** :- 12"th R.C.C. (1:1.5:3) all round on plinth level.
- FLOORING** :- 1.5"th Marble. flooring over 3"th P.C.C. (1:3:6).
- SUPER STRUCTURE** :- First class brick work in cement mortar (1:1.5:3).
- SLAB,BEAM, stairs & LINTEL** :- All R.C.C. work (1:1.5:3).
- WOOD WORK** :- All door & window frames of sal wood.
- PLASTERING** :- 12mm cement plaster (1:6) both side.

SCHEDULE

D1 - 1.07 X 2.13	W - 0.9 x 1.22
D2 - 0.9 X 2.13	W1 - 1.22 x 1.22
D3 - 0.76 x 2.13	W2 - 1.5 x 1.22
CG - 1.22 x 2.13	V - 0.61 x 0.61

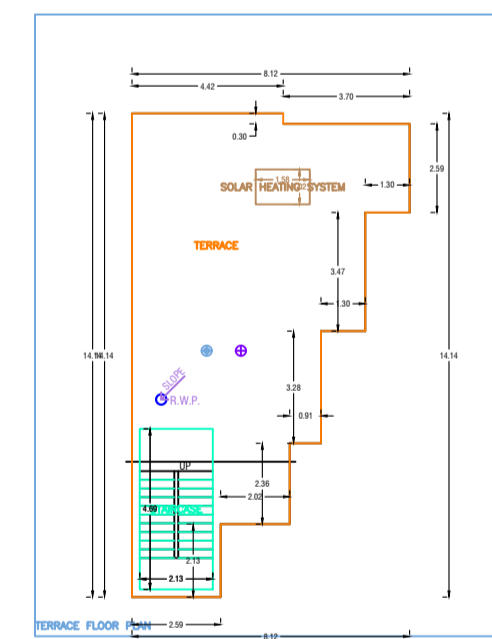
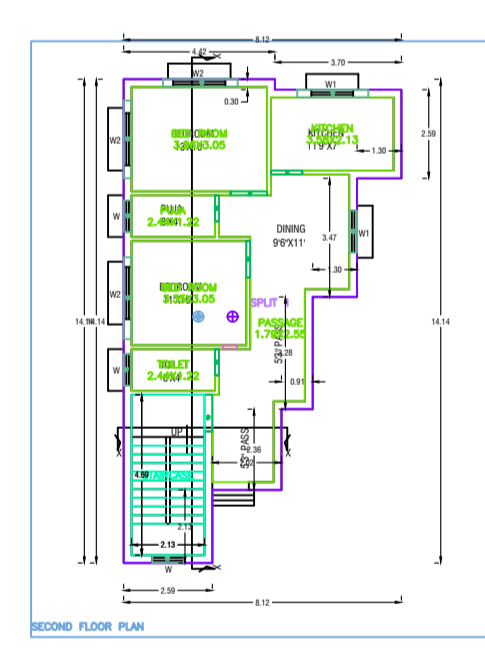
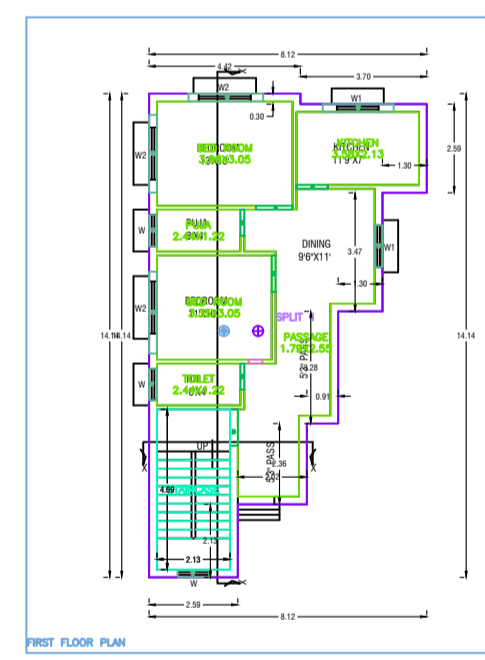
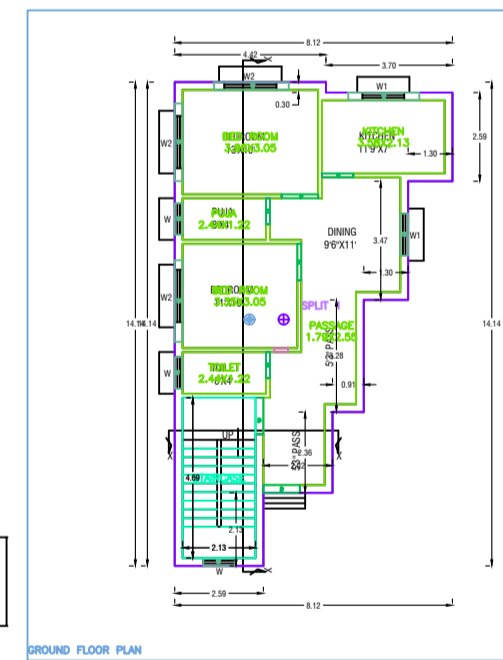
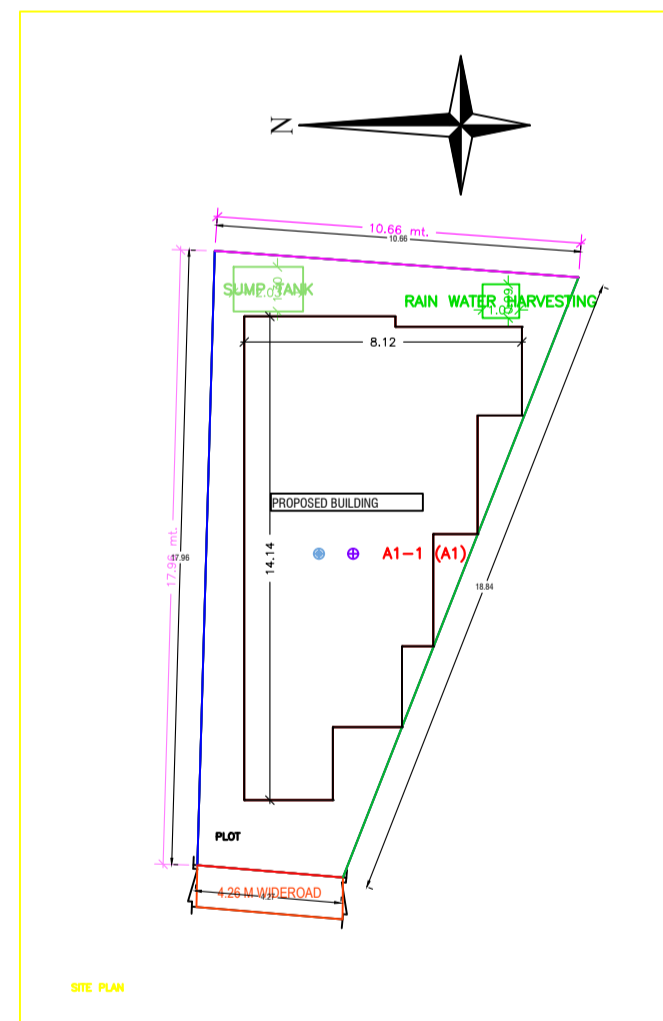
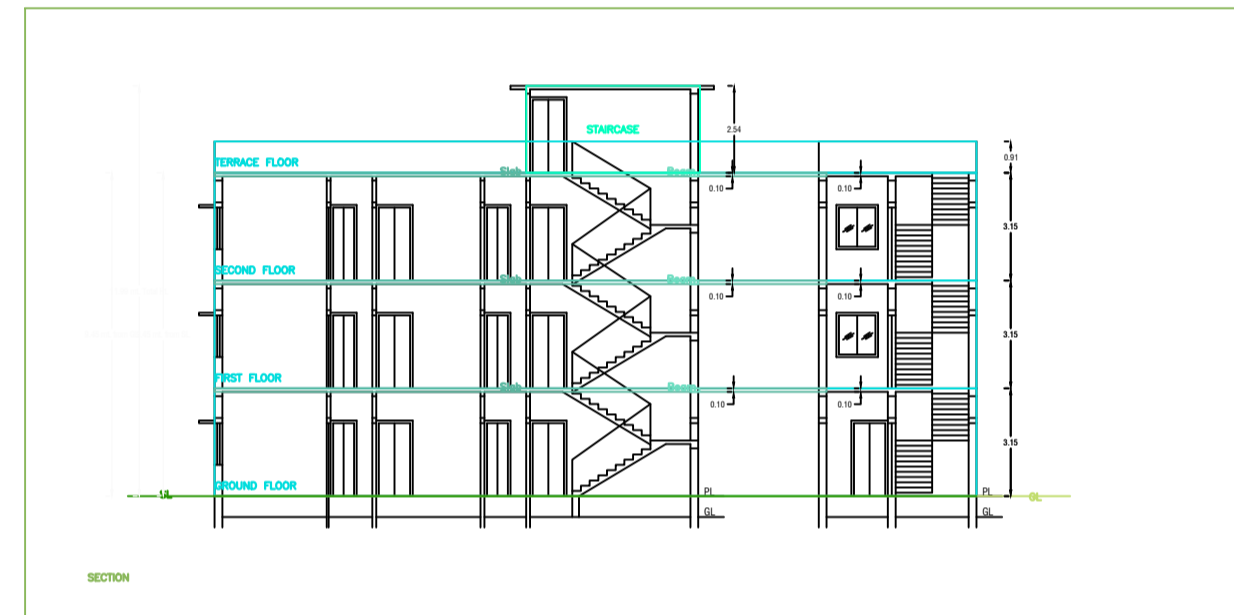
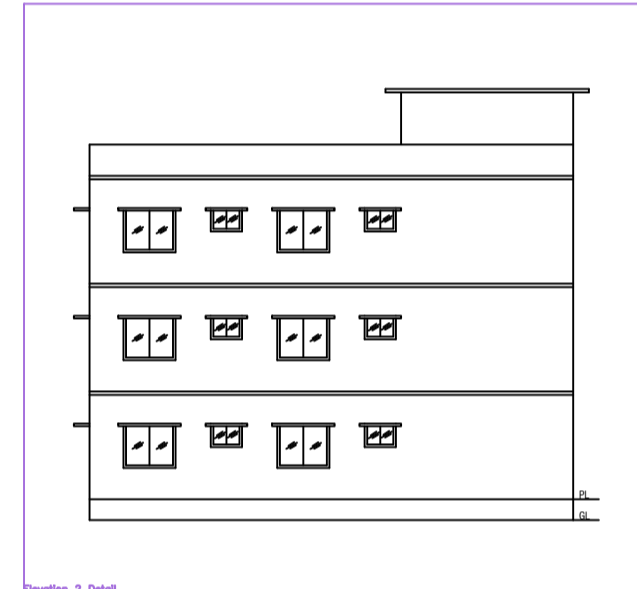
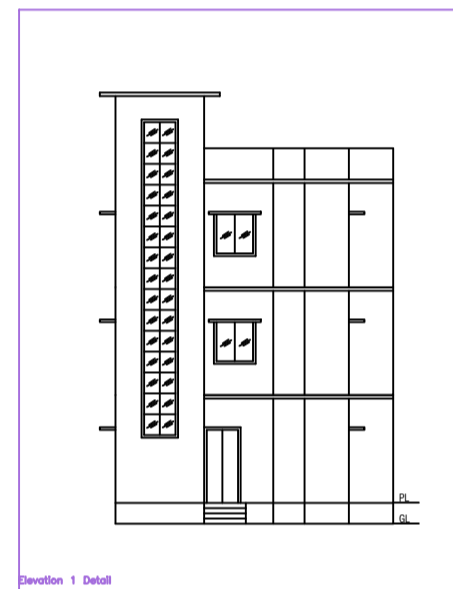

Building A1 (A1)

Room Name	Total Built Area (Sq.Mt)	Permitted Floor Area (Sq.Mt)	Total Floor Area (Sq.Mt)	Total No.
Ground Floor	85.54	85.54	85.54	27
First Floor	85.54	85.54	85.54	27
Second Floor	85.54	85.54	85.54	27
Terrace	100.00	100.00	100.00	37
Plinth	200.00	200.00	200.00	37
Total	356.62	356.62	356.62	128

SCHEDULE OF JOINERY

ITEM	NAME	LENGTH	HEIGHT	NO
W1	W	1.22	2.13	27
W2	W	1.50	2.13	27
W3	W	1.50	2.13	27

SCHEDULE OF JOINERY

ITEM	NAME	LENGTH	HEIGHT	NO
W1	W	1.22	2.13	27
W2	W	1.50	2.13	27
W3	W	1.50	2.13	27

UNITARY Table for Building A1 (A1)

FLOOR	Name	Area	Volume	Cost	No. of Units	Unit Cost
GROUND FLOOR	WALL	200.00	200.00	200.00	4	1
FIRST FLOOR	WALL	200.00	200.00	200.00	4	1
SECOND FLOOR	WALL	200.00	200.00	200.00	4	1

ITEM	DESCRIPTION	UNIT	QUANTITY	RATE	AMOUNT
1	FOUNDATION	SQ.M	356.62	100.00	35662.00
2	PLINTH	SQ.M	356.62	100.00	35662.00
3	FLOORING	SQ.M	356.62	100.00	35662.00
4	WALL	SQ.M	200.00	100.00	20000.00
5	ROOFING	SQ.M	100.00	100.00	10000.00
6	PAINTING	SQ.M	356.62	100.00	35662.00
7	WATER SUPPLY	SQ.M	100.00	100.00	10000.00
8	SEWERAGE	SQ.M	100.00	100.00	10000.00
9	RAINFALL	SQ.M	100.00	100.00	10000.00
10	STAIRS	SQ.M	100.00	100.00	10000.00
11	DOORS	SQ.M	100.00	100.00	10000.00
12	WINDOWS	SQ.M	100.00	100.00	10000.00
13	ROOF TOP RAIN WATER COLLECTION SYSTEM	SQ.M	100.00	100.00	10000.00
14	SEPTIC TANK	SQ.M	100.00	100.00	10000.00
15	RAINFALL	SQ.M	100.00	100.00	10000.00
16	STAIRS	SQ.M	100.00	100.00	10000.00
17	DOORS	SQ.M	100.00	100.00	10000.00
18	WINDOWS	SQ.M	100.00	100.00	10000.00
19	ROOF TOP RAIN WATER COLLECTION SYSTEM	SQ.M	100.00	100.00	10000.00
20	SEPTIC TANK	SQ.M	100.00	100.00	10000.00
21	RAINFALL	SQ.M	100.00	100.00	10000.00
22	STAIRS	SQ.M	100.00	100.00	10000.00
23	DOORS	SQ.M	100.00	100.00	10000.00
24	WINDOWS	SQ.M	100.00	100.00	10000.00
25	ROOF TOP RAIN WATER COLLECTION SYSTEM	SQ.M	100.00	100.00	10000.00
26	SEPTIC TANK	SQ.M	100.00	100.00	10000.00
27	RAINFALL	SQ.M	100.00	100.00	10000.00
28	STAIRS	SQ.M	100.00	100.00	10000.00
29	DOORS	SQ.M	100.00	100.00	10000.00
30	WINDOWS	SQ.M	100.00	100.00	10000.00
31	ROOF TOP RAIN WATER COLLECTION SYSTEM	SQ.M	100.00	100.00	10000.00
32	SEPTIC TANK	SQ.M	100.00	100.00	10000.00
33	RAINFALL	SQ.M	100.00	100.00	10000.00
34	STAIRS	SQ.M	100.00	100.00	10000.00
35	DOORS	SQ.M	100.00	100.00	10000.00
36	WINDOWS	SQ.M	100.00	100.00	10000.00
37	ROOF TOP RAIN WATER COLLECTION SYSTEM	SQ.M	100.00	100.00	10000.00
38	SEPTIC TANK	SQ.M	100.00	100.00	10000.00
39	RAINFALL	SQ.M	100.00	100.00	10000.00
40	STAIRS	SQ.M	100.00	100.00	10000.00
41	DOORS	SQ.M	100.00	100.00	10000.00
42	WINDOWS	SQ.M	100.00	100.00	10000.00
43	ROOF TOP RAIN WATER COLLECTION SYSTEM	SQ.M	100.00	100.00	10000.00
44	SEPTIC TANK	SQ.M	100.00	100.00	10000.00
45	RAINFALL	SQ.M	100.00	100.00	10000.00
46	STAIRS	SQ.M	100.00	100.00	10000.00
47	DOORS	SQ.M	100.00	100.00	10000.00
48	WINDOWS	SQ.M	100.00	100.00	10000.00
49	ROOF TOP RAIN WATER COLLECTION SYSTEM	SQ.M	100.00	100.00	10000.00
50	SEPTIC TANK	SQ.M	100.00	100.00	10000.00
51	RAINFALL	SQ.M	100.00	100.00	10000.00
52	STAIRS	SQ.M	100.00	100.00	10000.00
53	DOORS	SQ.M	100.00	100.00	10000.00
54	WINDOWS	SQ.M	100.00	100.00	10000.00
55	ROOF TOP RAIN WATER COLLECTION SYSTEM	SQ.M	100.00	100.00	10000.00
56	SEPTIC TANK	SQ.M	100.00	100.00	10000.00
57	RAINFALL	SQ.M	100.00	100.00	10000.00
58	STAIRS	SQ.M	100.00	100.00	10000.00
59	DOORS	SQ.M	100.00	100.00	10000.00
60	WINDOWS	SQ.M	100.00	100.00	10000.00
61	ROOF TOP RAIN WATER COLLECTION SYSTEM	SQ.M	100.00	100.00	10000.00
62	SEPTIC TANK	SQ.M	100.00	100.00	10000.00
63	RAINFALL	SQ.M	100.00	100.00	10000.00
64	STAIRS	SQ.M	100.00	100.00	10000.00
65	DOORS	SQ.M	100.00	100.00	10000.00
66	WINDOWS	SQ.M	100.00	100.00	10000.00
67	ROOF TOP RAIN WATER COLLECTION SYSTEM	SQ.M	100.00	100.00	10000.00
68	SEPTIC TANK	SQ.M	100.00	100.00	10000.00
69	RAINFALL	SQ.M	100.00	100.00	10000.00
70	STAIRS	SQ.M	100.00	100.00	10000.00
71	DOORS	SQ.M	100.00	100.00	10000.00
72	WINDOWS	SQ.M	100.00	100.00	10000.00
73	ROOF TOP RAIN WATER COLLECTION SYSTEM	SQ.M	100.00	100.00	10000.00
74	SEPTIC TANK	SQ.M	100.00	100.00	10000.00
75	RAINFALL	SQ.M	100.00	100.00	10000.00
76	STAIRS	SQ.M	100.00	100.00	10000.00
77	DOORS	SQ.M	100.00	100.00	10000.00
78	WINDOWS	SQ.M	100.00	100.00	10000.00
79	ROOF TOP RAIN WATER COLLECTION SYSTEM	SQ.M	100.00	100.00	10000.00
80	SEPTIC TANK	SQ.M	100.00	100.00	10000.00
81	RAINFALL	SQ.M	100.00	100.00	10000.00
82	STAIRS	SQ.M	100.00	100.00	10000.00
83	DOORS	SQ.M	100.00	100.00	10000.00
84	WINDOWS	SQ.M	100.00	100.00	10000.00
85	ROOF TOP RAIN WATER COLLECTION SYSTEM	SQ.M	100.00	100.00	10000.00
86	SEPTIC TANK	SQ.M	100.00	100.00	10000.00
87	RAINFALL	SQ.M	100.00	100.00	10000.00
88	STAIRS	SQ.M	100.00	100.00	10000.00
89	DOORS	SQ.M	100.00	100.00	10000.00
90	WINDOWS	SQ.M	100.00	100.00	10000.00
91	ROOF TOP RAIN WATER COLLECTION SYSTEM	SQ.M	100.00	100.00	10000.00
92	SEPTIC TANK	SQ.M	100.00	100.00	10000.00
93	RAINFALL	SQ.M	100.00	100.00	10000.00
94	STAIRS	SQ.M	100.00	100.00	10000.00
95	DOORS	SQ.M	100.00	100.00	10000.00
96	WINDOWS	SQ.M	100.00	100.00	10000.00
97	ROOF TOP RAIN WATER COLLECTION SYSTEM	SQ.M	100.00	100.00	10000.00
98	SEPTIC TANK	SQ.M	100.00	100.00	10000.00
99	RAINFALL	SQ.M	100.00	100.00	10000.00
100	STAIRS	SQ.M	100.00	100.00	10000.00
101	DOORS	SQ.M	100.00	100.00	10000.00
102	WINDOWS	SQ.M	100.00	100.00	10000.00
103	ROOF TOP RAIN WATER COLLECTION SYSTEM	SQ.M	100.00	100.00	10000.00
104	SEPTIC TANK	SQ.M	100.00	100.00	10000.00
105	RAINFALL	SQ.M	100.00	100.00	10000.00
106	STAIRS	SQ.M	100.00	100.00	10000.00
107	DOORS	SQ.M	100.00	100.00	10000.00
108	WINDOWS	SQ.M	100.00	100.00	10000.00
109	ROOF TOP RAIN WATER COLLECTION SYSTEM	SQ.M	100.00	100.00	10000.00
110	SEPTIC TANK	SQ.M	100.00	100.00	10000.00
111	RAINFALL	SQ.M	100.00	100.00	10000.00
112	STAIRS	SQ.M	100.00	100.00	10000.00
113	DOORS	SQ.M	100.00	100.00	10000.00
114	WINDOWS	SQ.M	100.00	100.00	10000.00
115	ROOF TOP RAIN WATER COLLECTION SYSTEM	SQ.M	100.00	100.00	10000.00
116	SEPTIC TANK	SQ.M	100.00	100.00	10000.00
117	RAINFALL	SQ.M	100.00	100.00	10000.00
118	STAIRS	SQ.M	100.00	100.00	10000.00
119	DOORS	SQ.M	100.00	100.00	10000.00
120	WINDOWS	SQ.M	100.00	100.00	10000.00
121	ROOF TOP RAIN WATER COLLECTION SYSTEM	SQ.M	100.00	100.00	10000.00
122	SEPTIC TANK	SQ.M	100.00	100.00	10000.00
123	RAINFALL	SQ.M	100.00	100.00	10000.00
124	STAIRS	SQ.M	100.00	100.00	10000.00
125	DOORS	SQ.M	100.00	100.00	10000.00
126	WINDOWS	SQ.M	100.00	100.00	10000.00
127	ROOF TOP RAIN WATER COLLECTION SYSTEM	SQ.M	100.00	100.00	10000.00
128	SEPTIC TANK	SQ.M	100.00	100.00	10000.00
129	RAINFALL	SQ.M	100.00	100.00	10000.00
130	STAIRS	SQ.M	100.00	100.00	10000.00
131	DOORS	S			