

Proposal Basic Information	
Proposal File No.	DMC/BP/0273/W23/2024
Owner Name	DHIRAJ KUMAR SINGH
Khata No	2(OLD), 7(NEW)
Plot No	86(OLD), 157(NEW)
Village Name	Amaghata
Use	Residential
SubUse	Bungalow/ Dwelling / Non Apartment

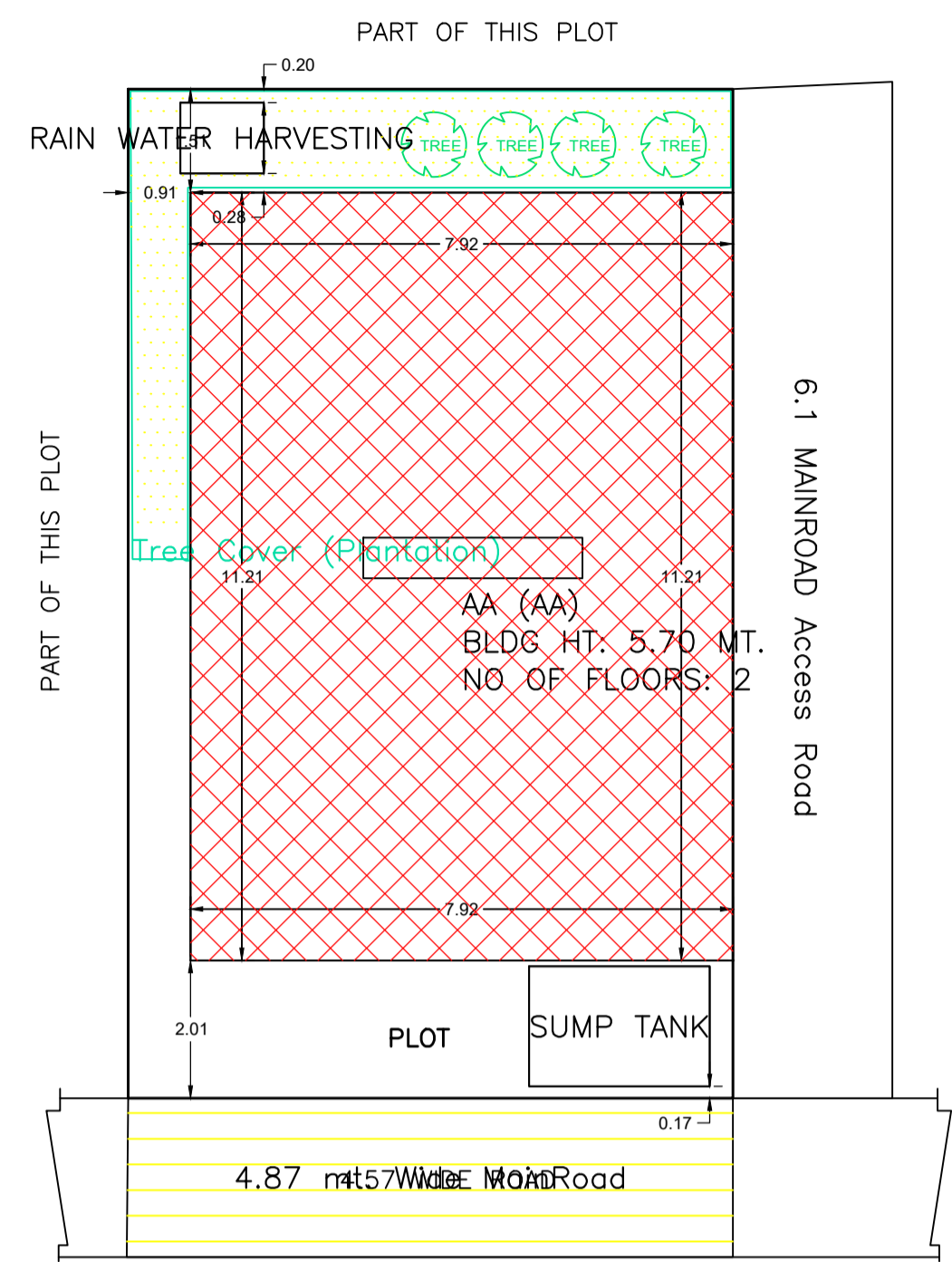

SITE PLAN

SITE PLAN

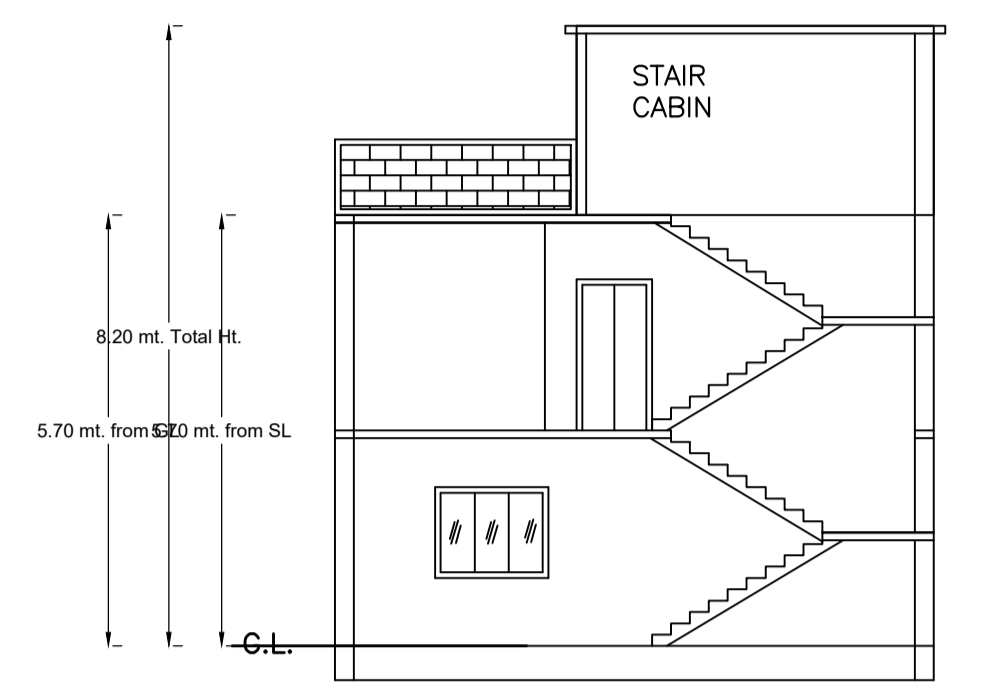

SECTION ON X-X

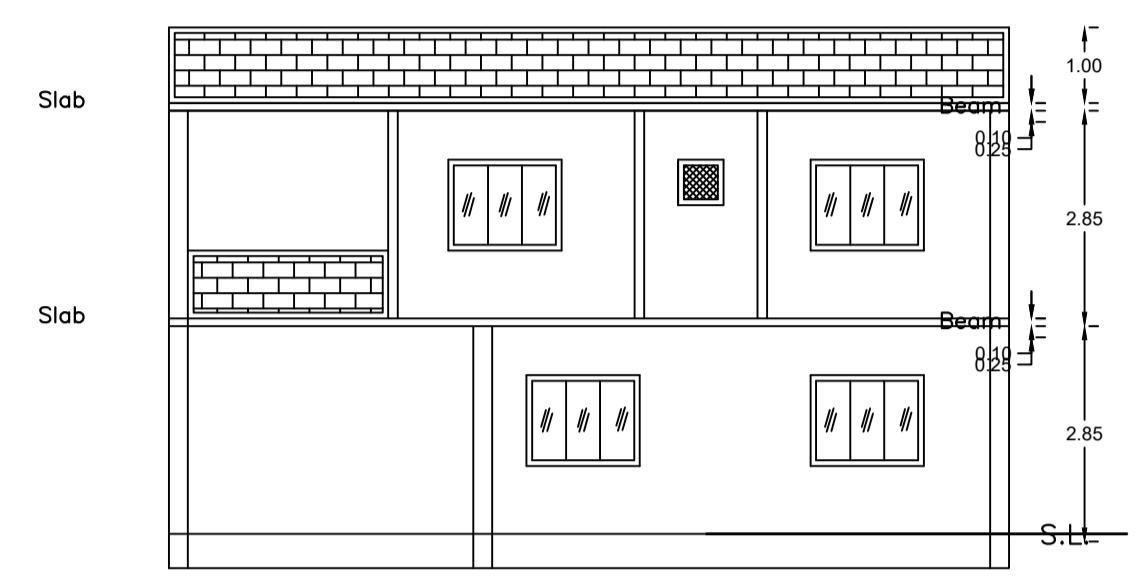

SECTION ON Y-Y

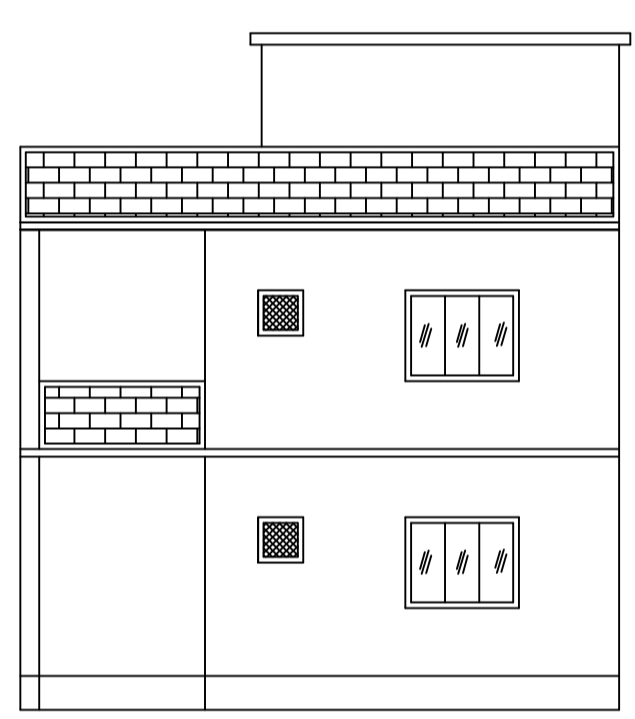

FRONT ELEVATION

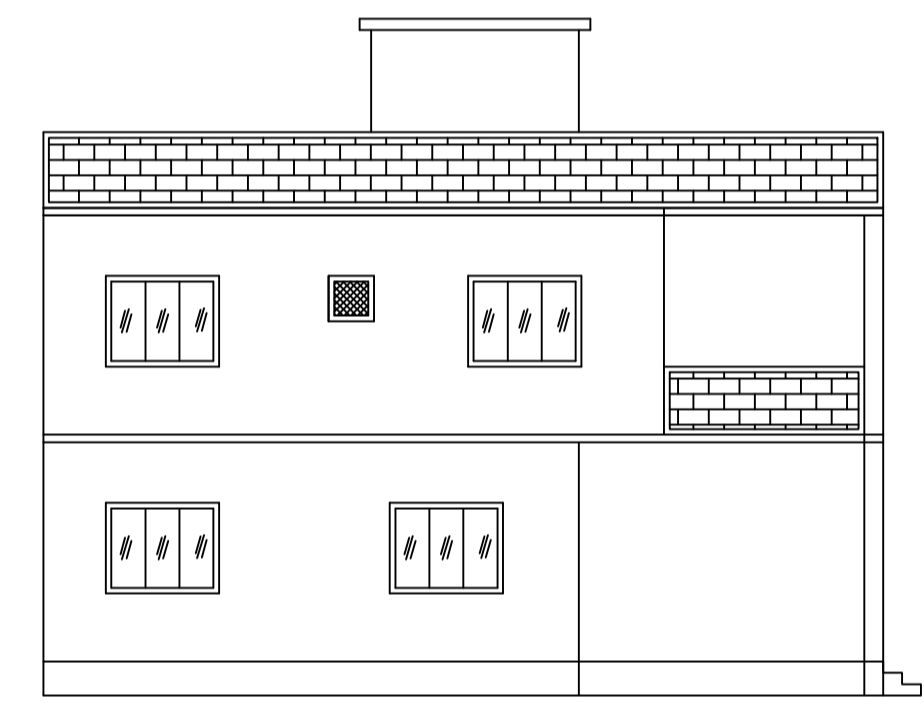

LEFT SIDE ELEVATION

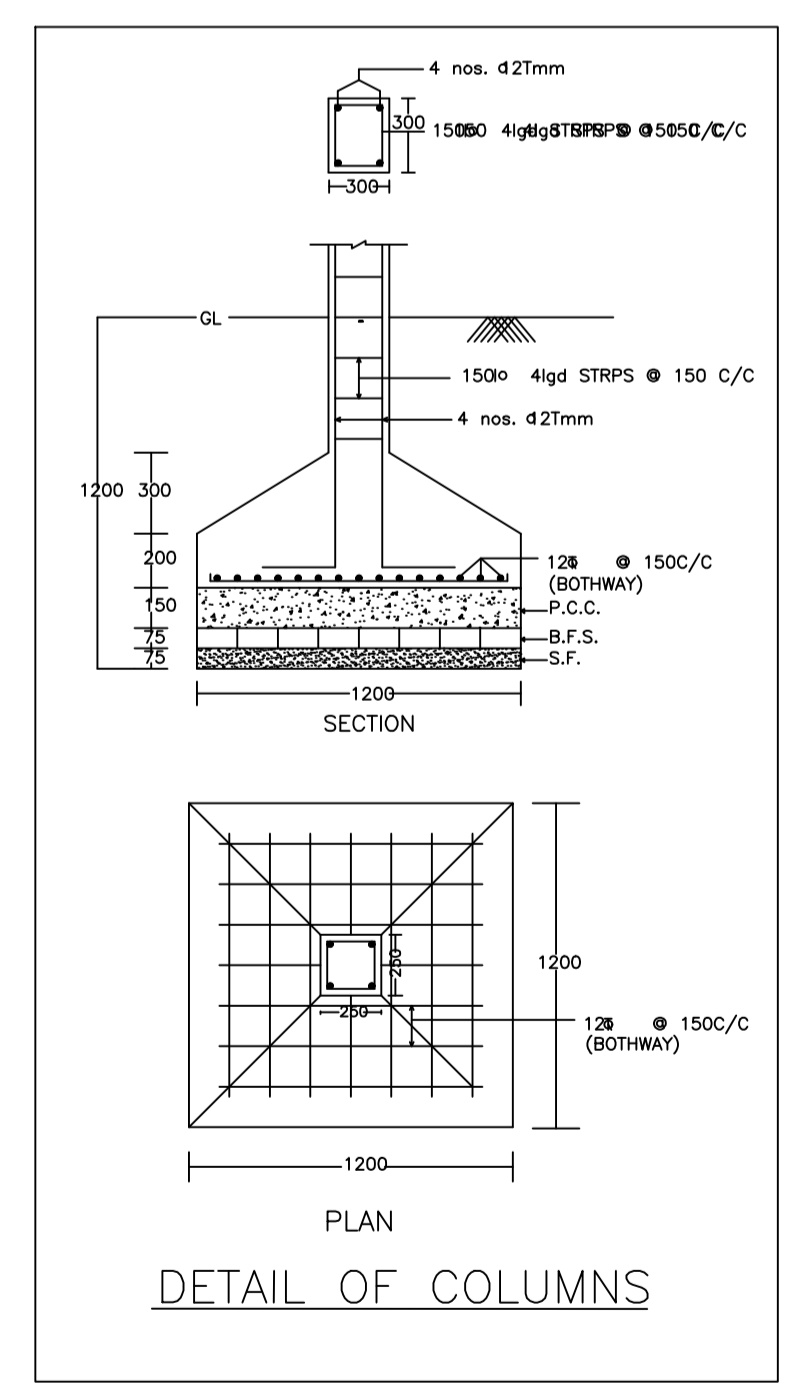

DETAIL OF COLUMNS

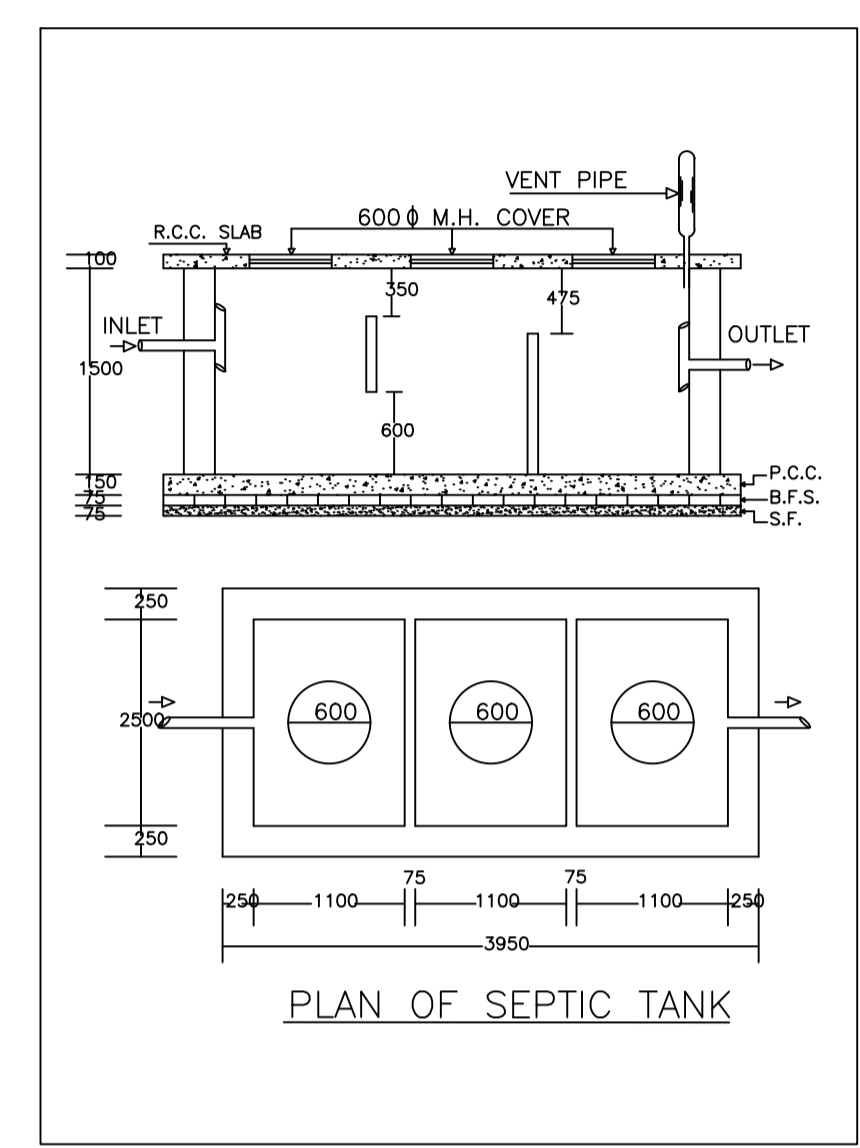
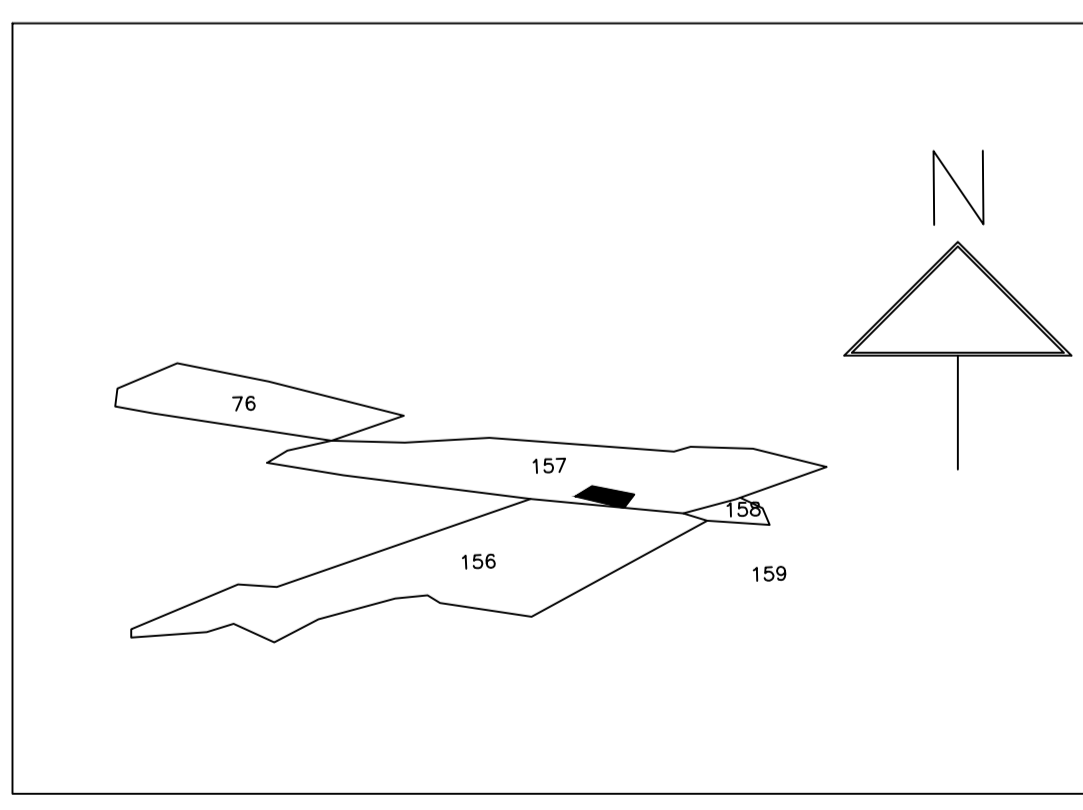

PLAN OF SEPTIC TANK

AREA STATEMENT		VERSION NO. : 1.0.73
DHANBAD MUNICIPAL CORPORATION		VERSION DATE: 16/10/2020
PROJECT DETAIL:		
Region: JHARKHAND URBAN LOCAL BODIES	Plot Use: Residential	
District: DHANBAD CORPORATION	Plot SubUse: Bungalow/ Dwelling / Non Apartment	
Authority: DHANBAD MUNICIPAL CORPORATION	PlotNearby/ReligiousStructure: NA	
Inward No: DMC/BP/0273/W23/2024	Plot/SubPlot No: 86(OLD), 157(NEW)	
Application Type: General Proposal	North: Plot No. - PART OF THIS PLOT	
Project Type: Building Permission	South: Road Width - 6.10 WIDE ROAD	
Nature of Development: New	East: Plot No. - PART OF THIS PLOT	
Location of Development Area: Old Area	West: Road Width - 4.57 WIDE ROAD	
AREA DETAILS:		
AREA OF PLOT (Minimum)	(A)	SQ.MT. 130.07
NET AREA OF PLOT(Gross Plot Area - Deduction from Gross Plot area)	(A-Deductions)	130.07
Deduction for Balance Plot Area(from Gross Plot Area)		
Common Plot		16.82
Total		16.82
BALANCE AREA OF PLOT(Net Plot Area - Recreational/Amenity space)	(A-Deductions)	113.24
PLOT AREA FOR COVERAGE(Net Plot Area)	(A-Deductions)	130.07
Plot Area for FAR (Net Plot Area + Road Widening Area)	(A-Deductions)	130.07
COVERAGE CHECK		
Permissible Coverage area ( 70.00 % )		91.05
Proposed Coverage Area ( 68.26 % )		88.78
Total Prop. Coverage Area ( 68.26 % )		88.78
Balance coverage area ( 1.75 % )		2.27
FAR CHECK		
Perm. FAR Area ( 1.800 )		234.13
Total Perm. FAR area		234.13
Residential FAR		177.57
Proposed FAR Area		177.57
Total Proposed FAR Area		177.57
Consumed FAR (Factor)		1.37
Balance FAR Area		56.56
BUILT UP AREA CHECK		
Total Proposed BuiltUp Area		177.56
ARCHITECT (Regd)	ASHOK KUMAR	
ENGINEER (Regd)		
SUPERVISOR (Regd)		
OWNER (Regd)	DHIRAJ KUMAR SINGH	
DEVELOPMENT AUTHORITY LOCAL BODY		

COLOR INDEX	
PLOT BOUNDARY	Black
ABUTTING ROAD	Green
PROPOSED CONSTRUCTION	Red
COMMON PLOT	Yellow
ROAD WIDENING AREA	Blue
EXISTING (To be retained)	Orange
EXISTING (To be demolished)	Light Blue

Floor Name	Building Name		Total	
	Proposed Built Up Area (Sq.mt.)	Proposed FAR Area (Sq.mt.)	Total Proposed Built Up Area (Sq.mt.)	Total FAR Area (Sq.mt.)
Ground Floor	88.78	88.78	88.78	88.78
First Floor	88.78	88.78	88.78	88.78
Terrace Floor	0.00	0.00	0.00	0.00
Total :	177.56	177.56	177.56	177.56

UnitBUA Table for Building :AA (AA)

FLOOR	Name	UnitBUA Type	UnitBUA Area	Carpet Area	No. of Rooms	No. of Tenement
GROUND FLOOR	SPLIT AA	FLAT	177.57	177.07	6	1
FIRST FLOOR	SPLIT AA	FLAT	0.00	0.00	7	0
Total:	-	-	177.57	177.07	13	1

SCHEDULE OF DOOR:

BUILDING NAME	NAME	LENGTH	HEIGHT	NOS
AA (AA)	D3	0.90	2.10	04
AA (AA)	D2	0.90	2.10	01
AA (AA)	D1	0.96	2.10	01
AA (AA)	D1	1.00	2.10	03
AA (AA)	D1	1.01	2.10	01
AA (AA)	D	1.50	2.10	01

SCHEDULE OF WINDOW/VENTILATION:

BUILDING NAME	NAME	LENGTH	HEIGHT	NOS
AA (AA)	V	0.60	1.20	03
AA (AA)	W1	1.20	1.20	01
AA (AA)	W2	1.22	1.20	01
AA (AA)	W	1.80	1.20	10

Building :AA (AA)

Floor Name	Total Built Up Area (Sq.mt.)	Proposed FAR Area (Sq.mt.)	Total FAR Area (Sq.mt.)	Total Consumed Additional FAR Area (Sq.mt.)	Trnmt (No.)
Ground Floor	88.78	88.78	88.78	88.78	01
First Floor	88.78	88.78	88.78	88.78	00
Terrace Floor	0.00	0.00	0.00	0.00	00
Total:	177.56	177.56	177.56	177.56	01
Total Number of Same Buildings :	1				
Total :	177.56	177.56	177.56	177.56	01

Building USE/SUBUSE Details

Building Name	Building Use	Building SubUse	Building Structure	Floor Name	Floor Use	Floor SubUse	FAR Name	FAR Use	FAR SubUse
AA (AA)	Residential	Bungalow/ Dwelling / Non Apartment	Non-Highrise	GROUND FLOOR PLAN	Residential	Bungalow/ Dwelling / Non Apartment	Residential FAR	Residential	Bungalow/ Dwelling / Non Apartment
				FIRST FLOOR PLAN	Residential	Bungalow/ Dwelling / Non Apartment	Residential FAR	Residential	Bungalow/ Dwelling / Non Apartment
				TERRACE FLOOR PLAN	Residential	Bungalow/ Dwelling / Non Apartment	-	-	-

FAR & Tenement Details (Table 4c-1)

Building	No. of Same Bldg	Total Built Up Area (Sq.mt.)	Proposed FAR Area (Sq.mt.)	Total FAR Area (Sq.mt.)	Total Consumed Additional FAR Area (Sq.mt.)	Trnmt (No.)
AA (AA)	1	177.56	177.56	177.56	177.56	01
Grand Total :	1	177.56	177.56	177.56	177.56	01

LTP NAME AND SIGNATURE STRUCTURAL ENG'S NAME AND SIGNATURE BUILDER NAME AND SIGNATURE DIGITAL SIGNATURE

ASHOK KUMAR DMC/ENG/0011/2017			
----------------------------------	--	--	--

Proposal Basic Information	
Proposal File No.	DMC/BP/0273/W23/2024
Owner Name	DHIRAJ KUMAR SINGH
Khata No	2(OLD), 7(NEW)
Plot No	86(OLD), 157(NEW)
Village Name	Amaghata
Use	Residential
SubUse	Bungalow/ Dwelling / Non Apartment

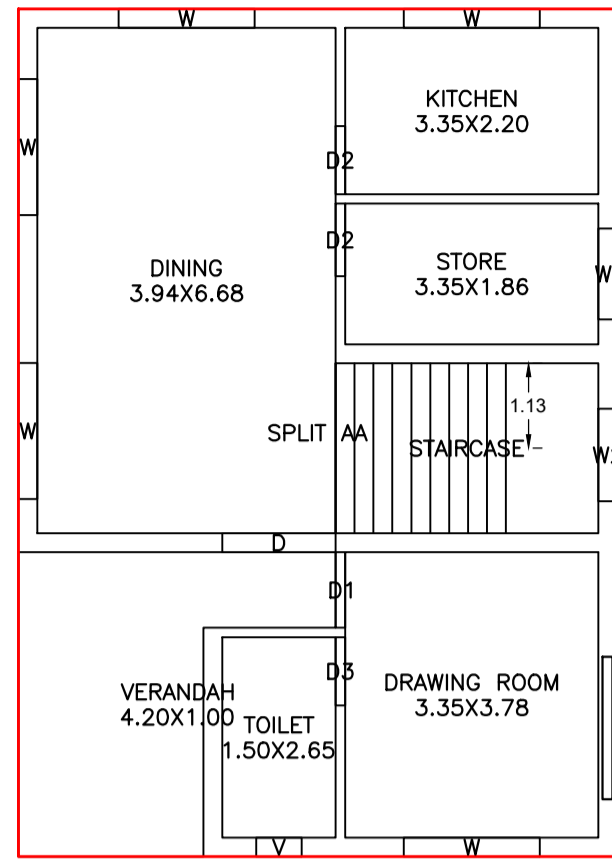

GROUND FLOOR PLAN  
(Proposed)  
(SCALE 1:100)

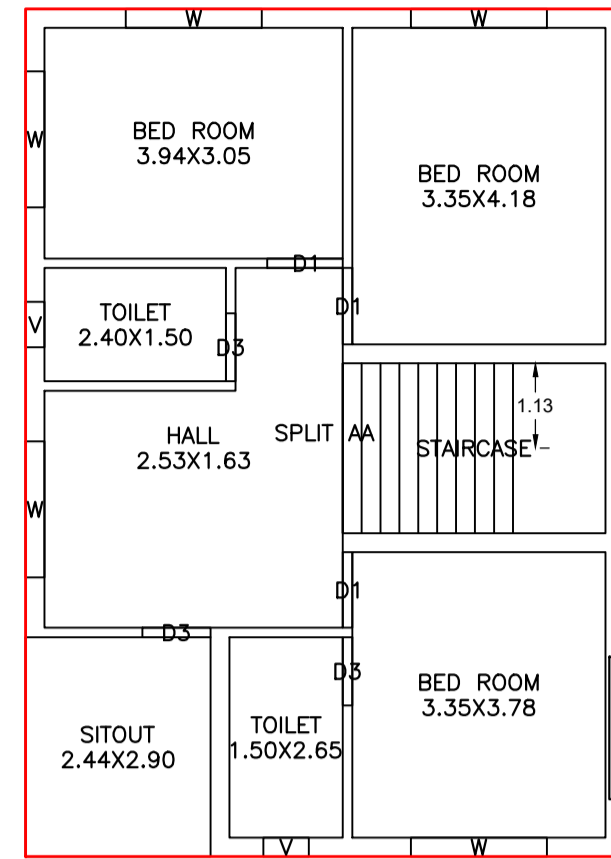

FIRST FLOOR PLAN  
(Proposed)  
(SCALE 1:100)

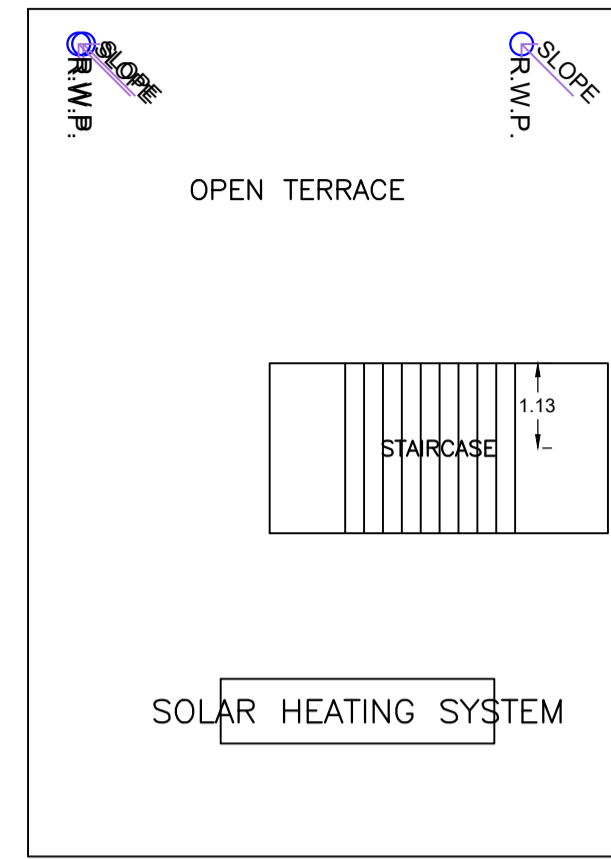

TERRACE FLOOR PLAN  
(SCALE 1:100)

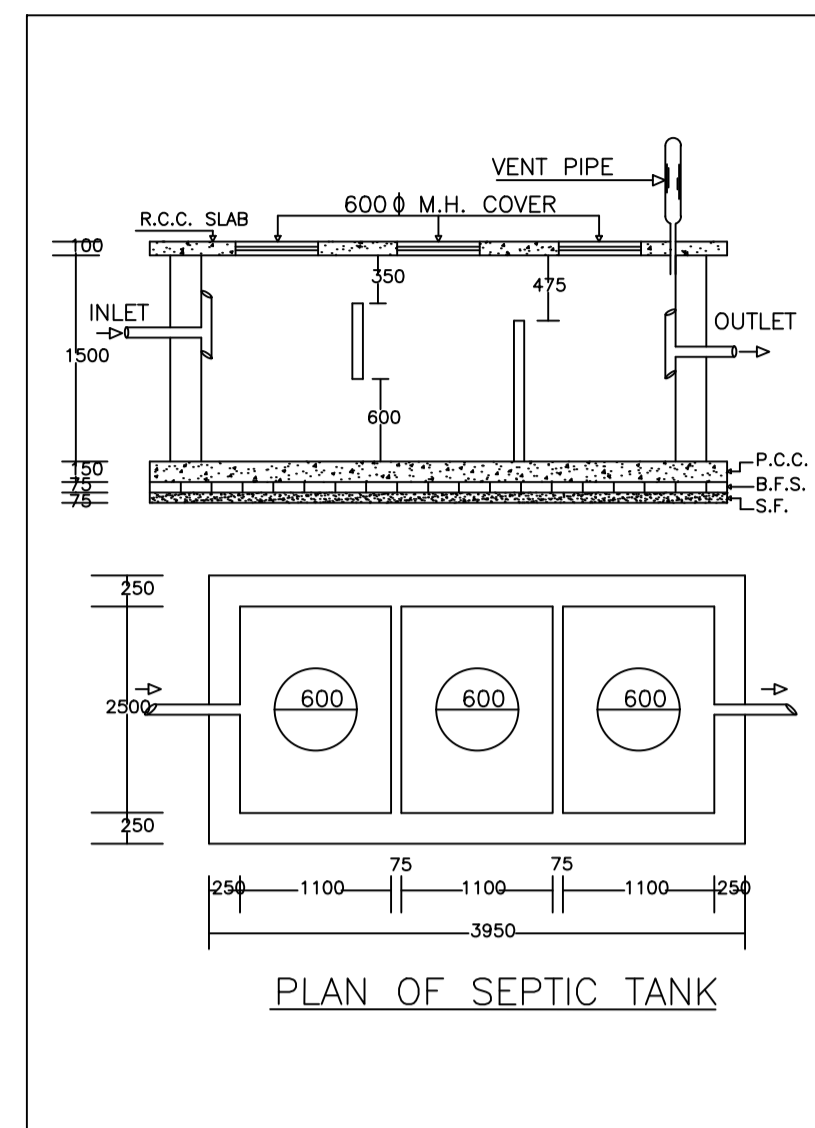

PLAN OF SEPTIC TANK

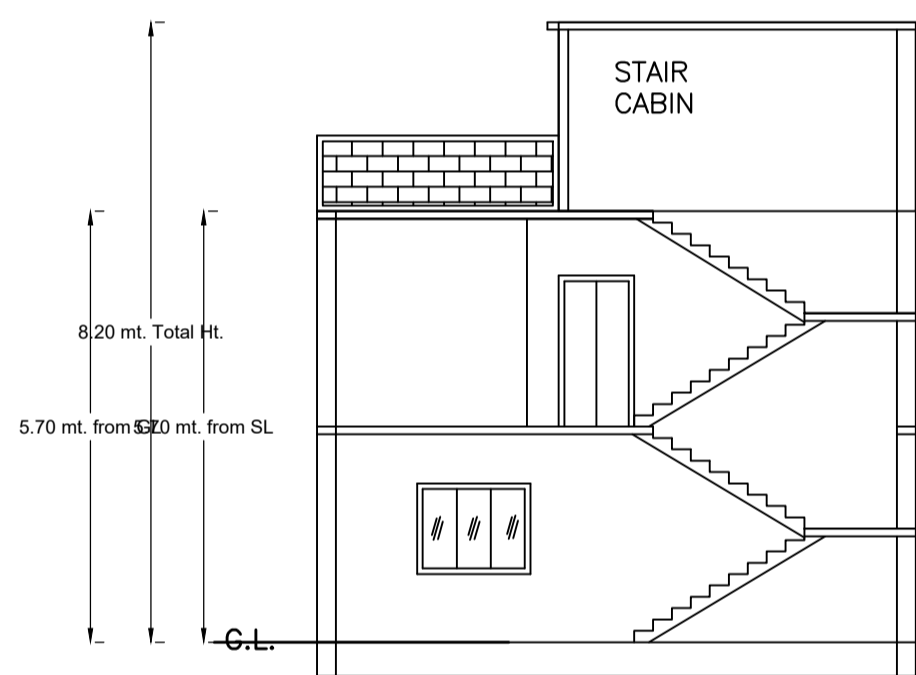
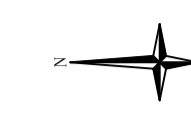
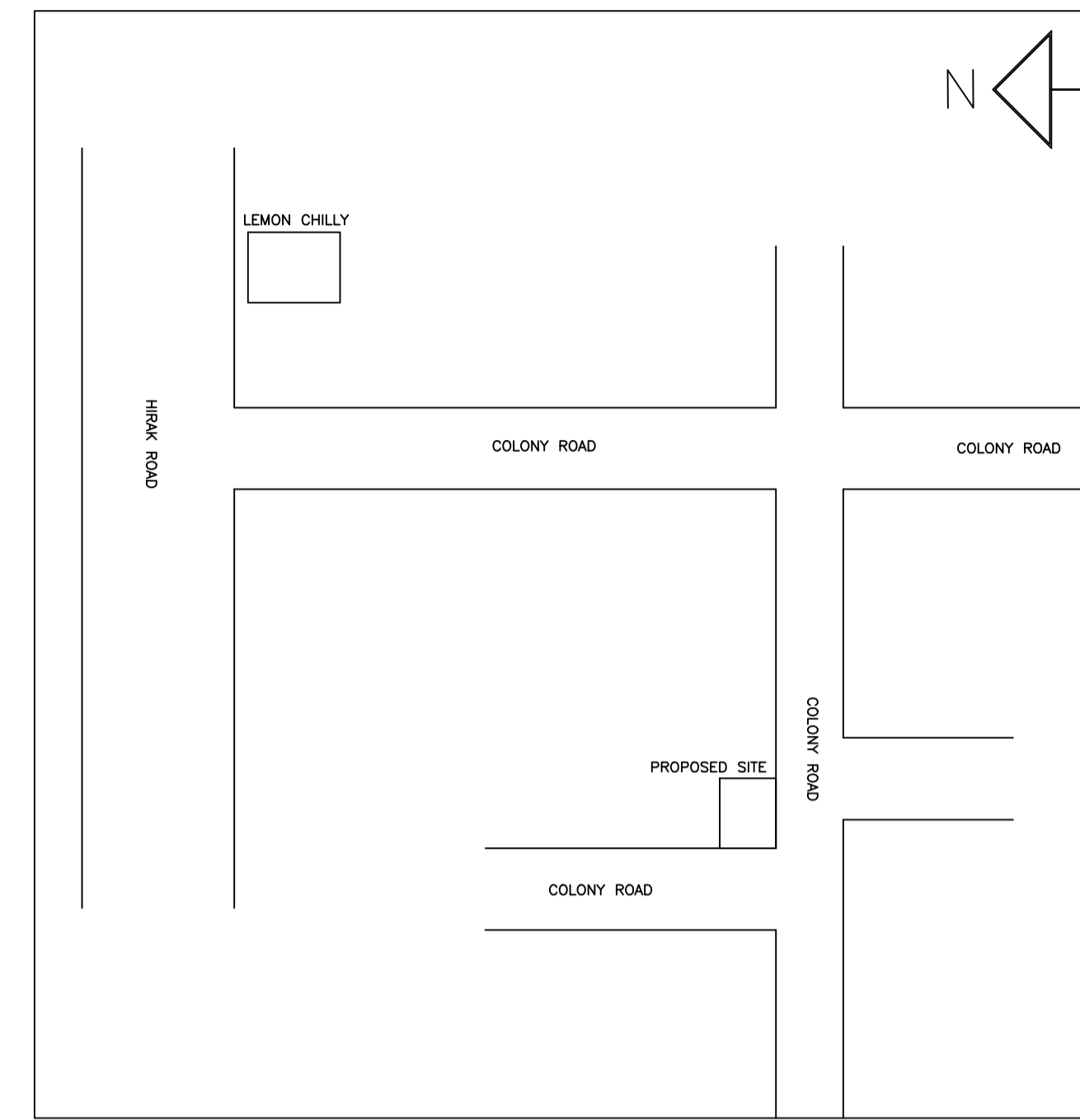

SECTION ON X-X

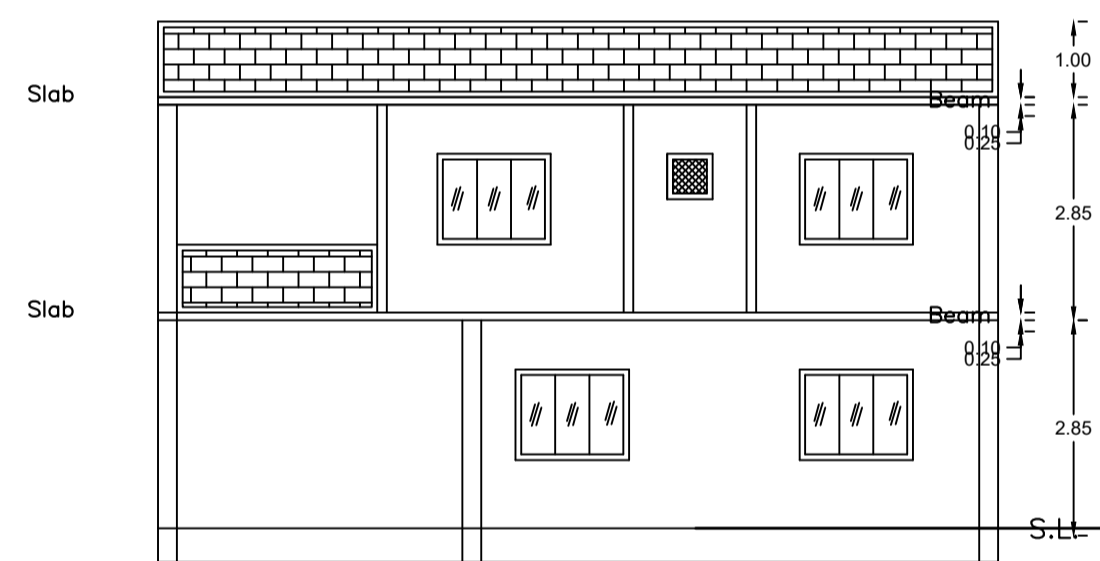

SECTION ON Y-Y

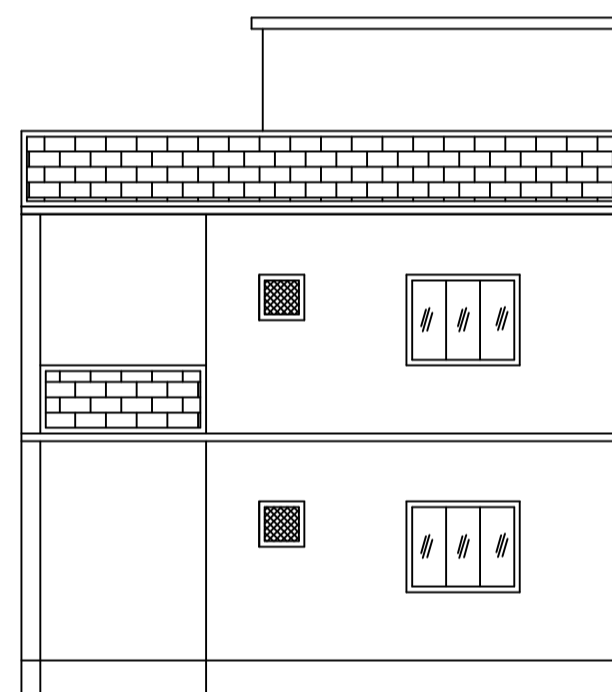

FRONT ELEVATION

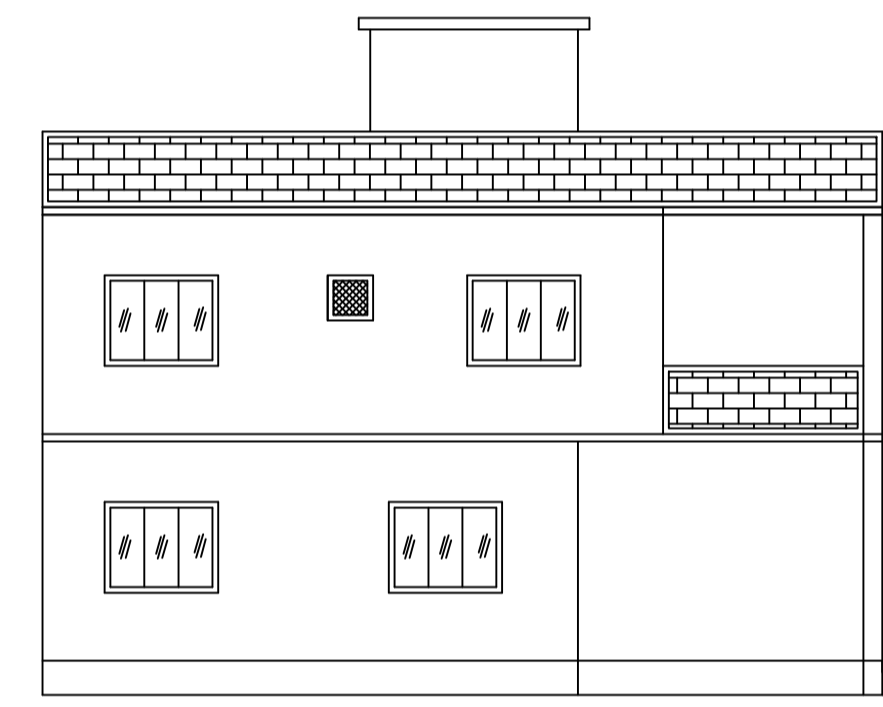

LEFT SIDE ELEVATION

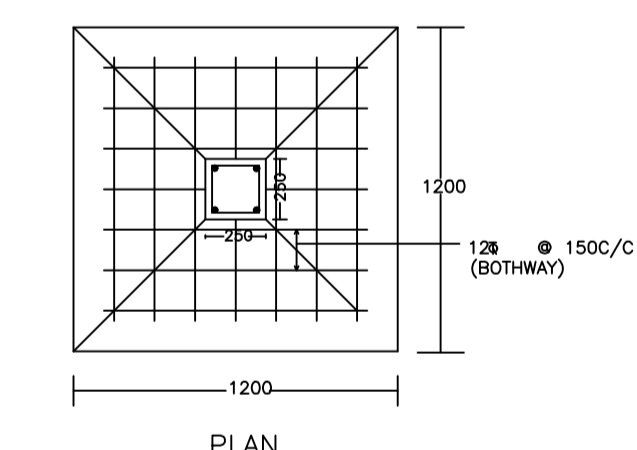
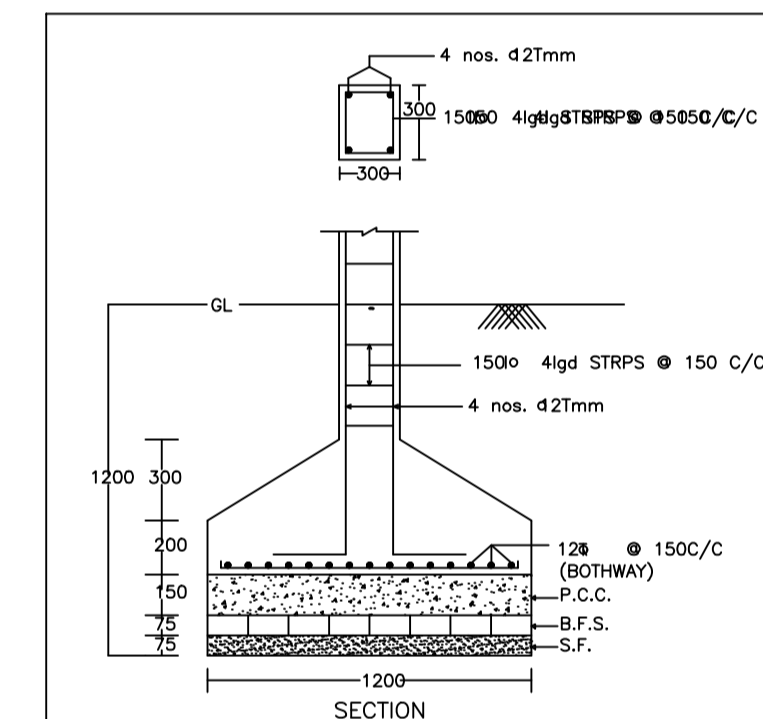

DETAIL OF COLUMNS

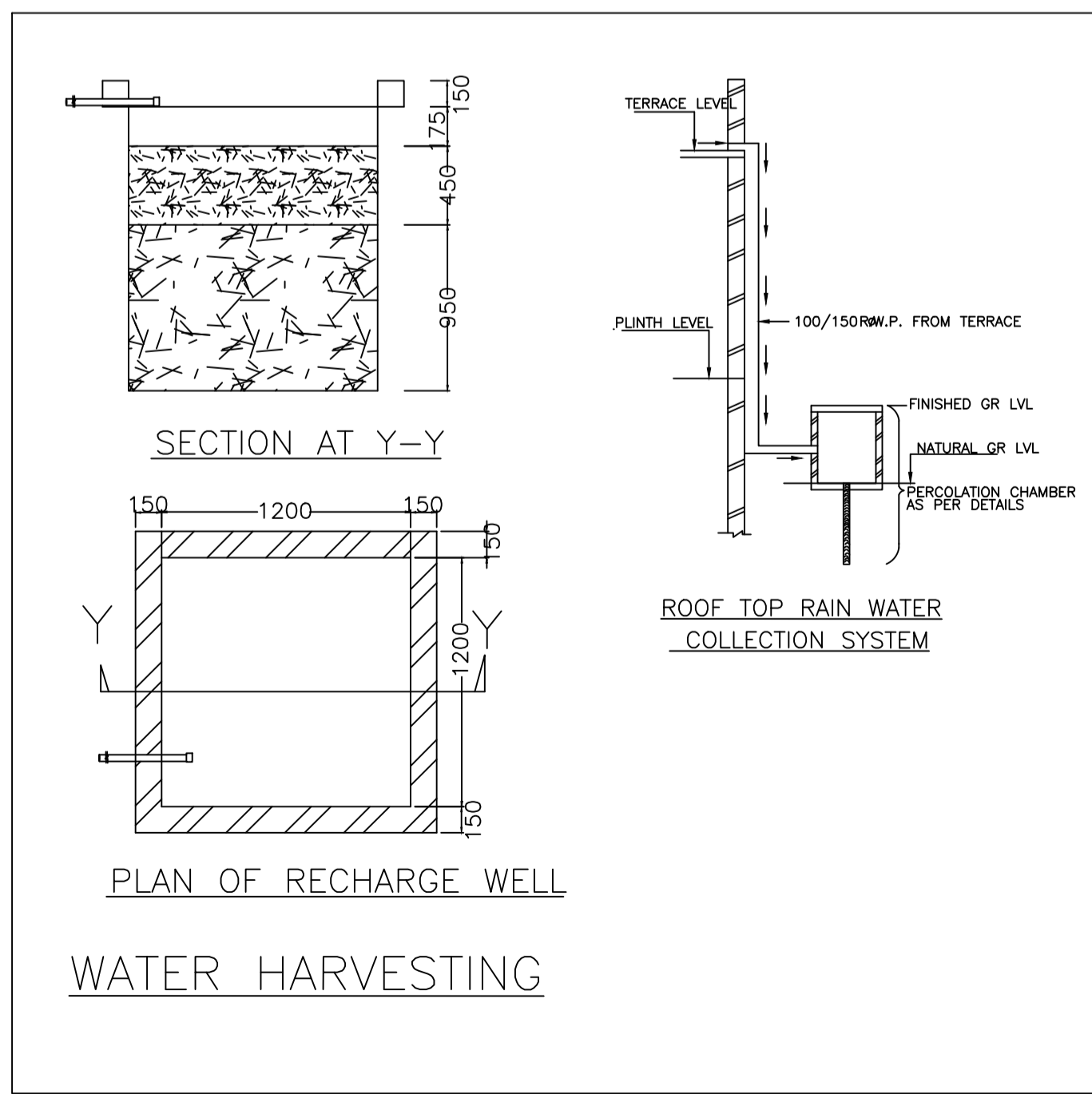

WATER HARVESTING

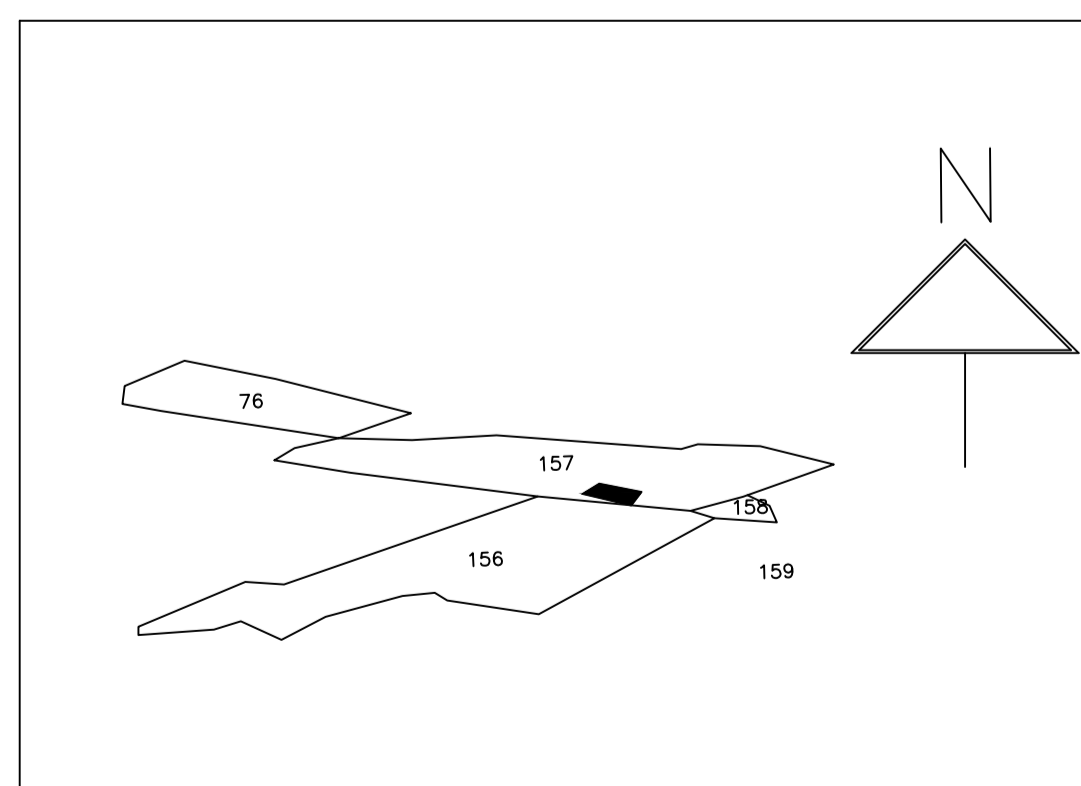

LTP NAME AND SIGNATURE	STRUCTURAL ENG'S NAME AND SIGNATURE	BUILDER NAME AND SIGNATURE	DIGITAL SIGNATURE
ASHOK KUMAR DMC/ENG/001/2017			