

FAR & Tenement Details (Table 4c-1)

Building	No. of Same Bldg	Gross Built Up Area (Sq.mt.)	Deductions From Gross BUA(Area in Sq.mt.)	Total Built Up Area (Sq.mt.)	Deductions (Area in Sq.mt.)				Proposed FAR Area (Sq.mt.)	Add Area In FAR (Sq.mt.)	Total FAR Area (Sq.mt.)	Total Consumed Additional FAR Area (Sq.mt.)	Trmt (No.)
					StairCase	Lift	Lift Machine	Parking					
A (BUILDING)	1	8866.90	524.57	8342.33	79.74	75.89	4.60	884.05	7177.98	46.07	7224.06	7224.06	43
Grand Total	1	8866.90	524.57	8342.33	79.74	75.89	4.60	884.05	7177.98	46.07	7224.06	7224.06	43

Building :A (BUILDING)

Floor Name	Gross Built Up Area	Deductions From Gross BUA(Area in Sq.mt.)	Total Built Up Area (Sq.mt.)	Deductions (Area in Sq.mt.)				Proposed FAR Area (Sq.mt.)	Add Area In FAR (Sq.mt.)	Total FAR Area (Sq.mt.)	Total Consumed Additional FAR Area (Sq.mt.)	Trmt (No.)
				StairCase	Lift	Lift Machine	Parking					
Basement Floor	989.60	0.00	989.60	0.00	9.53	0.00	884.05	0.00	22.03	22.03	22.03	00
Ground Floor	1519.89	0.00	1519.89	13.29	0.00	0.00	1506.60	0.00	1506.60	1506.60	1506.60	09
First Floor	1568.86	524.57	1044.29	13.29	14.12	0.00	1016.88	0.00	1016.88	1016.88	1016.88	06
Second Floor	1232.11	0.00	1232.11	13.29	14.12	0.00	1204.70	0.00	1204.70	1204.70	1204.70	08
Third Floor	910.59	0.00	910.59	13.29	9.53	4.60	859.13	24.04	883.17	883.17	883.17	05
Fourth Floor	881.95	0.00	881.95	13.29	9.53	0.00	859.13	0.00	859.13	859.13	859.13	05
Fifth Floor	881.95	0.00	881.95	0.00	9.53	0.00	872.42	0.00	872.42	872.42	872.42	05
Sixth Floor	881.95	0.00	881.95	13.29	9.53	0.00	859.13	0.00	859.13	859.13	859.13	05
Terrace Floor	0.00	0.00	0.00	0.00	0.00	0.00	0.00	0.00	0.00	0.00	0.00	00
Total	8866.90	524.57	8342.33	79.74	75.89	4.60	884.05	7177.98	46.07	7224.06	7224.06	43

Proposal Basic Information

Proposal File No.	JIADA/BP/0017/2019
Owner Name	N.R INTERNATIONAL LTD THROUGH ITS DIRECTOR NIRMAL MODI
Khata No	96,54
Plot No	55p, 52p, 53p
Village Name	Tugru
Use	Commercial
SubUse	Commercial Bldg

AREA STATEMENT	VERSION NO. : 1.0.43
JHARKHAND INDUSTRIAL AREA DEVELOPMENT AUTHORITY	VERSION DATE: 29/04/2019
PROJECT DETAIL:	
Region: JHARKHAND URBAN LOCAL BODIES	Plot Use: Commercial
District: RANCHI	Plot SubUse: Commercial Bldg
Authority: JHARKHAND INDUSTRIAL AREA DEVELOPMENT AUTHORITY	PlotNearby/ReligiousStructure: NA
Inward No: JIADA/BP/0017/2019	Plot/SubPlot No: 55p, 52p, 53p
Application Type: General Proposal	North: -
Project Type: Building Permission	South: -
Nature of Development: New	East: -
Location of Development Area: New Area	West: -

AREA DETAILS:		SQ.MT.
AREA OF PLOT (Minimum)	(A)	3149.58
NET AREA OF PLOT(Gross Plot Area - Deduction from Gross Plot area)	(A-Deductions)	3149.58
Deduction for Balance Plot Area(from Gross Plot Area)		
Common Plot		324.45
Total		324.45
BALANCE AREA OF PLOT(Net Plot Area - Recreational/Amenity space)	(A-Deductions)	2825.13
PLOT AREA FOR COVERAGE(Net Plot Area)	(A-Deductions)	3149.58
Plot Area for FAR Net Plot Area + Road/Widening Area)	(A-Deductions)	3149.58
COVERAGE CHECK		
Permissible Coverage area (50.00 %)		1574.79
Proposed Coverage Area (47.83 %)		1506.60
Total Prop. Coverage Area (47.83 %)		1506.60
Balance coverage area (2.17 %)		68.19
FAR CHECK		
Perm. FAR Area (3.00)		9448.74
Total Perm. FAR Area		9448.74
Commercial FAR		7177.98
Proposed FAR Area		7224.05
Total Proposed FAR Area		7224.05
Consumed FAR (Factor)		2.29
Balance FAR Area		2224.69
BUILT UP AREA CHECK		
Total Proposed BuiltUp Area		8342.33
ARCHITECT (Regd)	RAJIV CHADDA	
ENGINEER (Regd)		
SUPERVISOR (Regd)		
OWNER (Regd)	N.R INTERNATIONAL LTD THROUGH ITS DIRECTOR NIRMAL MODI	
DEVELOPMENT AUTHORITY LOCAL BODY		

Buildingwise Floor FAR Details

Floor Name	Building Name A (BUILDING)		Total	
	Proposed Built Up Area (Sq.mt.)	Proposed FAR Area (Sq.mt.)	Total Proposed Built Up Area (Sq.mt.)	Total FAR Area (Sq.mt.)
Basement Floor	989.60	22.03	989.60	22.03
Ground Floor	1519.89	1506.60	1519.89	1506.60
First Floor	1044.29	1016.88	1044.29	1016.88
Second Floor	1232.11	1204.70	1232.11	1204.70
Third Floor	910.59	883.17	910.59	883.17
Fourth Floor	881.95	859.13	881.95	859.13
Fifth Floor	881.95	872.42	881.95	872.42
Sixth Floor	881.95	859.13	881.95	859.13
Terrace Floor	0.00	0.00	0.00	0.00
Total	8342.33	7224.06	8342.33	7224.06

SCHEDULE OF DOOR:

BUILDING NAME	NAME	LENGTH	HEIGHT	NOS
A (BUILDING)	D2	0.75	2.10	42
A (BUILDING)	D2	0.90	2.10	12
A (BUILDING)	D	0.90	2.10	06
A (BUILDING)	D	1.00	2.10	06
A (BUILDING)	D	1.50	2.10	01
A (BUILDING)	RS	2.00	2.10	03
A (BUILDING)	RS	2.00	2.10	03
A (BUILDING)	FD	3.00	2.10	24
A (BUILDING)	FD	3.00	2.10	01

SCHEDULE OF WINDOW/VENTILATION:

BUILDING NAME	NAME	LENGTH	HEIGHT	NOS
A (BUILDING)	V	0.75	0.80	32
A (BUILDING)	W	1.20	1.20	08
A (BUILDING)	W	1.80	1.20	98

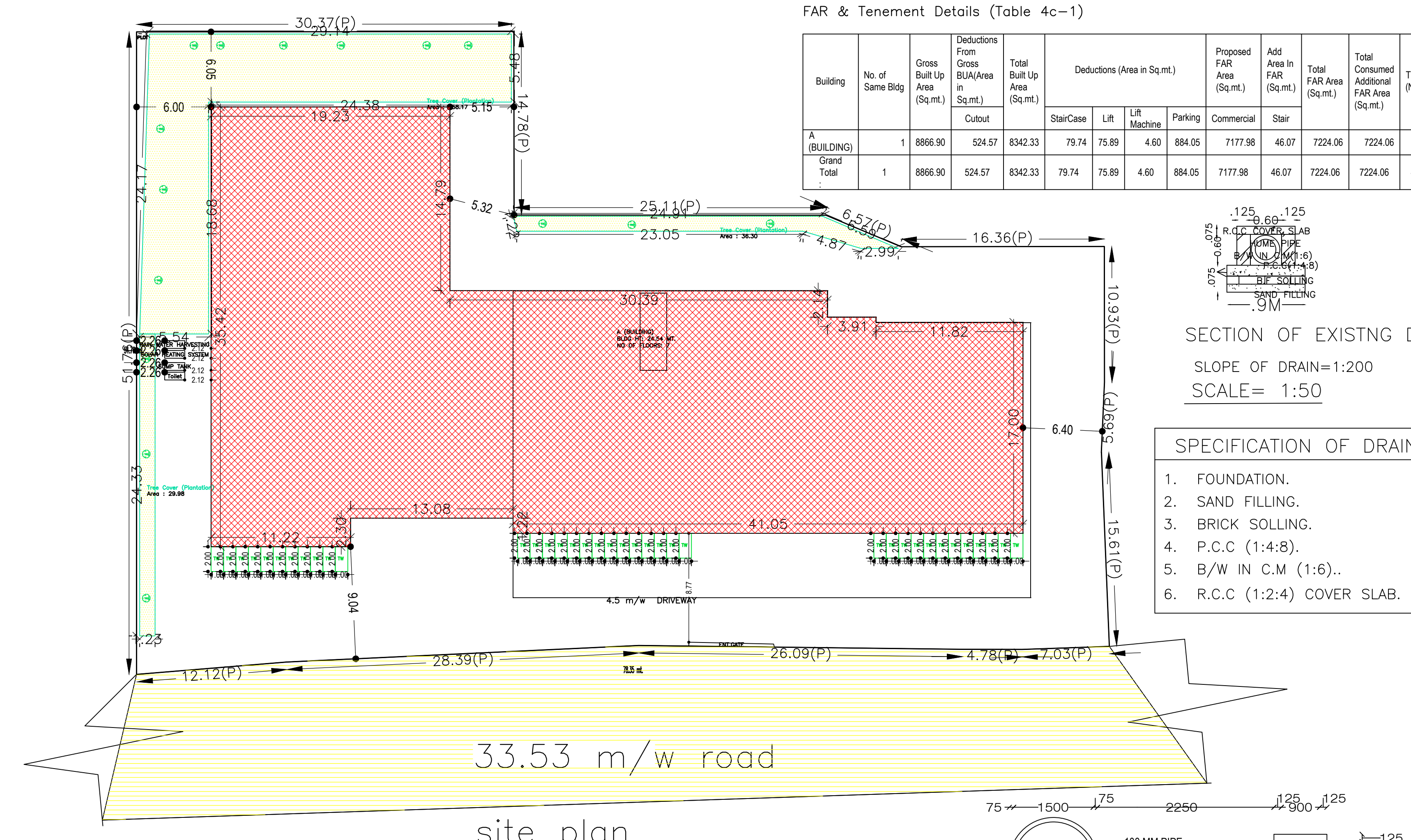

SECTION OF EXISTING DRAIN
SLOPE OF DRAIN=1:200
SCALE= 1:50

- SPECIFICATION OF DRAIN
- FOUNDATION.
 - SAND FILLING.
 - BRICK SOLLING.
 - P.C.C (1:4:8).
 - B/W IN C.M (1:6)..
 - R.C.C (1:2:4) COVER SLAB.

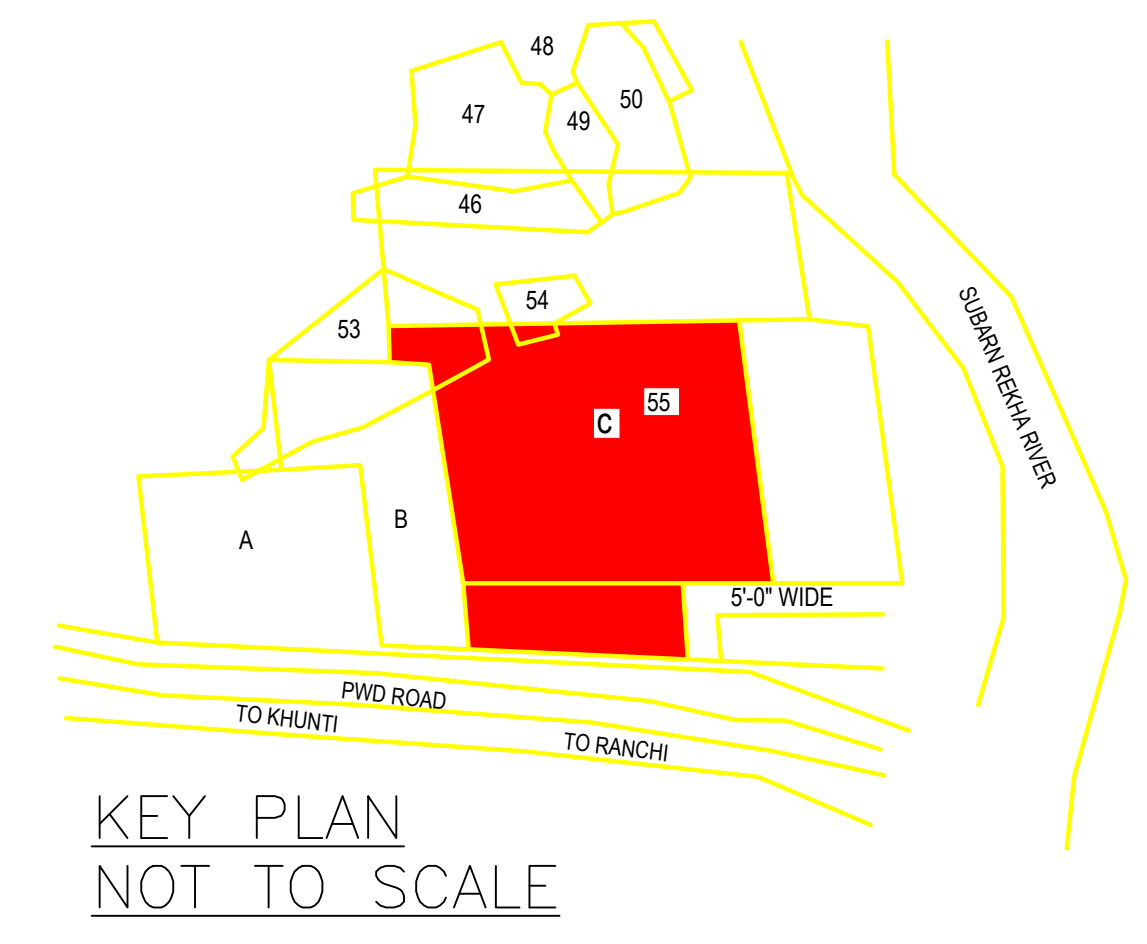
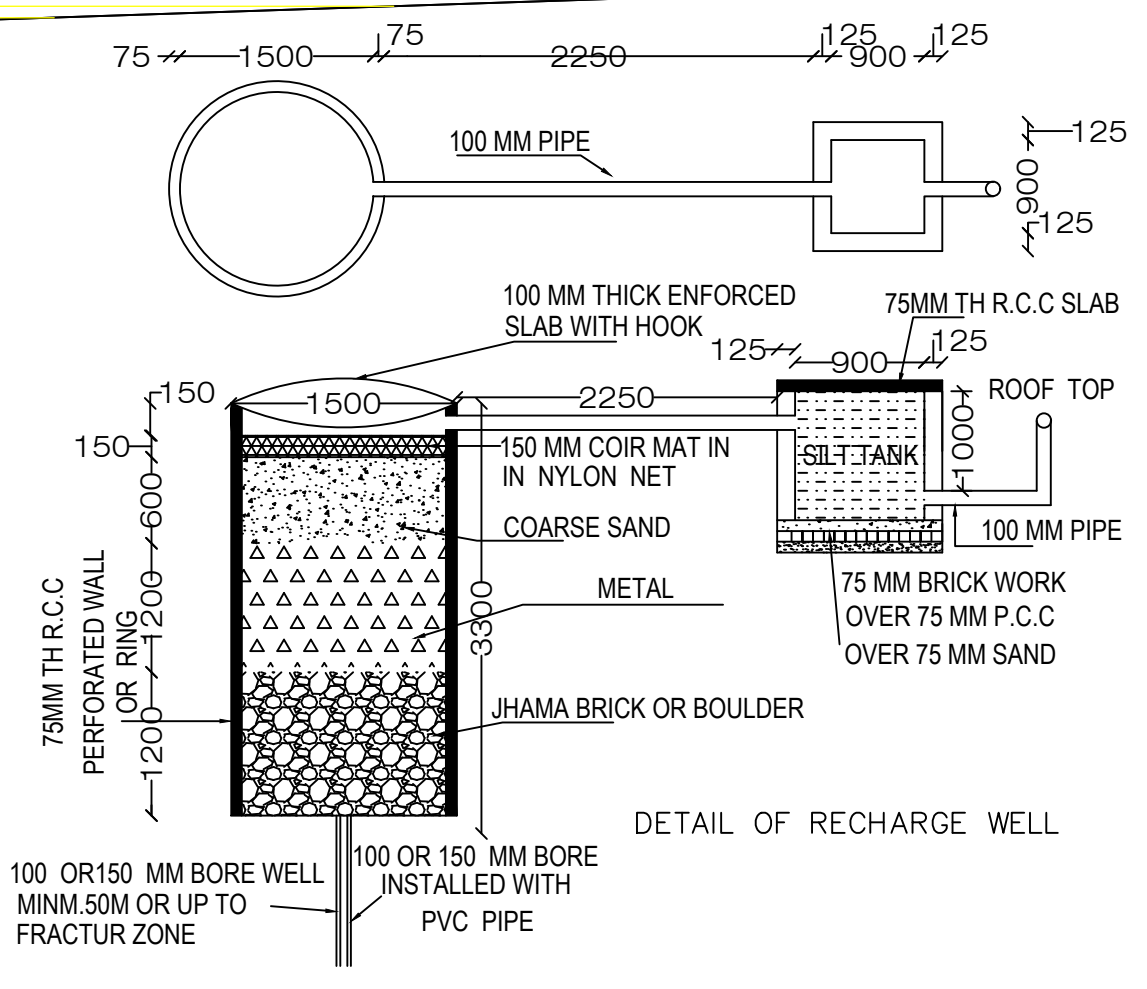
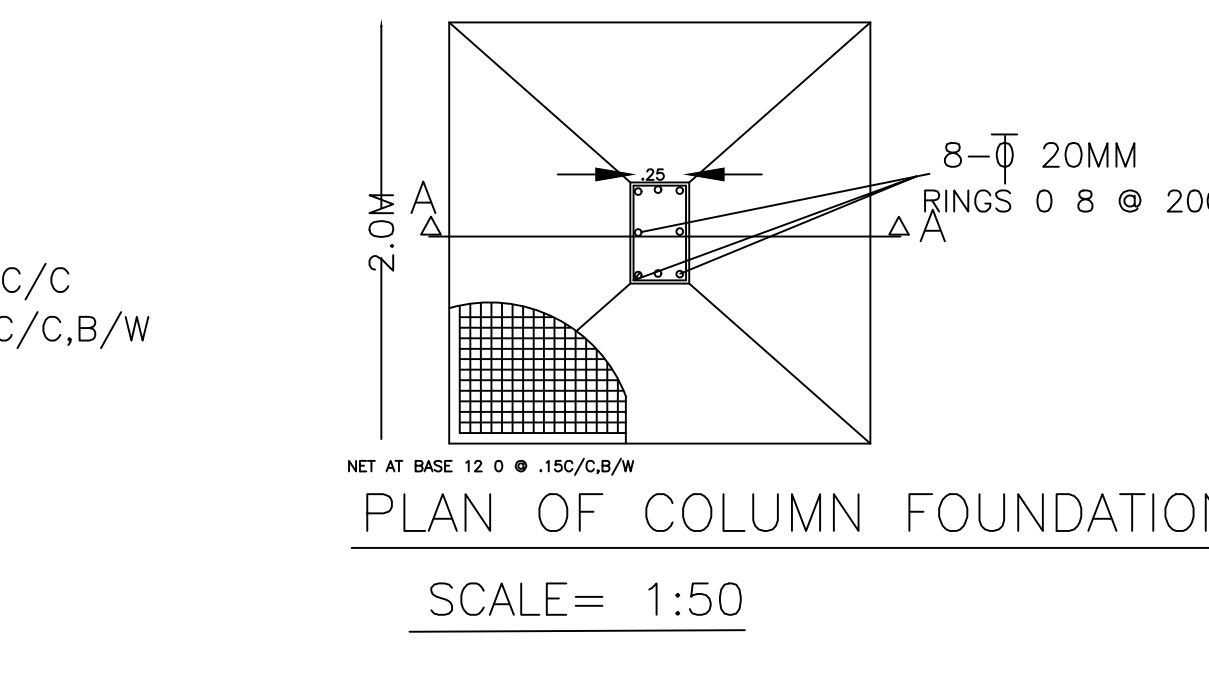
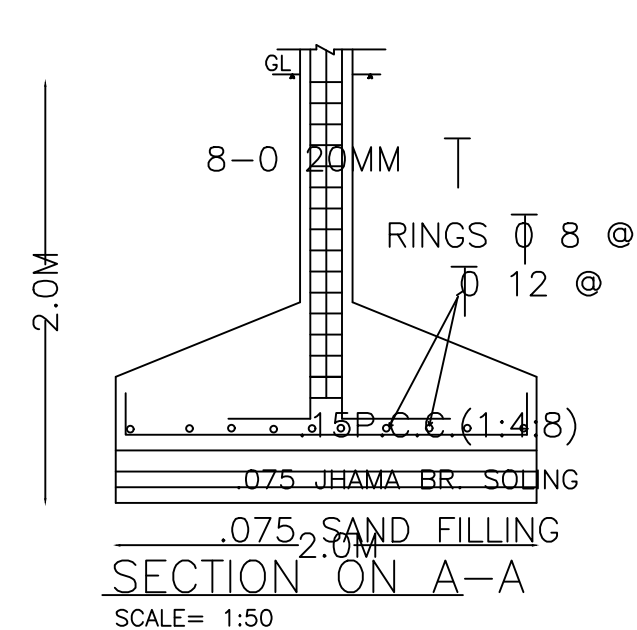
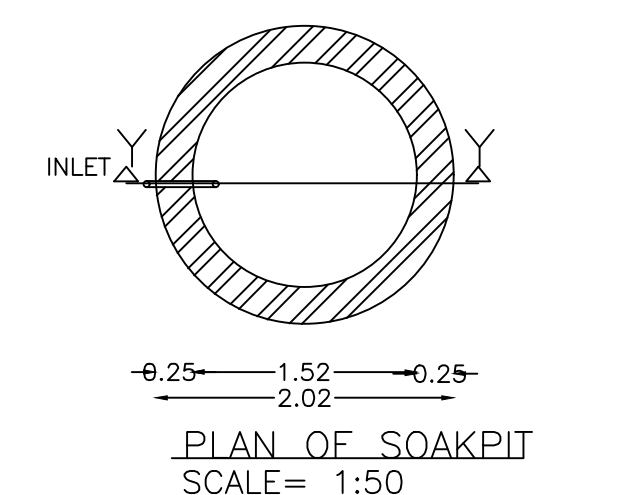
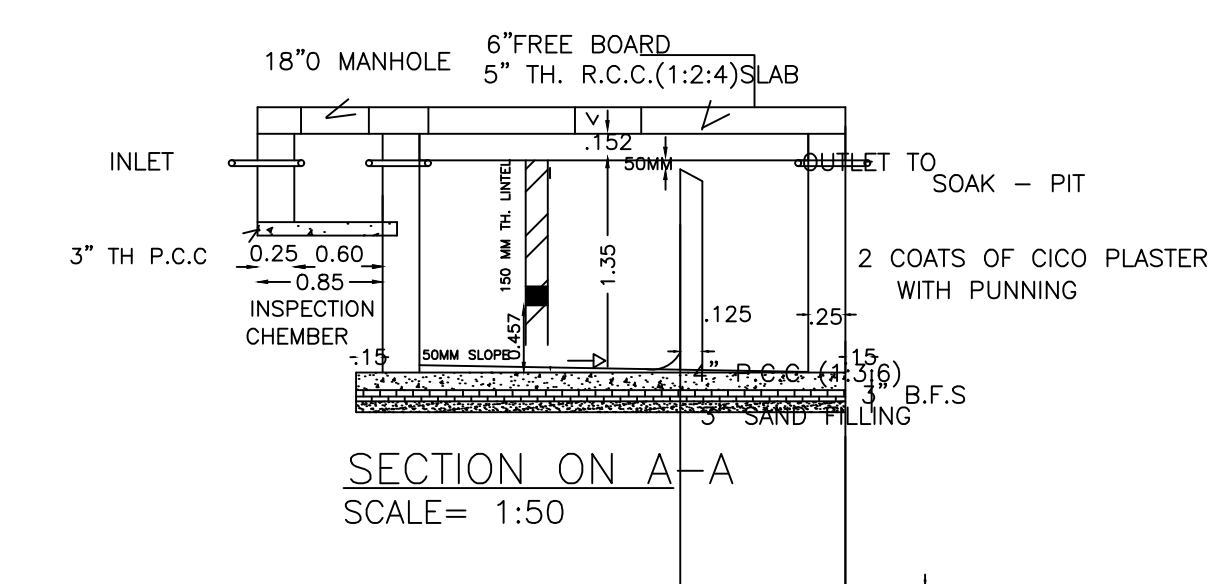
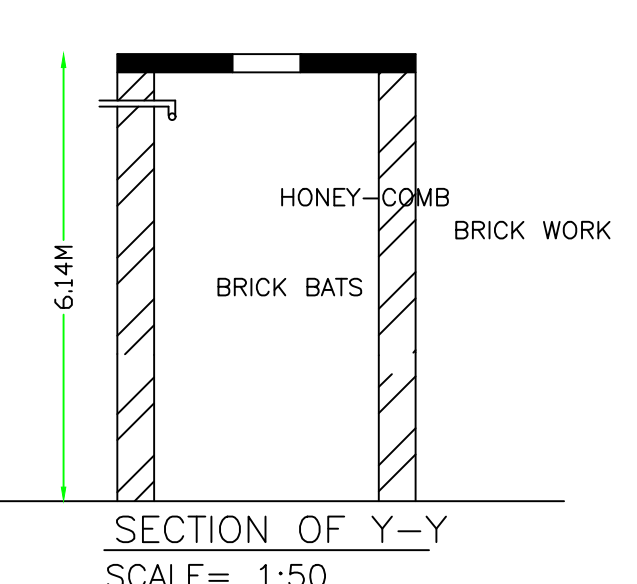

UnitBUA Table for Building :A (BUILDING)

FLOOR	Name	UnitBUA Type	UnitBUA Area	Carpet Area	No. of Rooms	No. of Tenement
GROUND FLOOR PLAN	ENTRANCE	OTHER	95.23	95.10	1	9
	HALL	OTHER	107.58	107.16	2	
	HALL B	OTHER	347.92	345.87	1	
	KITCHEN	OTHER	51.57	51.31	1	
	OFFICE 1	OFFICE	229.70	229.40	1	
	OFFICE 2	OFFICE	157.88	157.59	1	
	OFFICE 3	OFFICE	194.31	193.66	1	
	PLAZA	OTHER	120.56	120.43	1	
	SPLIT B	OTHER	55.58	54.84	5	
	C SPACE	OTHER	234.97	234.15	1	
FIRST FLOOR PLAN	C SPACE 2	OTHER	209.05	208.36	2	6
	C SPACE 3	OTHER	140.05	138.99	1	
	ROOM	OTHER	55.58	55.23	6	
	ROOM 2	OTHER	37.84	37.58	4	
	SUIT	OTHER	90.42	90.12	7	
	DINING	OTHER	94.62	94.00	4	
	OFFICE 4	OFFICE	229.46	228.80	1	
	OFFICE 5	OFFICE	111.20	107.91	1	
	OFFICE 6	OFFICE	139.83	138.48	1	
	OFFICE 7	OFFICE	209.21	208.23	2	
SECOND FLOOR PLAN	ROOM 2	OTHER	55.58	55.23	6	8
	ROOM 3	OTHER	37.84	37.58	4	
	SUIT	OTHER	99.46	99.15	7	
	office 10	OFFICE	140.05	139.83	1	
	office 11	OFFICE	231.02	230.61	1	
	office 8	OFFICE	109.66	109.40	1	
	office 9	OFFICE	209.20	208.55	2	
	ROOM 3	OTHER	37.84	37.69	4	
	office 15	OFFICE	231.02	230.61	1	
	office 16	OFFICE	109.66	109.40	1	
THIRD FLOOR PLAN	office 17	OFFICE	209.20	208.55	2	5
	office 18	OFFICE	140.05	139.83	1	
	ROOM 5	OTHER	37.84	37.69	4	
	office 19	OFFICE	231.02	230.61	1	
	office 20	OFFICE	109.66	109.40	1	
	office 21	OFFICE	209.20	208.55	2	
	office 22	OFFICE	140.05	139.83	1	
	ROOM 6	OTHER	37.84	37.69	4	
	office 11	OFFICE	231.02	230.61	1	
	office 12	OFFICE	109.66	109.40	1	
FIFTH FLOOR PLAN	office 13	OFFICE	209.20	208.55	2	5
	office 14	OFFICE	140.05	139.83	1	
	ROOM 4	OTHER	37.84	37.69	4	
	office 11	OFFICE	231.02	230.61	1	
	office 12	OFFICE	109.66	109.40	1	
	office 13	OFFICE	209.20	208.55	2	
	office 14	OFFICE	140.05	139.83	1	
	ROOM 4	OTHER	37.84	37.69	4	
	office 11	OFFICE	231.02	230.61	1	
	office 12	OFFICE	109.66	109.40	1	
SIXTH FLOOR PLAN	office 13	OFFICE	209.20	208.55	2	5
	office 14	OFFICE	140.05	139.83	1	
	ROOM 4	OTHER	37.84	37.69	4	
	office 11	OFFICE	231.02	230.61	1	
	office 12	OFFICE	109.66	109.40	1	
	office 13	OFFICE	209.20	208.55	2	
	office 14	OFFICE	140.05	139.83	1	
	ROOM 4	OTHER	37.84	37.69	4	
	office 11	OFFICE	231.02	230.61	1	
	office 12	OFFICE	109.66	109.40	1	
Total	-	-	6016.51	5993.53	97	43

Required Parking(Table 7a)

Building Name	Type	SubUse	Area (Sq.mt.)	Units		Car		TwoWheeler	
				Reqd.	Prop.	Reqd./Unit	Prop.	Reqd./Unit	Prop.
A (BUILDING)	Commercial	Bldg	> 0	200	6130.56	1	21	-	-
A (BUILDING)	Commercial	Bldg	> 0	200	6130.56	-	-	1	64
Total	-	-	-	-	-	-	21	28	64

Parking Check (Table 7b)

Vehicle Type	Reqd.		Prop.	
	No.	Area	No.	Area
Car	-	-	28	350.00
Total Car	21	262.50	28	350.00
TwoWheeler	-	-	66	132.00
Total TwoWheeler	64	128.00	66	132.00
Other Parking	-	-	-	476.05
Total	-	390.50	-	1090.05

Building USE/SUBUSE Details

Building Name	Building Use	Building SubUse	Building Structure
A (BUILDING)	Commercial	Commercial Bldg	Multistored

COLOR INDEX

PLOT BOUNDARY	Black
ABUTTING ROAD	Green
PROPOSED CONSTRUCTION	Red
COMMON PLOT	Yellow
ROAD WIDENING AREA	Blue
EXISTING (To be retained)	Orange
EXISTING (To be demolished)	Grey

LTP NAME AND SIGNATURE	STRUCTURAL ENG'S NAME AND SIGNATURE	BUILDER NAME AND SIGNATURE	DIGITAL SIGNATURE
RAJIV CHADDA JIADA/ARC/0006/2019			

