

Proposed Basic Information			
Proposal File No.	JADA/BP/001/2021		
Owner Name	PUNIT KUMAR POGDAR		
Khata No.	20, 40		
Plot No.	Survey/Plot No. 535P, 535P, Industrial Plot No. IX A		
Village Name	Sudra		
Use	Commercial		
SubUse	Services or Repair establishments		
AREA STATEMENT	VERSION NO.: 1.0.54		
JHARKHAND INDUSTRIAL AREA DEVELOPMENT AUTHORITY	VERSION DATE: 16/10/2020		
PROJECT DETAIL			
Region: JHARKHAND URBAN LOCAL BODIES	Plot Use: Commercial		
District: RANCHI	Plot SubUse: Services or Repair establishments		
Authority: JHARKHAND INDUSTRIAL AREA DEVELOPMENT AUTHORITY	Plot Nearby/Religious/Structure: NA		
Inward No.: JADA/BP/001/2021	Plot/SubPlot No.: Survey Plot No. 535P, 535P, Industrial Plot No. IX A		
Application Type: General Proposal	North: Survey No. - 535P, 535P and Industrial Plot No. 35		
Project Type: Building Permission	South: Survey No. - 535P and Industrial Plot No. IX B		
Nature of Development: New	East: Survey No. - 535P and Industrial Boundary		
Location of Development Area: New Area	West: Road Width - 12.2		
AREA DETAILS			
AREA OF PLOT (Minimum)	(A)	SQ.MT.	2427.61
NET AREA OF PLOT (Gross Plot Area - Deduction from Gross Plot area)	(A-Deductions)		2427.61
Deduction for Balance Plot Area (from Gross Plot Area)			
Common Plot			123.26
Total			123.26
BALANCE AREA OF PLOT (Net Plot Area - Recreational/Amenity space)	(A-Deductions)		2304.35
PLOT AREA FOR COVERAGE (Net Plot Area)	(A-Deductions)		2427.61
Plot Area for FAR (Net Plot Area - Road Widening Area)	(A-Deductions)		2427.61
COVERAGE CHECK			
Permissible Coverage area (50.00 %)			1213.81
Proposed Coverage Area (44.44 %)			1078.93
Total Prop. Coverage Area (44.44 %)			1078.93
Balance coverage area (5.56 %)			134.88
FAR CHECK			
Perm. FAR Area (2.50)			6069.03
Total Perm. FAR Area			6069.03
Commercial FAR			1232.20
Proposed FAR Area			1232.20
Total Proposed FAR Area			1232.20
Conserved FAR (Factor)			0.51
Balance FAR Area			4836.83
BUILT UP AREA CHECK			
Total Proposed BuiltUp Area			1232.20
ARCHITECT (Regd)			
ARCHITECT (Regd)			Nishi Jani
ENGINEER (Regd)			
ENGINEER (Regd)			
SUPERVISOR (Regd)			
SUPERVISOR (Regd)			
OWNER (Regd)			
OWNER (Regd)			PUNIT KUMAR POGDAR
DEVELOPMENT AUTHORITY			
LOCAL BODY			

COLOR INDEX	
ABUTTING ROAD	Red
PROPOSED CONSTRUCTION	Green
COMMON PLOT	Yellow
ROAD WIDENING AREA	Blue
EXISTING (To be retained)	Grey
EXISTING (To be demolished)	White

Buildingwise Floor FAR Details				
Floor Name	Proposed Built Up Area (Sq.mt)	Proposed FAR Area (Sq.mt)	Total Proposed Built Up Area (Sq.mt)	Total FAR Area (Sq.mt)
Ground Floor	153.27	153.27	153.27	153.27
First Floor	0.00	0.00	0.00	0.00
Terrace Floor	0.00	0.00	0.00	0.00
Total	153.27	153.27	153.27	153.27

Building USE/SUBUSE Details				
Building Name	Building Use	Building SubUse	Building Structure	
A (SERVICE CENTER)	Commercial	Services or Repair establishments	Non-Highrise	

Required Parking (Table 7a)										
Building Name	Type	SubUse	Area (Sq.mt)	Reqd.	Prop.	Reqd./Unit	Car	Prop.	Two/Wheeler	Prop.
A (SERVICE CENTER)	Commercial	Services or Repair establishments	>0	200	1218.39	1	5	-	-	-
Total				200	1218.39		5	24	13	16

Parking Check (Table 7b)				
Vehicle Type	No.	Area	No.	Area
Car	5	62.50	24	300.00
Two/Wheeler	13	26.00	16	32.00
Total	18	88.50	40	332.00

FAR & Tenement Details (Table 4c-1)								
Building	No. of Same Bldg	Gross Built Up Area (Sq.mt)	Deductions From Gross BUA Area (Sq.mt)	Total Built Up Area (Sq.mt)	Proposed FAR Area (Sq.mt)	Total FAR Area (Sq.mt)	Total Consumed Additional FAR Area (Sq.mt)	Tenmt (No.)
A (SERVICE CENTER)	1	2148.71	917.51	1232.20	1232.20	1232.20	1232.20	02
Grand Total	1	2148.71	917.51	1232.20	1232.20	1232.20	1232.20	02

Building -A (SERVICE CENTER)							
Floor Name	Gross Built Up Area (Sq.mt)	Deductions From Gross BUA Area (Sq.mt)	Total Built Up Area (Sq.mt)	Proposed FAR Area (Sq.mt)	Total FAR Area (Sq.mt)	Total Consumed Additional FAR Area (Sq.mt)	Tenmt (No.)
Ground Floor	1078.93	0.00	1078.93	1078.93	1078.93	01	01
First Floor	1078.78	917.51	153.27	153.27	153.27	01	01
Terrace Floor	0.00	0.00	0.00	0.00	0.00	00	00
Total	2148.71	917.51	1232.20	1232.20	1232.20	02	02

SCHEDULE OF DOOR:				
BUILDING NAME	NAME	LENGTH	HEIGHT	NOS
A (SERVICE CENTER)	D1	0.75	2.10	02
A (SERVICE CENTER)	D2	0.90	2.10	11
A (SERVICE CENTER)	D1	0.91	2.10	03
A (SERVICE CENTER)	D	1.00	2.10	04
A (SERVICE CENTER)	D'	1.50	2.10	08
A (SERVICE CENTER)	RS	2.50	2.10	01

SCHEDULE OF WINDOW/VENTILATION:				
BUILDING NAME	NAME	LENGTH	HEIGHT	NOS
A (SERVICE CENTER)	V1	0.47	1.80	01
A (SERVICE CENTER)	V	0.60	0.60	02
A (SERVICE CENTER)	W2	0.79	1.80	02
A (SERVICE CENTER)	W1	1.18	1.80	01
A (SERVICE CENTER)	W1	1.20	1.80	08
A (SERVICE CENTER)	SK	1.80	1.80	09

UnitBUA Table for Building -A (SERVICE CENTER)				
FLOOR	Name	UnitBUA Type	UnitBUA Area	No. of Tenement
GROUND FLOOR PLAN	OTHER	OTHER	1078.93	03
FIRST FLOOR PLAN	OTHER	OTHER	153.27	1
Total			1232.20	4

SITE PLAN

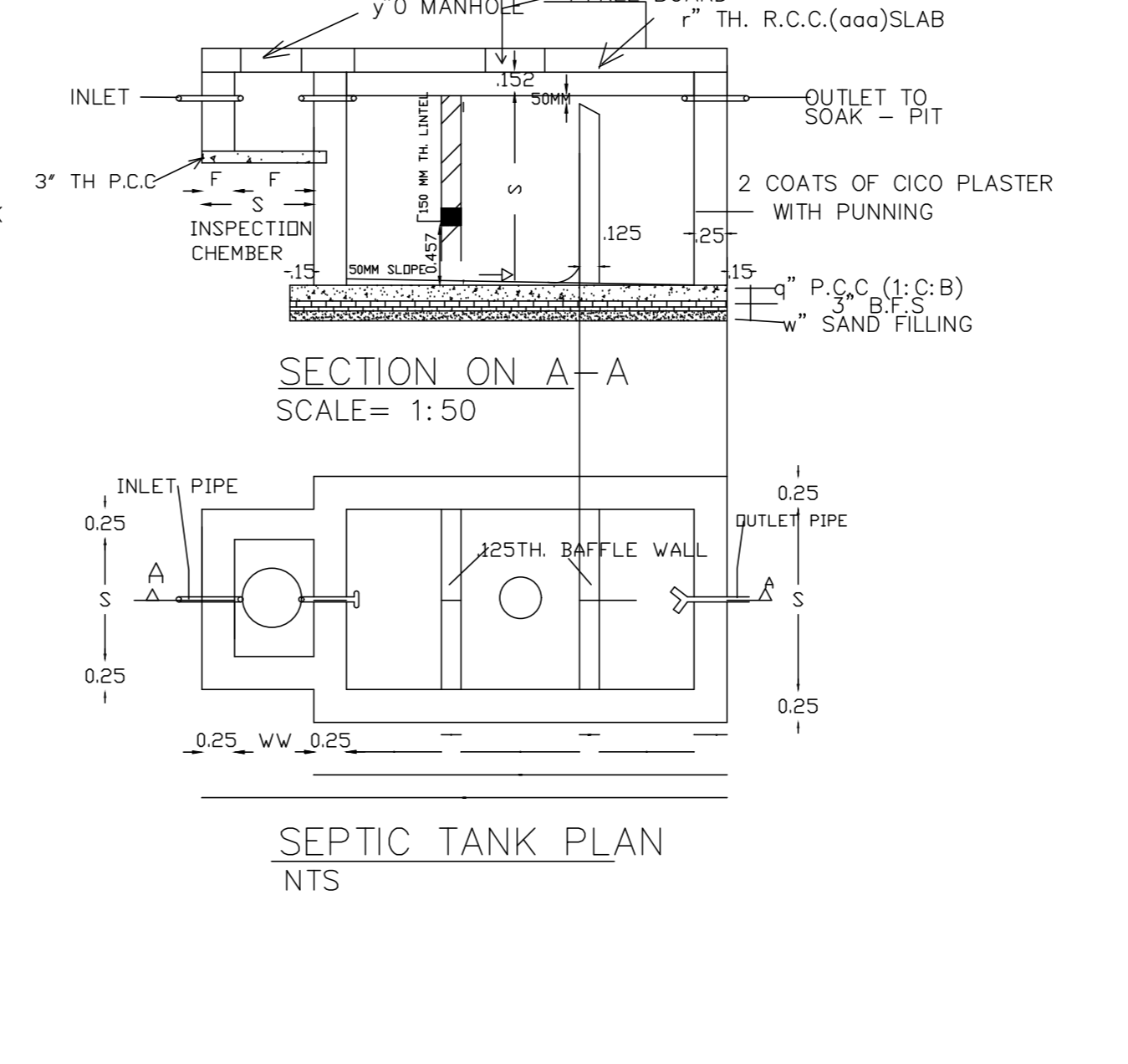
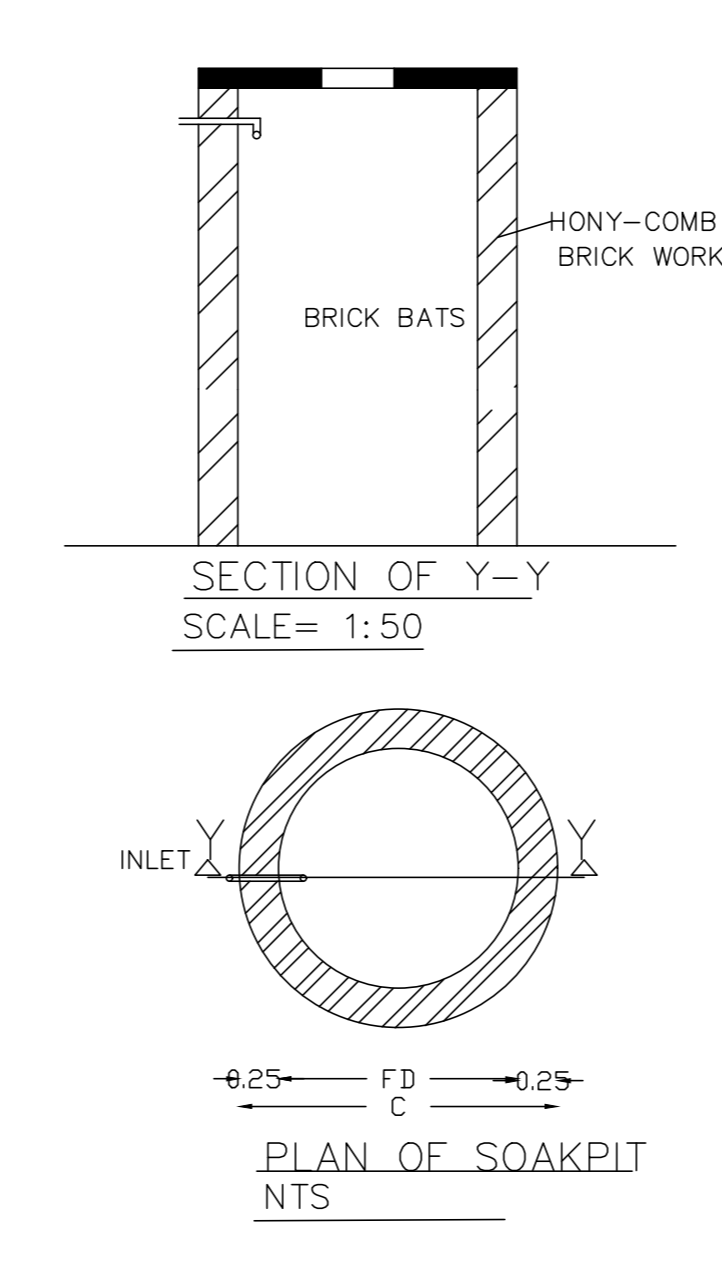
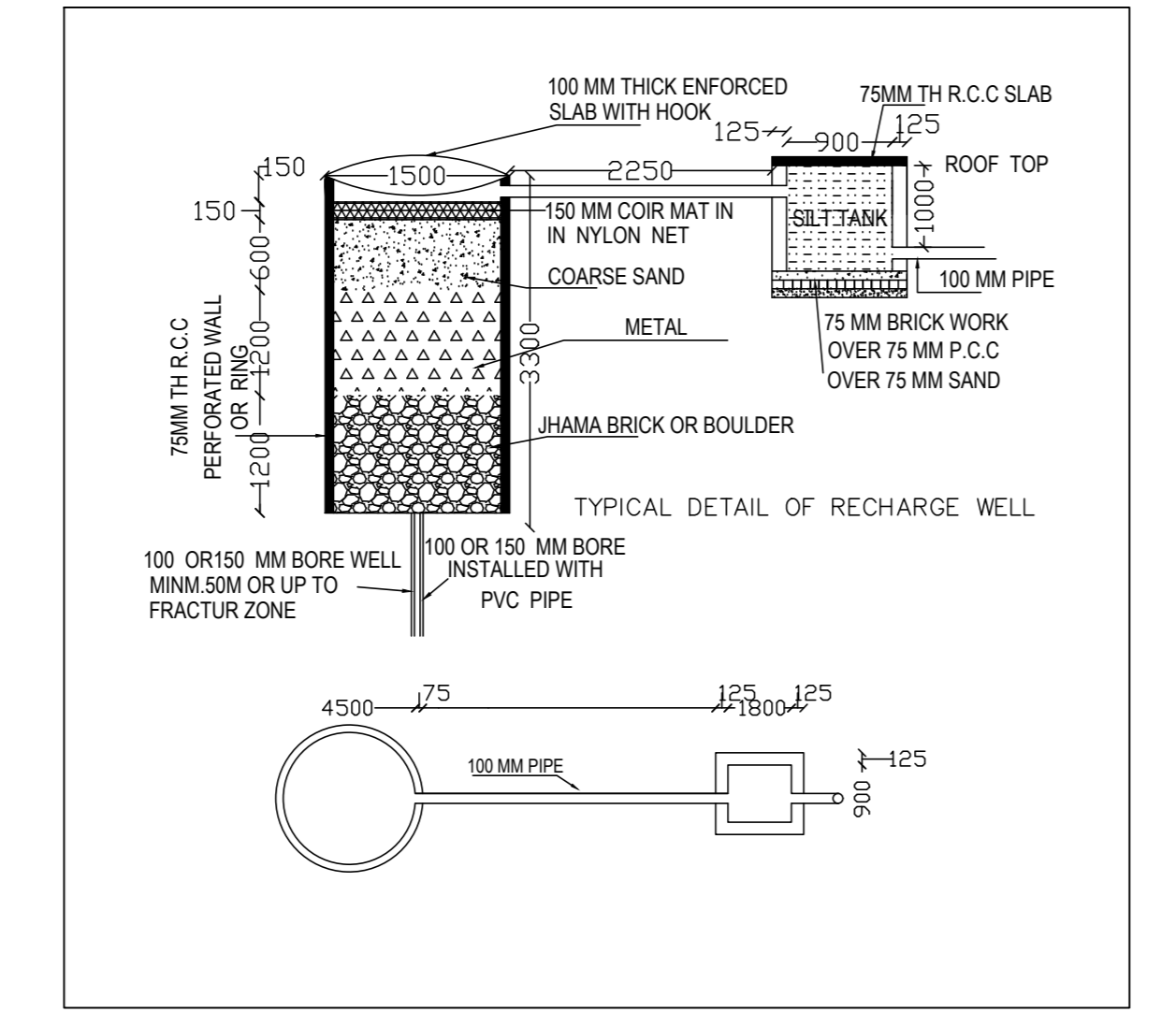
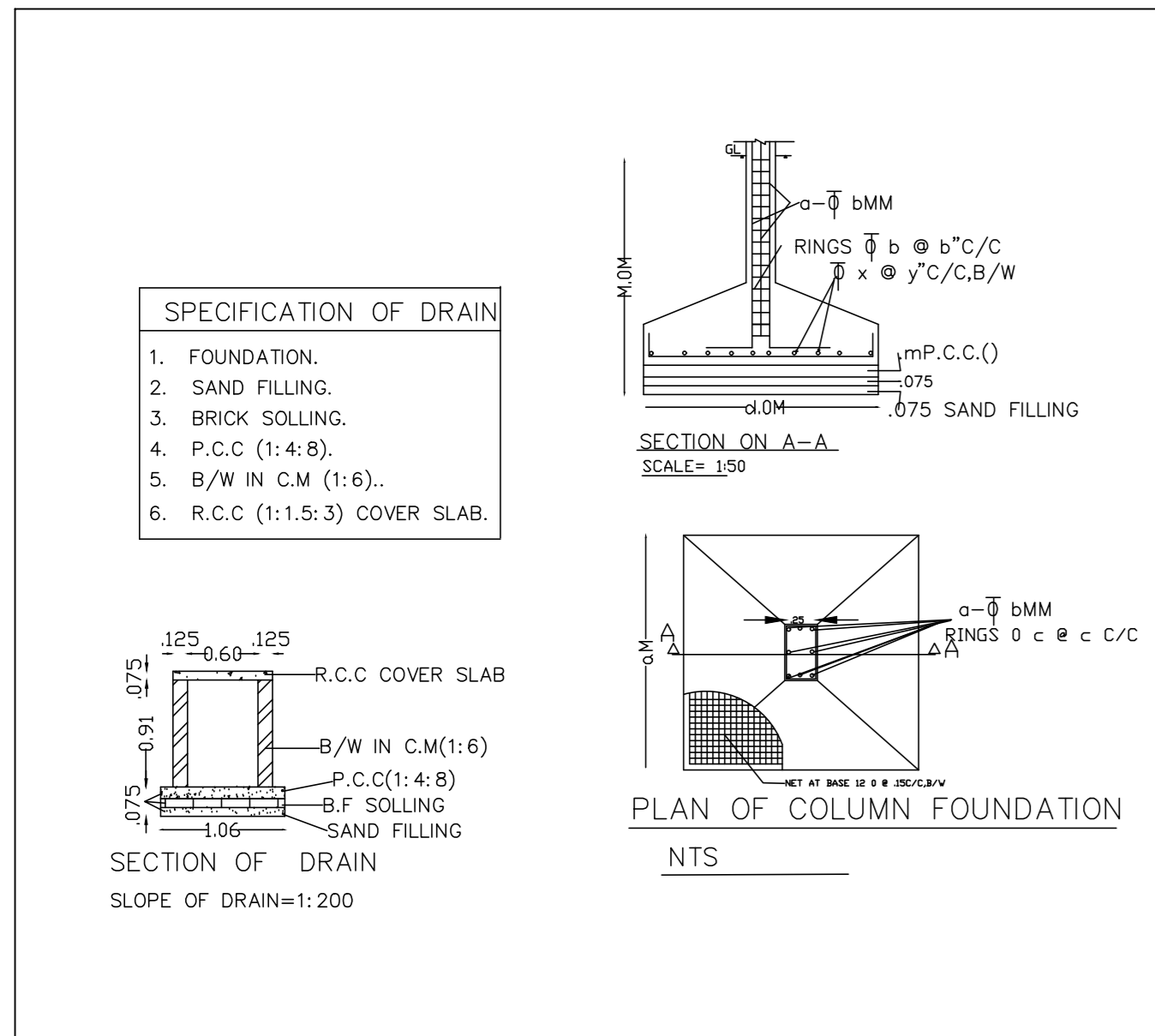

LTP NAME AND SIGNATURE: Nishi Jani, JADA/ARC/001/2021
STRUCTURAL ENGS NAME AND SIGNATURE: Nishi Jani
BUILDER NAME AND SIGNATURE: Punit Kumar Pogdar
DIGITAL SIGNATURE

Proposal Basic Information	
Proposal File No.	JADA/BP/001/2021
Owner Name	PUNIT KUMAR POGDAR
Khata No	20, 40
Plot No	Survey Plot No. 535P, 536P, Industrial Plot No. IXA
Village Name	Sudra
Use	Commercial
SubUse	Services or Repair establishments

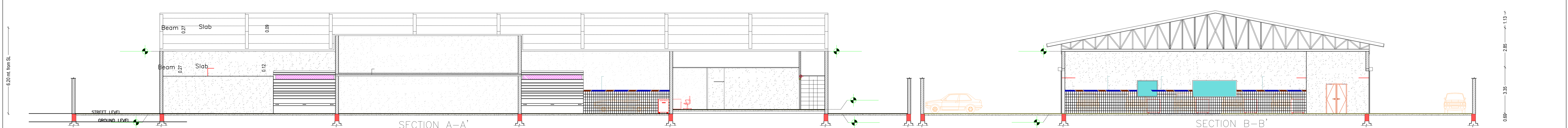
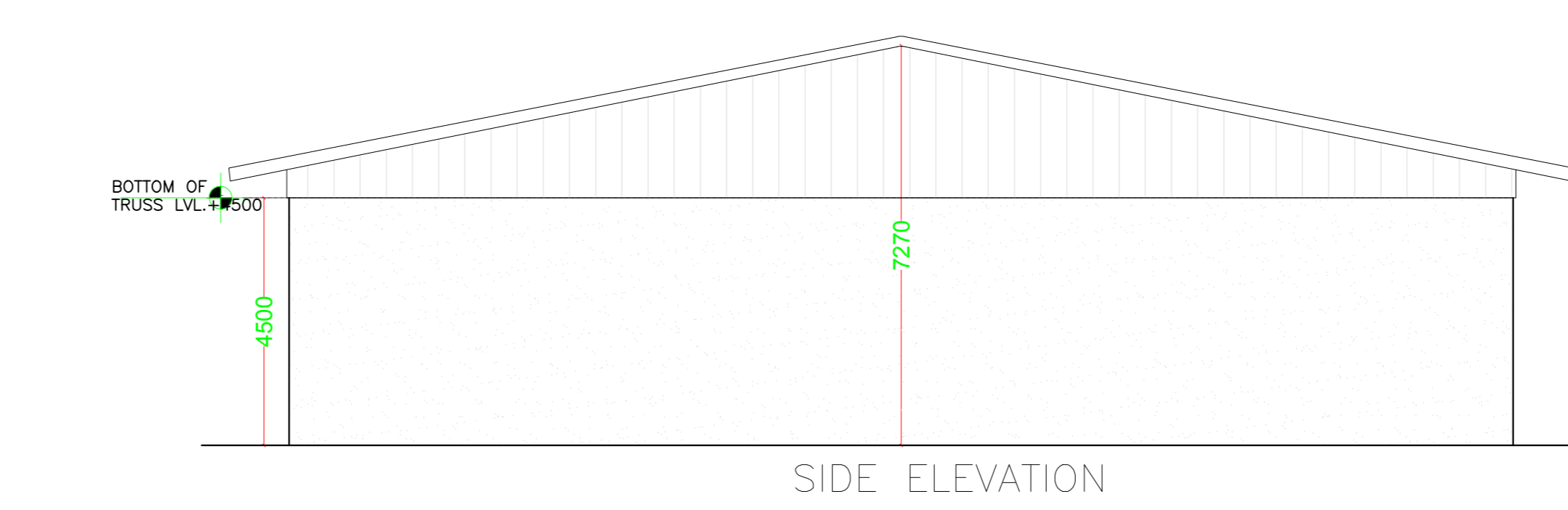
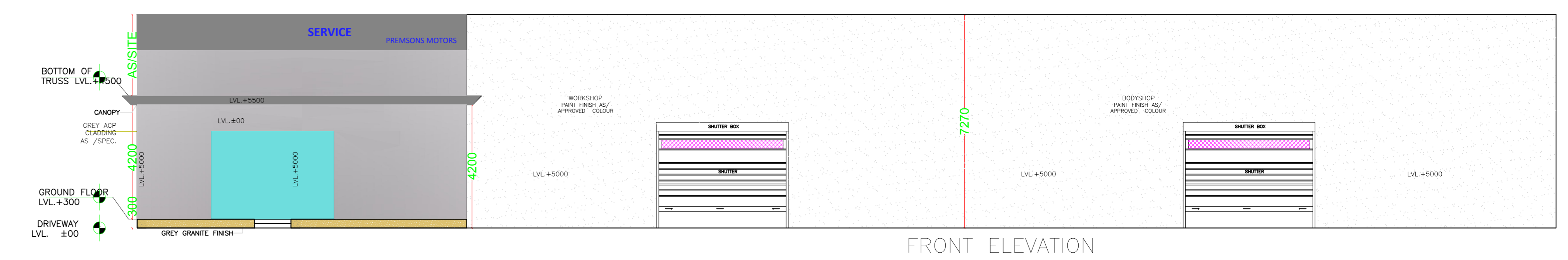
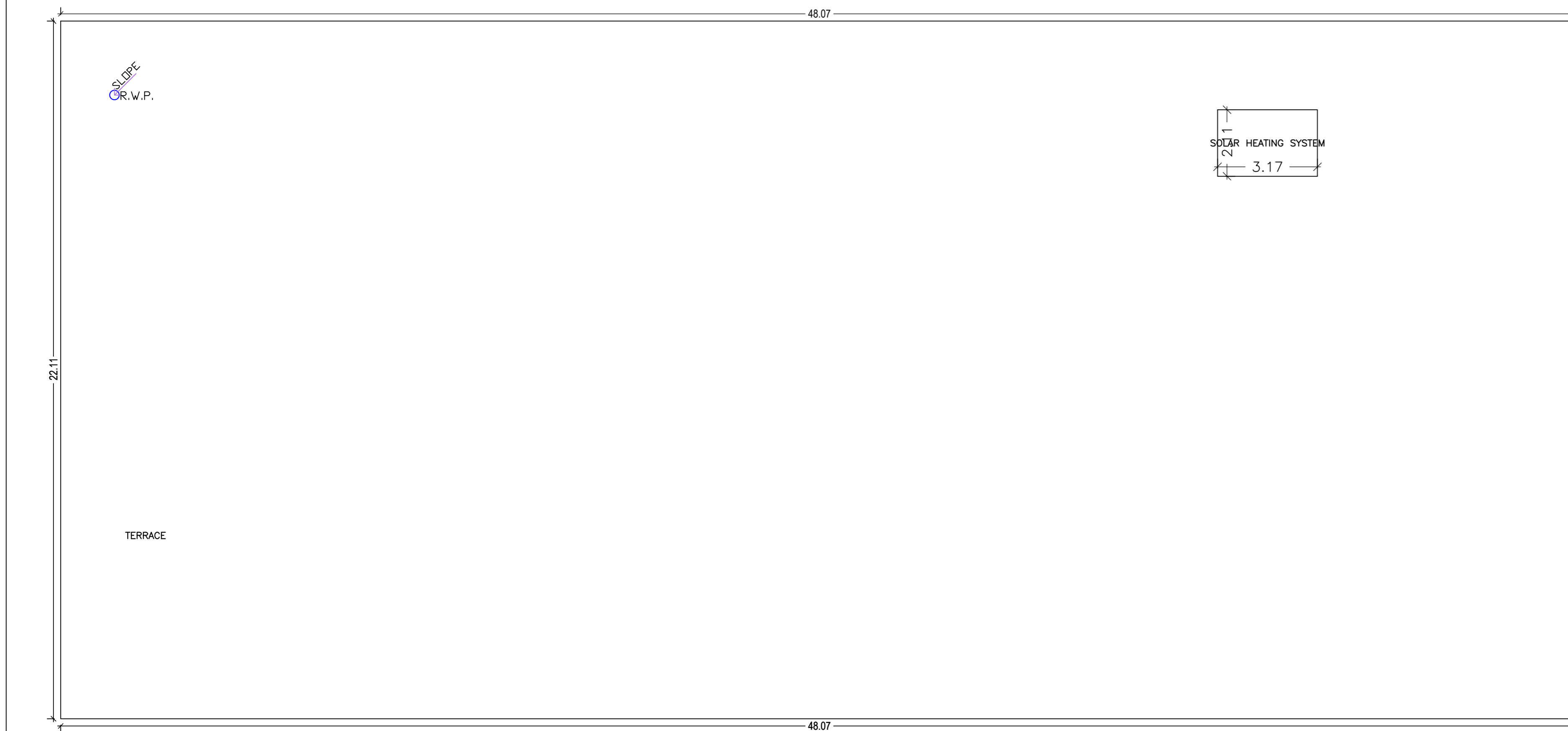
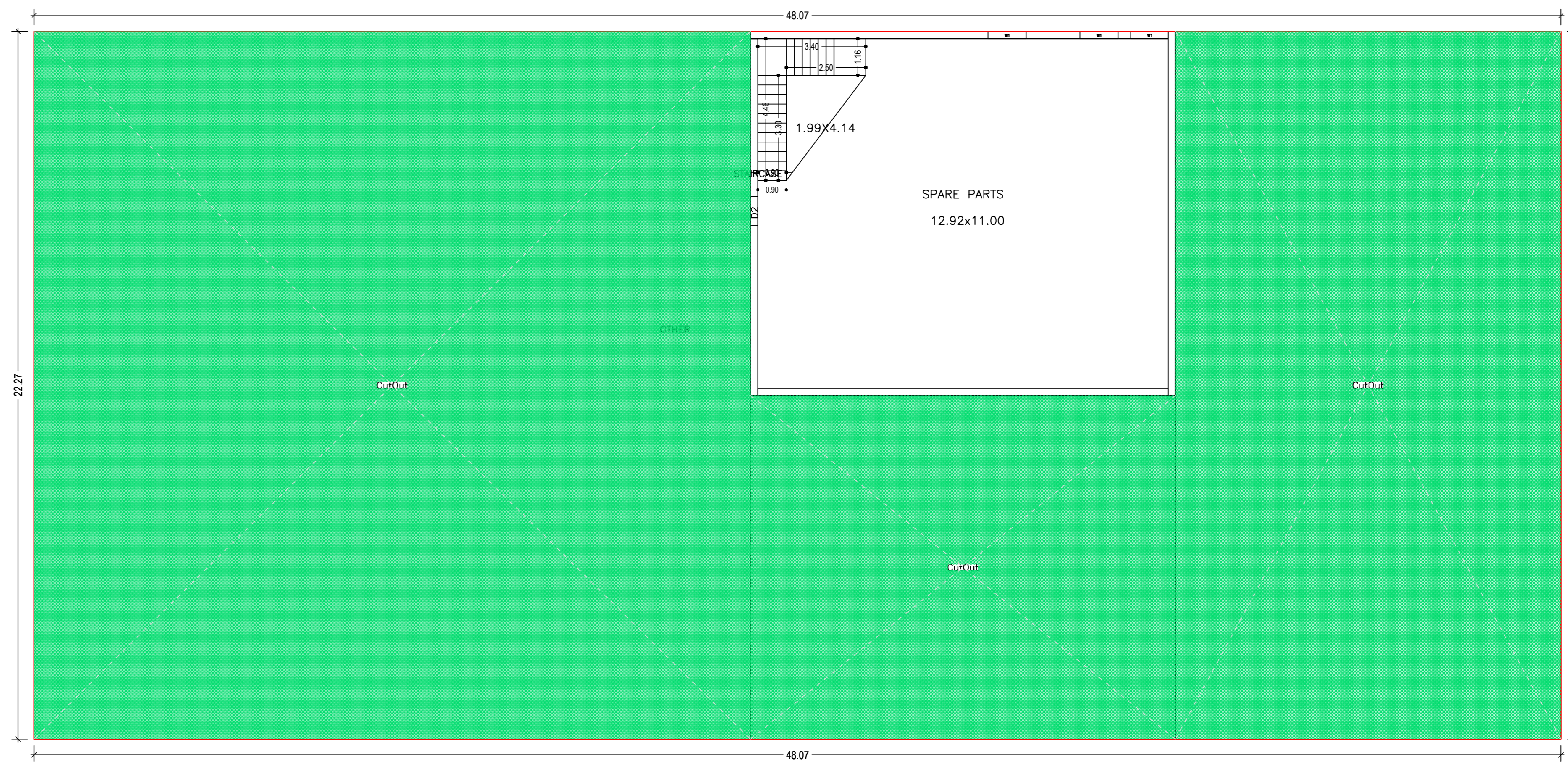
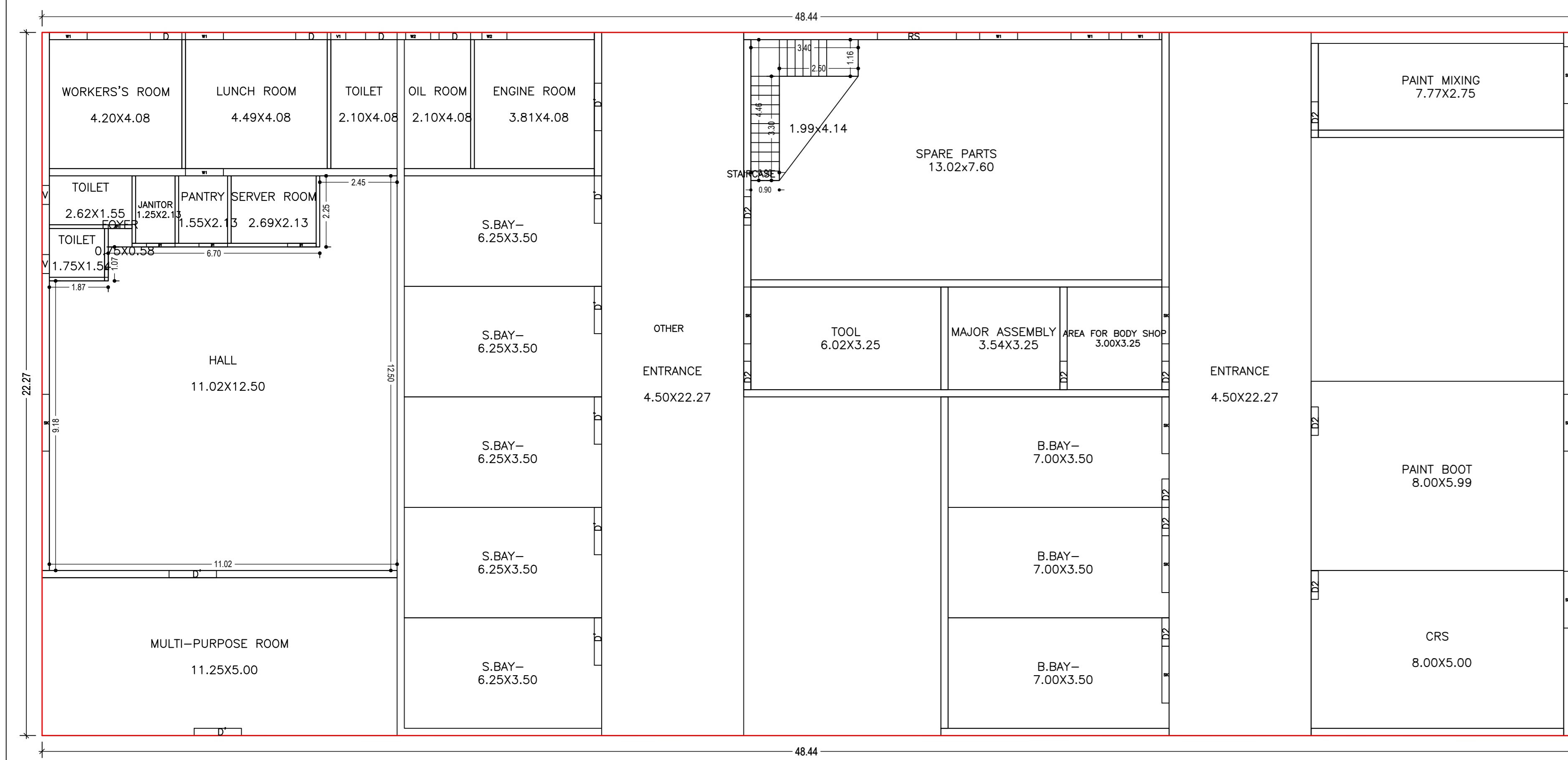

LTP NAME AND SIGNATURE	STRUCTURAL ENGS NAME AND SIGNATURE	BUILDER NAME AND SIGNATURE	DIGITAL SIGNATURE
Nikhil Jain JADA/NARC/001/2018			