

Project Title : M.S.PAVITRA PROMOTERS PRIVATE LIMITED DIRECTOR ARNAB CHAKRABORTY

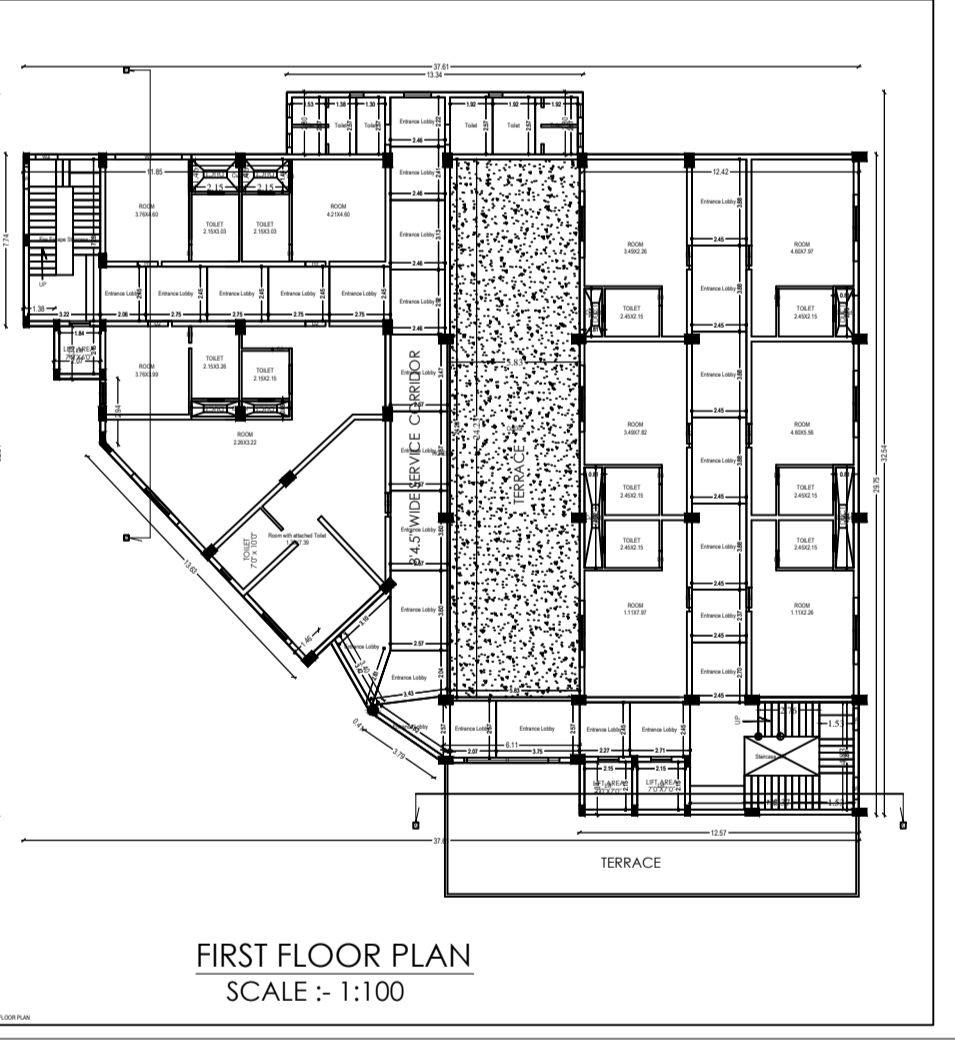
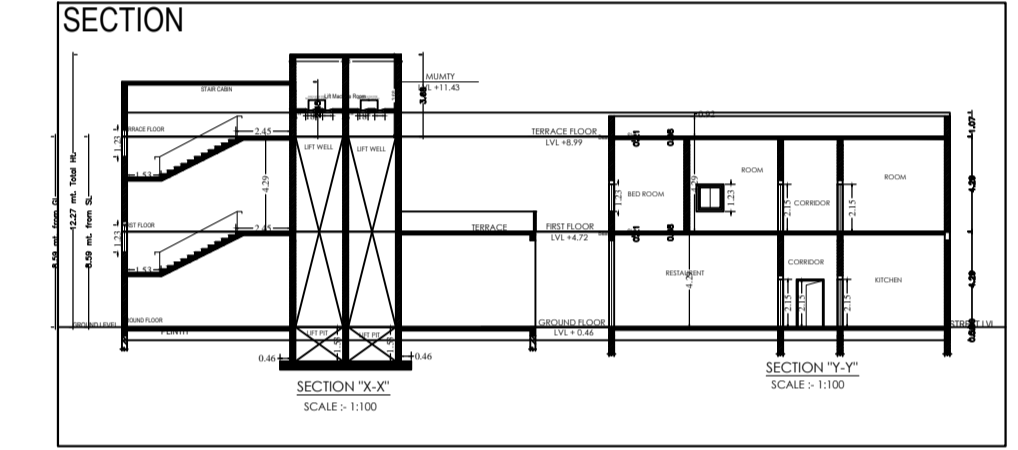
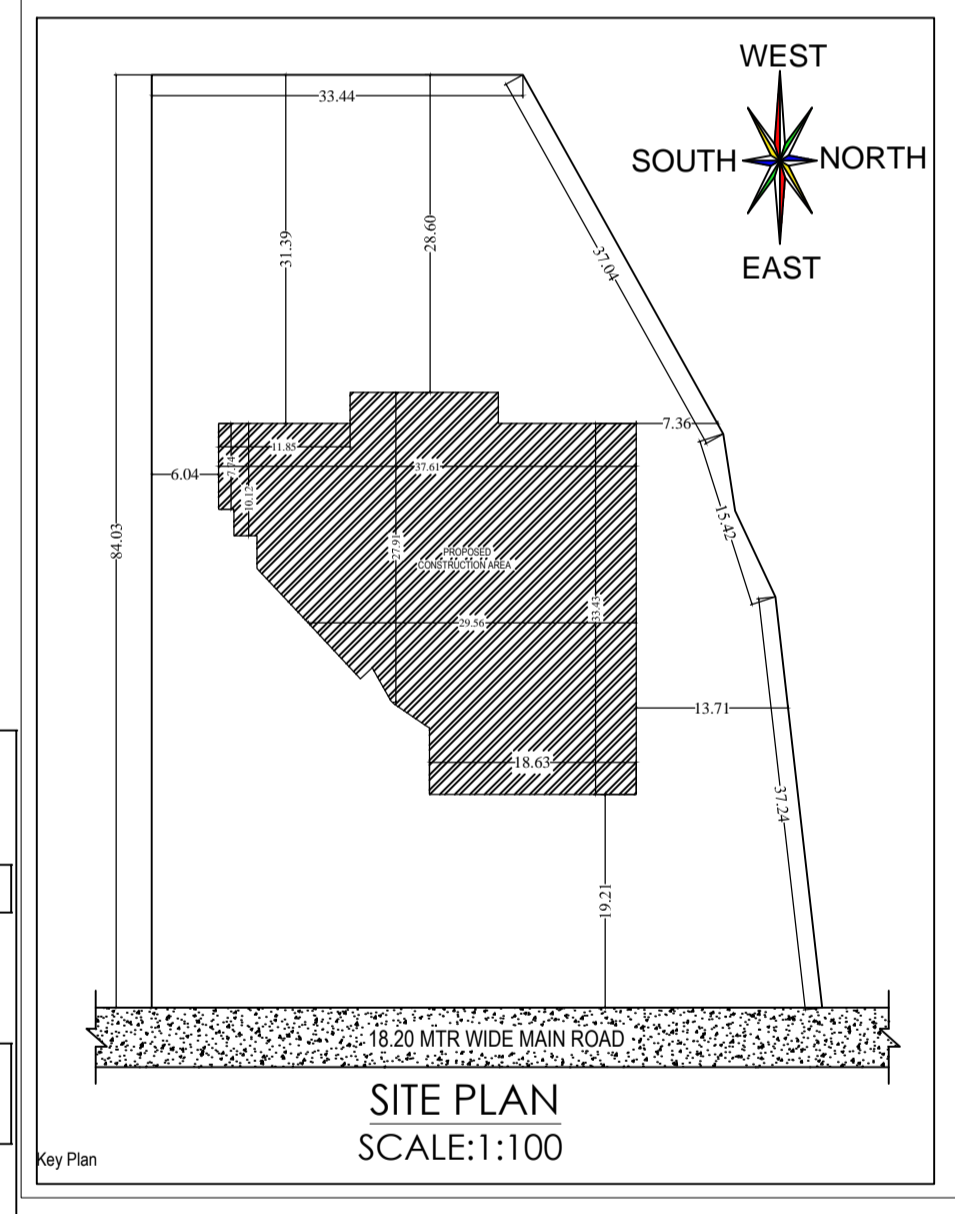
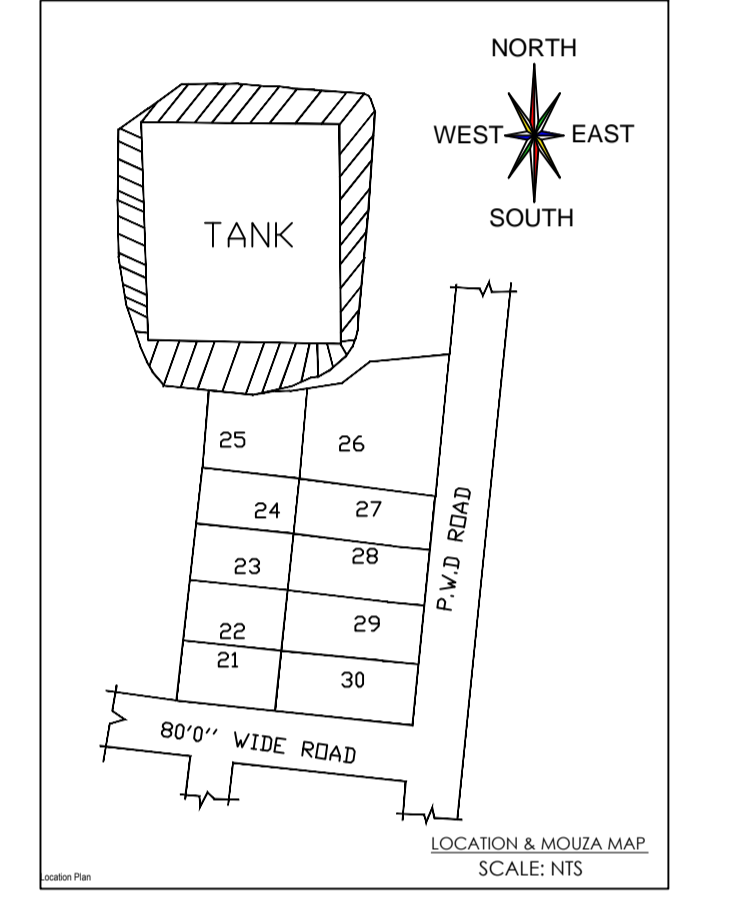
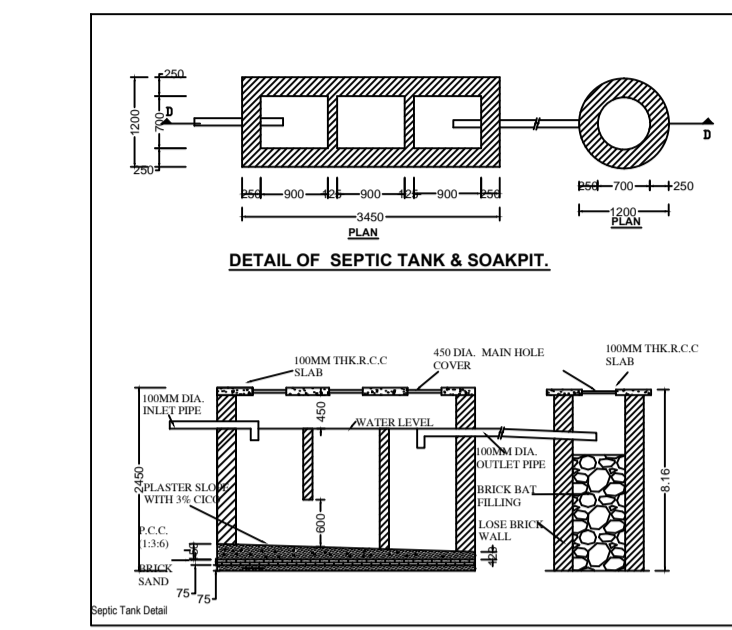
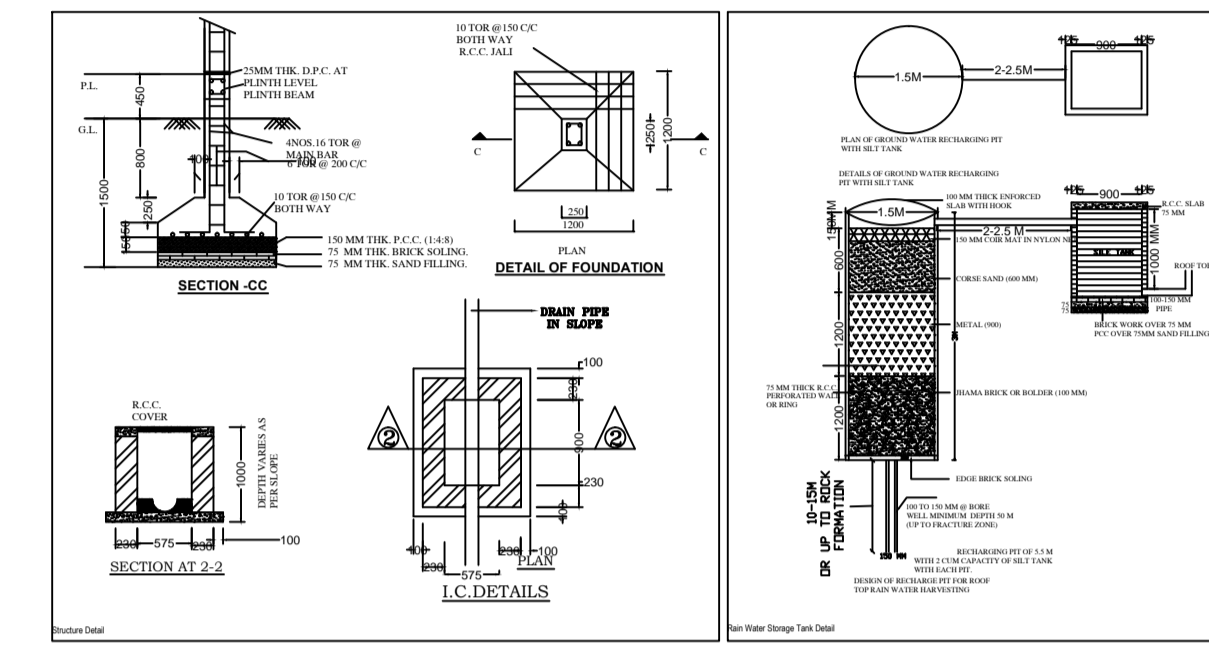
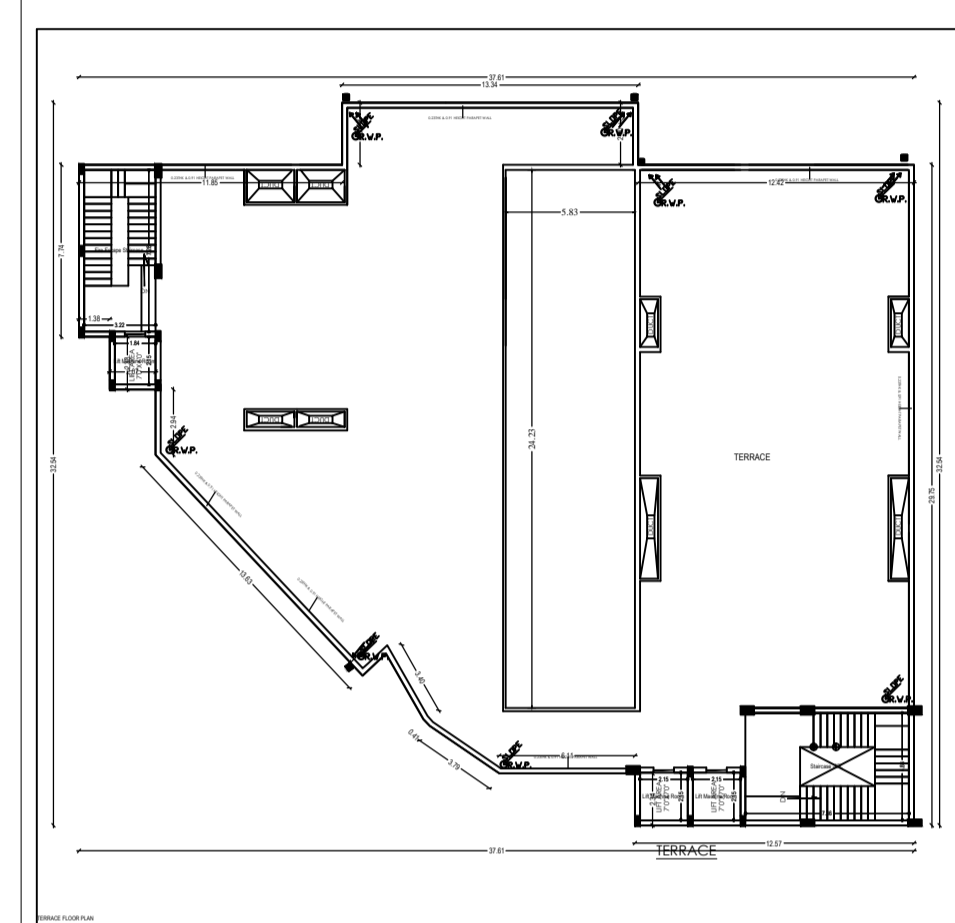
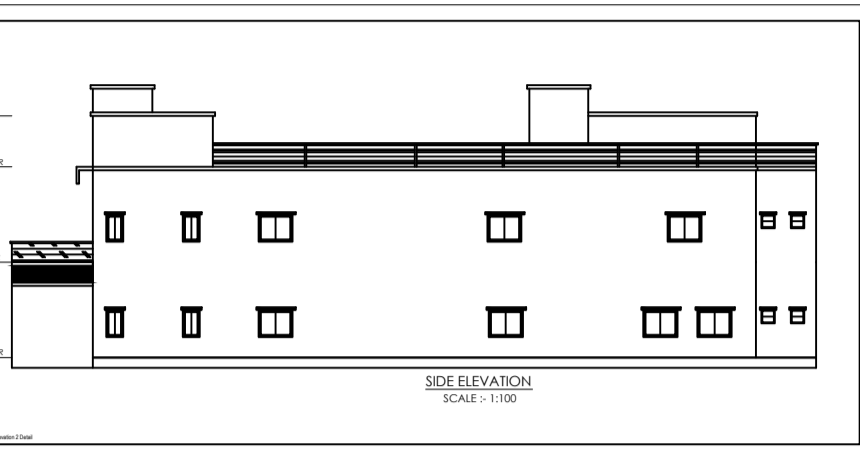
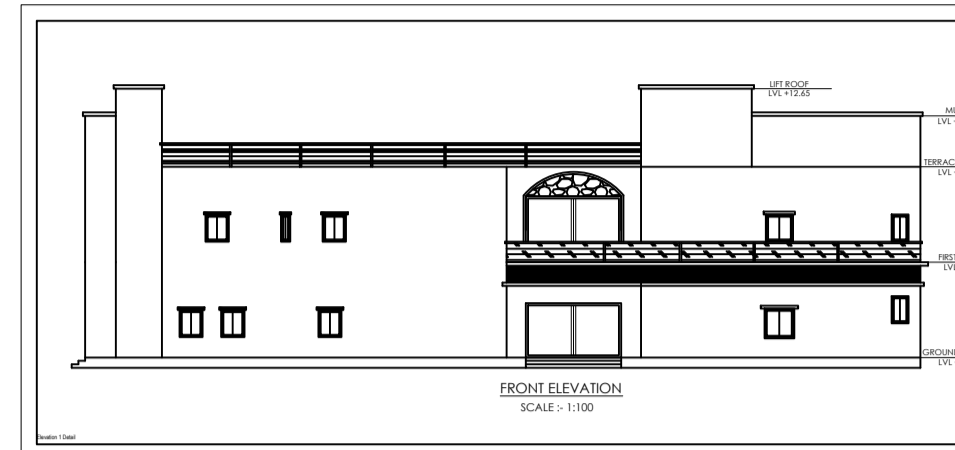
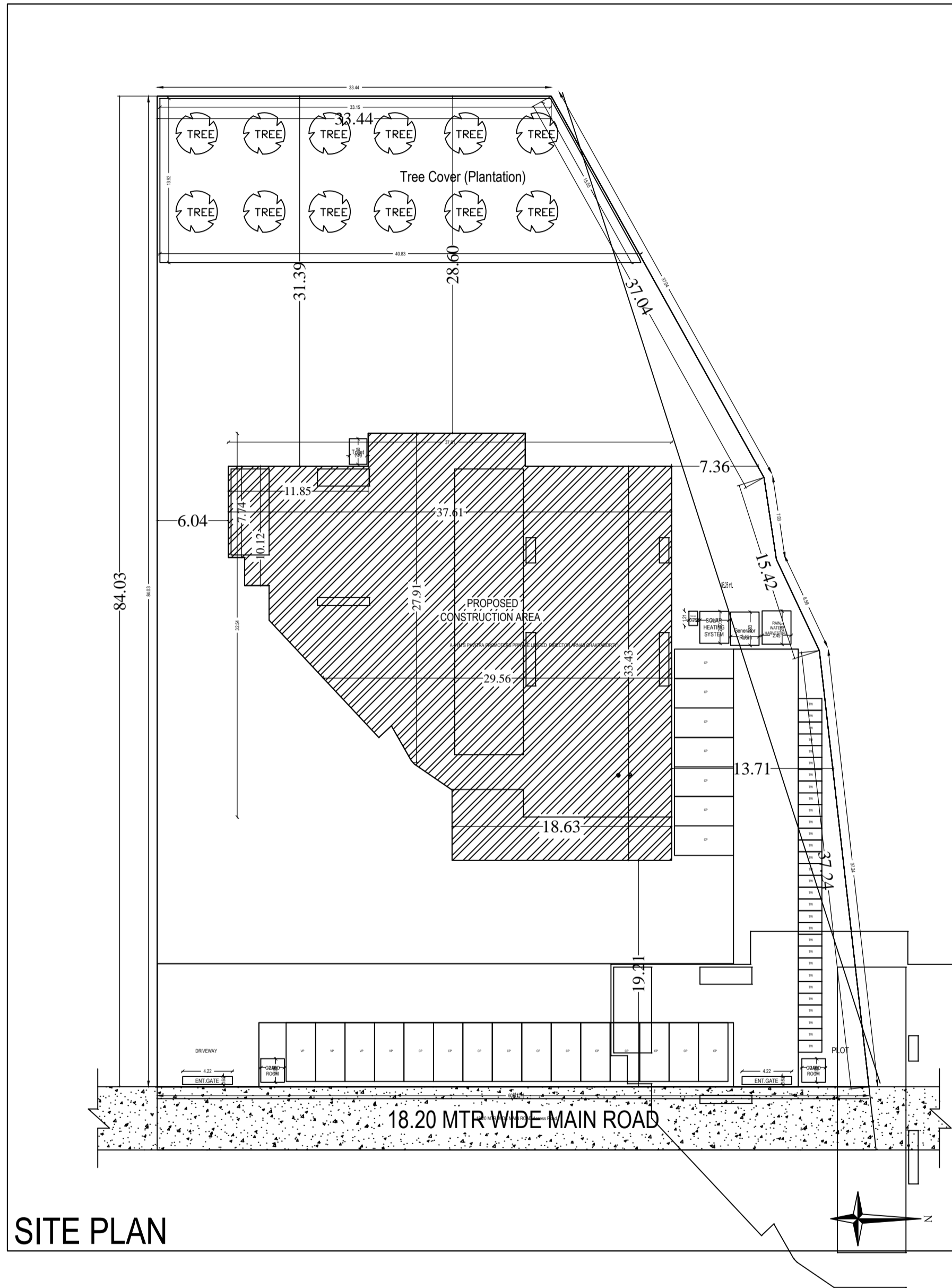

**PROPOSED HOTEL BUILDING PLAN FOR**  
**M/S PAVITRA PROMOTERS PRIVATE LIMITED**  
**(DIRECTOR)**  
**ARNAB CHAKRABORTY**  
PLOT NO :- 25 & 25 , KHATA NO- 1  
HOLDING NO. N/A  
WARD NO: - N/A, MOUZA- TUPUDANA  
P.S - RANCHI , THANA NO - 1  
DISTRICT :- RANCHI, JHARKHAND

SIGNATURE OF ENGINEER/ARCHITECT SIGNATURE OF LAND OWNER

GENERAL INFORMATION	
Project Name	M.S.PAVITRA PROMOTERS PRIVATE LIMITED DIRECTOR ARNAB CHAKRABORTY
Plot No.	25 & 25
Khata No.	1
Ward No.	N/A
Mouza	TUPUDANA
P.S.	RANCHI
Thana	NO - 1
District	RANCHI, JHARKHAND
Scale	1:100
Date	
Sheet No.	
Total Sheets	
Prepared By	
Checked By	
Approved By	
Scale	
Date	

PROPERTY TAX	
Year	2023-24
Assessment	...
Amount	...
Due Date	...
Remarks	...