

DETAIL OF RECHARGE WELL SECTION OF DRAIN
SCALE - N.T.S. SLOPE OF DRAIN=1:200

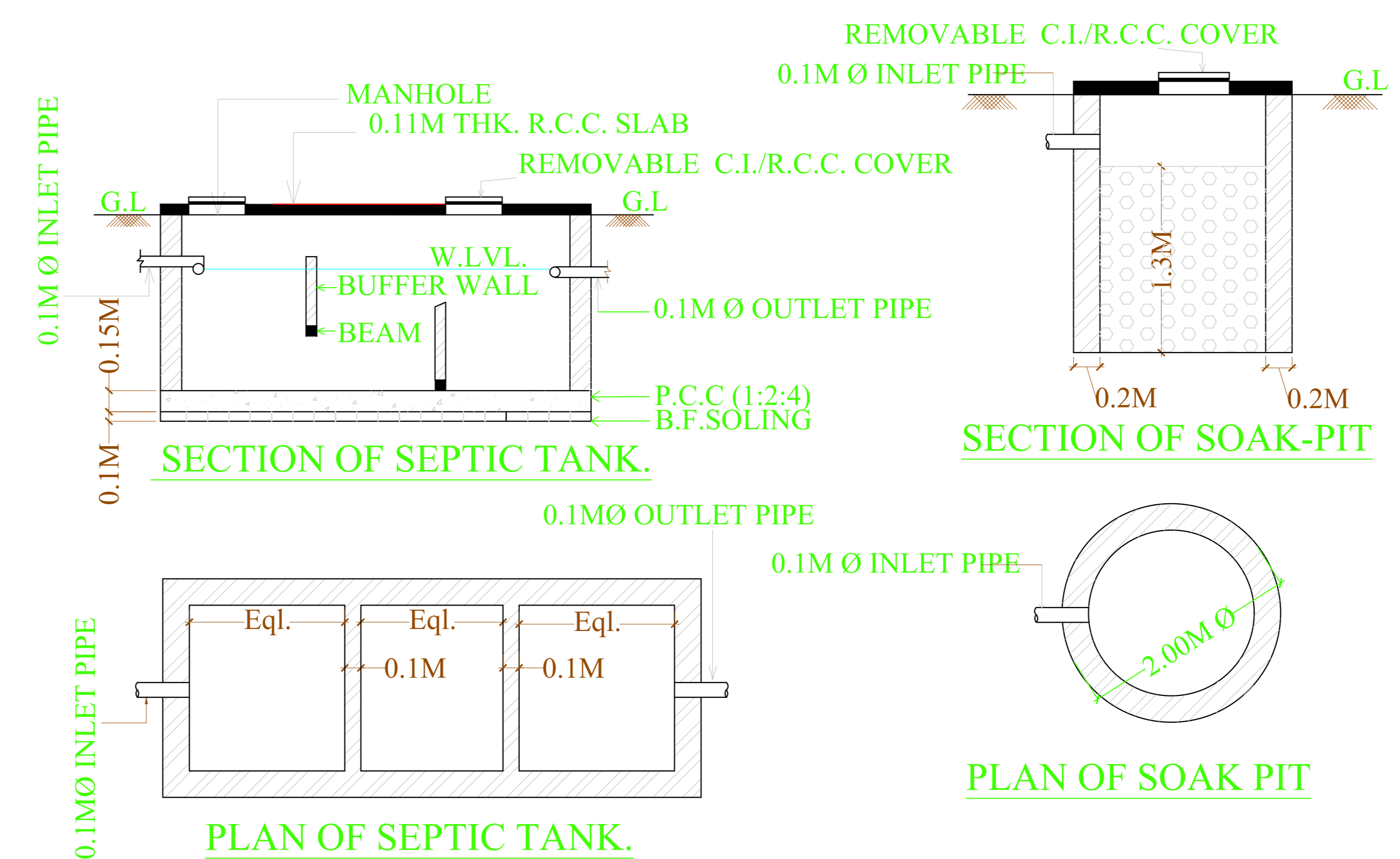

Proposal Basic Information	
Proposal File No.	JADA/BP/0017/2022
Owner Name	VIKASH KUMAR SHARMA, DIRECTOR M/S SUNDER ENTERPRISES
Khata No.	529
Plot No.	M-13 (SURVEY Plot No 43A)
Village Name	Dugri
Use	Industrial
SubUse	Industrial Building

AREA STATEMENT	
AREA OF PLOT (Minimum)	50 MT.
NET AREA OF PLOT (Gross Plot Area - Deduction from Gross Plot Area)	4042.58
Deduction for Balance Plot Area (from Gross Plot Area)	476.33
Common Plot	476.33
BALANCE AREA OF PLOT (Net Plot Area - Recreational/Amenity space)	3566.25
PLOT AREA FOR COVERAGE (Net Plot Area)	4042.58
Plot Area for FAR (Net Plot Area - Road/Watering Area)	4042.58

COVERAGE CHECK	
Permissible Coverage area (50.00 %)	2021.29
Proposed Coverage Area (47.19 %)	1907.77
Total Prop. Coverage Area (47.19 %)	1907.77
Balance coverage area (2.81 %)	113.52

FAR CHECK	
Perm. FAR Area (2.00)	8085.16
Total Perm. FAR area	8085.16
Industrial FAR	1907.77
Proposed FAR Area	1907.77
Total Proposed FAR Area	1907.77
Consumed FAR (Factor)	0.47
Balance FAR Area	6177.39

BUILT UP AREA CHECK	
Total Proposed BuiltUp Area	1907.77

ARCHITECT (Regd.)	
NAME	ALOK KUMAR GADIA

ENGINEER (Regd.)	
NAME	VIKASH KUMAR SHARMA, DIRECTOR M/S SUNDER ENTERPRISES.

SUPERVISOR (Regd.)	
NAME	VIKASH KUMAR SHARMA, DIRECTOR M/S SUNDER ENTERPRISES.

OWNER (Regd.)	
NAME	VIKASH KUMAR SHARMA, DIRECTOR M/S SUNDER ENTERPRISES.

DEVELOPMENT AUTHORITY	
NAME	LOCAL BODY

SCHEDULE OF DOOR:

NAME	LENGTH	HEIGHT	NOS
D	2.70	2.13	04

SCHEDULE OF WINDOW/VENTILATION:

NAME	LENGTH	HEIGHT	NOS
W1	3.92	2.70	04

Building -A (MS SUNDER ENTERPRISES)

Floor Name	Total Built Up Area (Sq.mt.)	Proposed FAR Area (Sq.mt.)	Total FAR Area (Sq.mt.)	Total Consumed Additional FAR Area (Sq.mt.)	Trent (No.)
Ground Floor	1907.77	1907.77	1907.77	1907.77	01
Total	1907.77	1907.77	1907.77	1907.77	01

UnitBUA Table for Building -A (MS SUNDER ENTERPRISES)

FLOOR	Name	UnitBUA Type	UnitBUA Area	Carpet Area	No. of Rooms	No. of Tenement
GROUND FLOOR PLAN	FACTORY	OTHER	1907.77	1907.77	1	1
Total	-	-	1907.77	1907.77	1	1

FAR & Tenement Details (Table 4c-1)

Building	No. of Same Bldg	Total Built Up Area (Sq.mt.)	Proposed FAR Area (Sq.mt.)	Total FAR Area (Sq.mt.)	Total Consumed Additional FAR Area (Sq.mt.)	Trent (No.)
A (MS SUNDER ENTERPRISES)	1	1907.77	1907.77	1907.77	1907.77	01
Grand Total	1	1907.77	1907.77	1907.77	1907.77	01

Building USE/SUBUSE Details

Building Name	Building Use	Building SubUse	Building Structure
A (MS SUNDER ENTERPRISES)	Industrial	Industrial Building	Non-Highrise

Buildingwise Floor FAR Details

Floor Name	Building Name	Proposed Built Up Area (Sq.mt.)	Proposed FAR Area (Sq.mt.)	Total Proposed Built Up Area (Sq.mt.)	Total FAR Area (Sq.mt.)
Ground Floor	A (MS SUNDER ENTERPRISES)	1907.77	1907.77	1907.77	1907.77
Total	-	1907.77	1907.77	1907.77	1907.77

Required Parking (Table 7a)

Building Name	Type	SubUse	Area (Sq.mt.)	Units	Car	Visitors Car	Tech/Healer
A (MS SUNDER ENTERPRISES)	Industrial	Industrial Building	>0	400	1907.77	1	4
Total	-	-	>0	400	1907.77	1	4

Parking Check (Table 7b)

Vehicle Type	No.	Area	No.	Area
Total Car	4	50.00	9	112.50
Visitor's Car Parking	-	-	1	12.50
Total Visitor Parking	-	-	1	12.50
Tech/Healer	-	-	69	138.00
Total Tech/Healer	10	20.00	69	138.00
Total	14	70.00	79	401.00

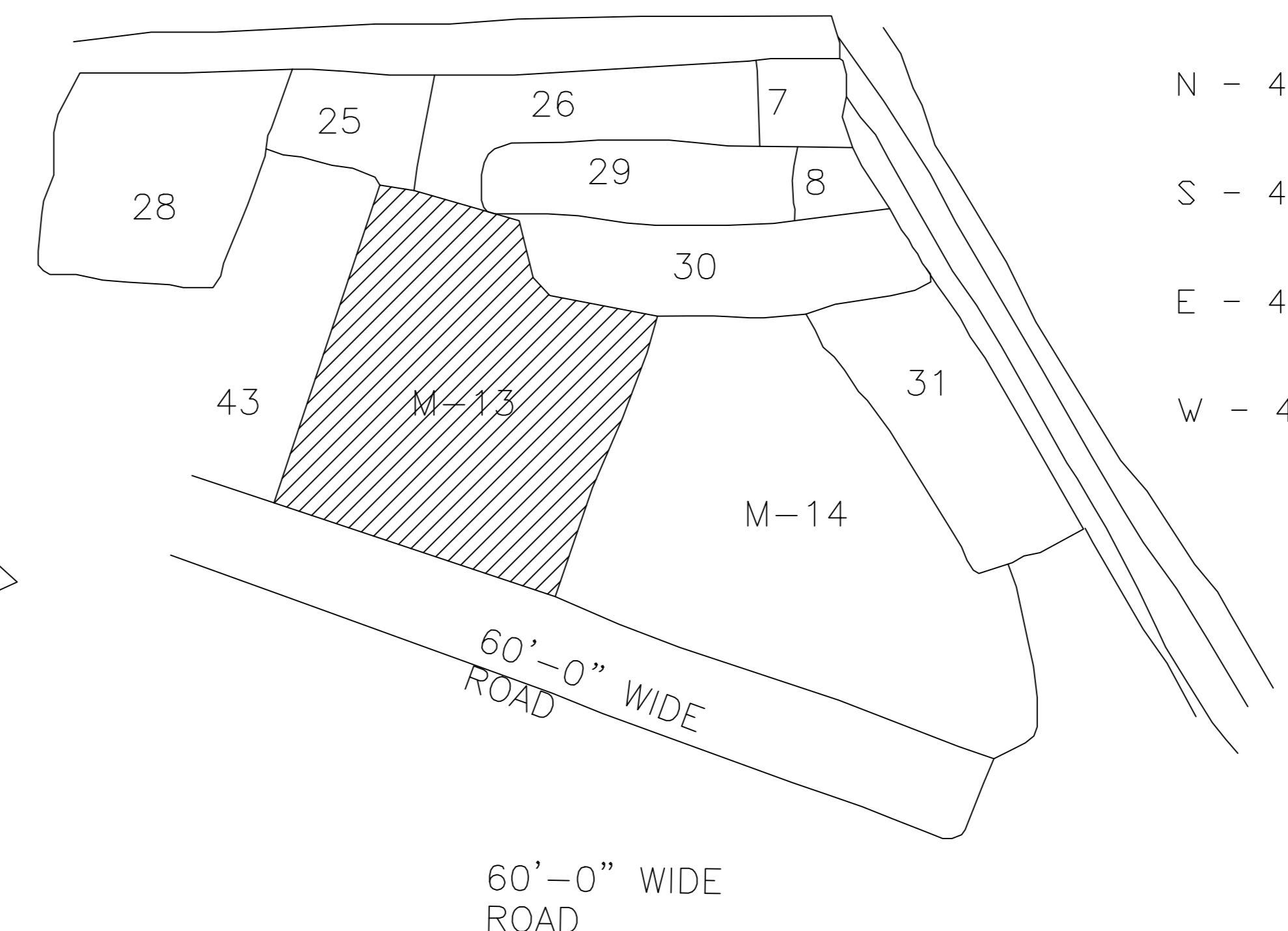

N - 43(P), 25, 26, 29, 30 - JIADA BOUNDARY
S - 43(P), - 60'-0" WIDE ROAD
E - 43(P), 30 - M-14
W - 43(P) - JIADA LAND

COLOR INDEX

FLAT BOUNDARY	Red
ABUTTING ROAD	Green
PROPOSED CONSTRUCTION	Yellow
COMMON PLOT	Blue
ROAD WIDENING AREA	Orange
EXISTING (To be retained)	Black
EXISTING (To be demolished)	White

SITE PLAN

Proposal Basic Information	
Proposal File No.	JADA/BP/00172022
Owner Name	VIKASH KUMAR SHARMA, DIRECTOR M/S SUNDER ENTERPRISES
Khata No	529
Plot No	M-13 (SURVEY Plot No 431A)
Village Name	Dugri
Use	Industrial
SubUse	Industrial Building

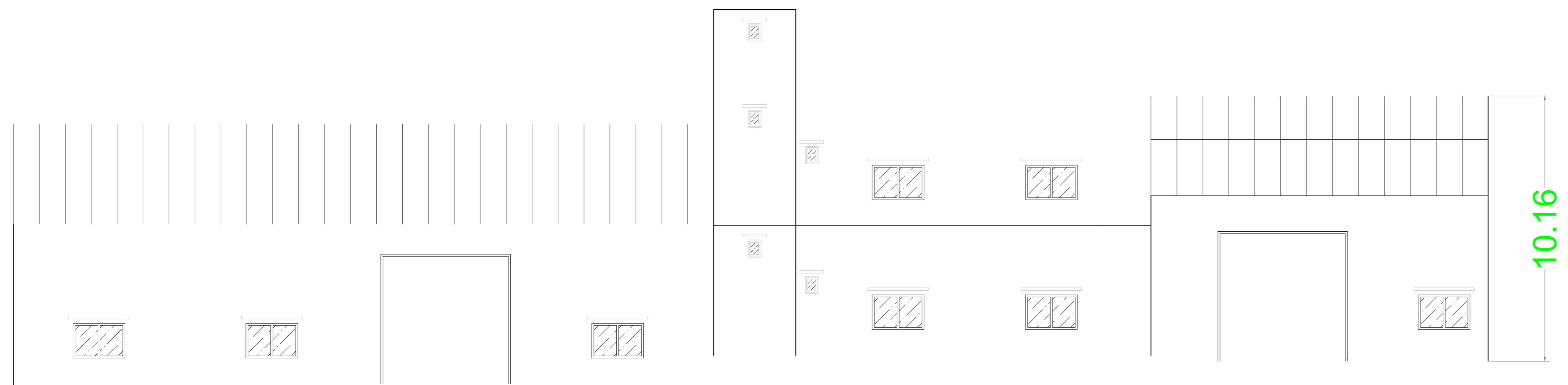

ELEVATION

75x75x6 ANGLE PURLINS & CLEAT

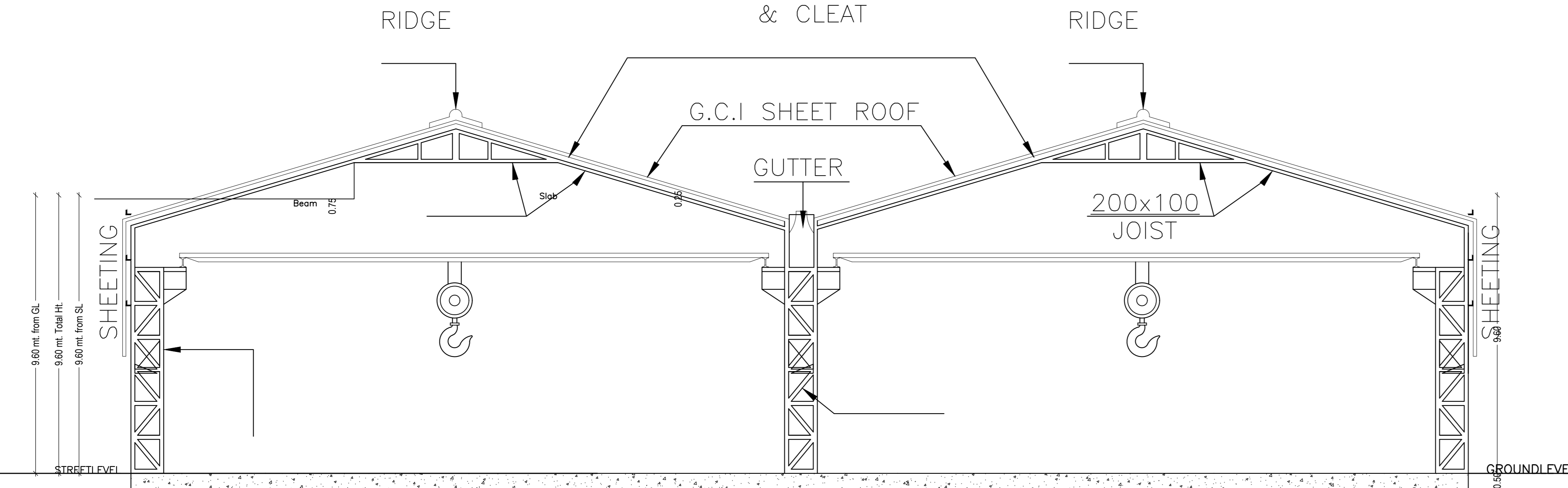

SECTION ON : X-Y

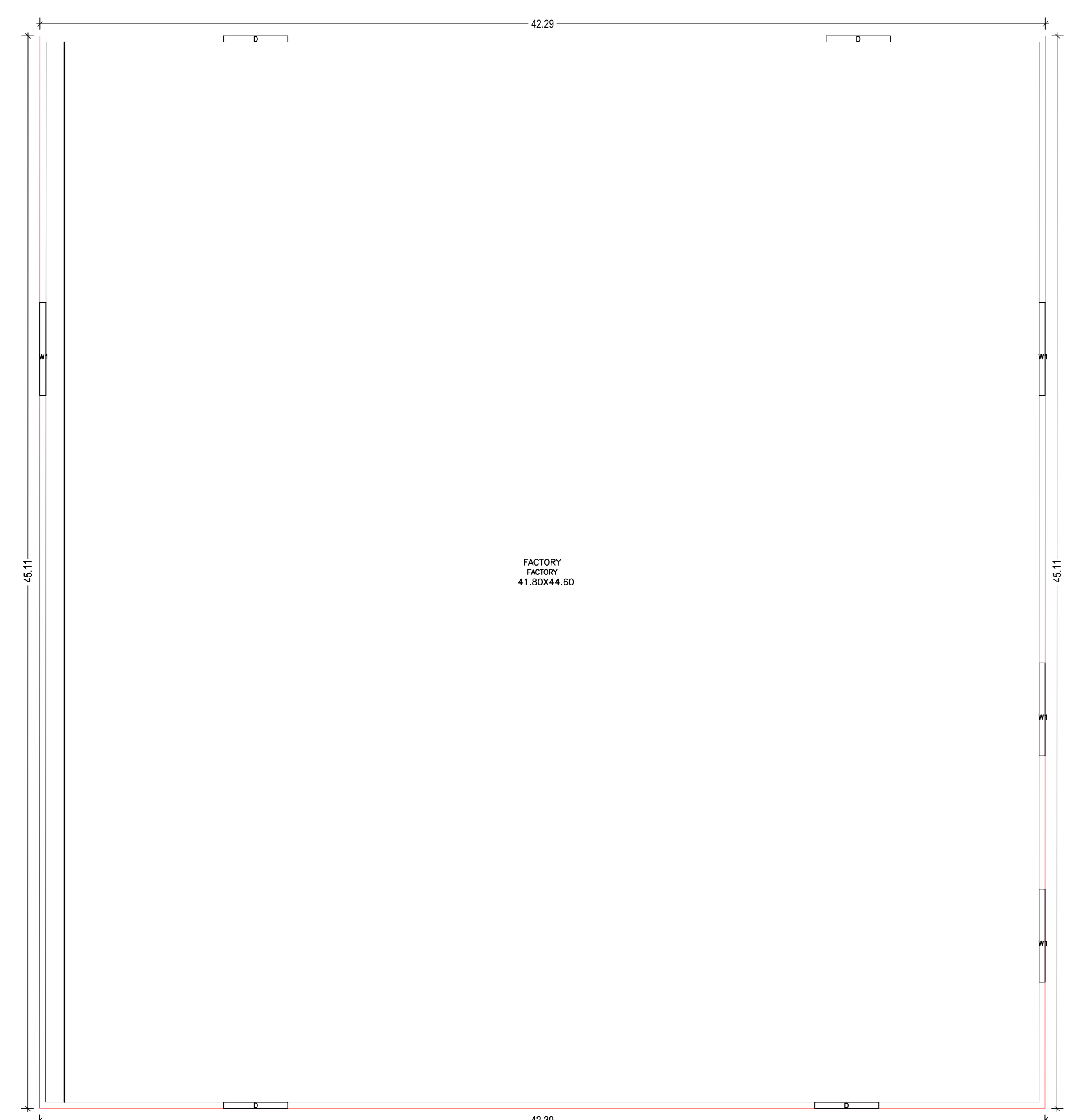

GROUND FLOOR PLAN (Proposed)

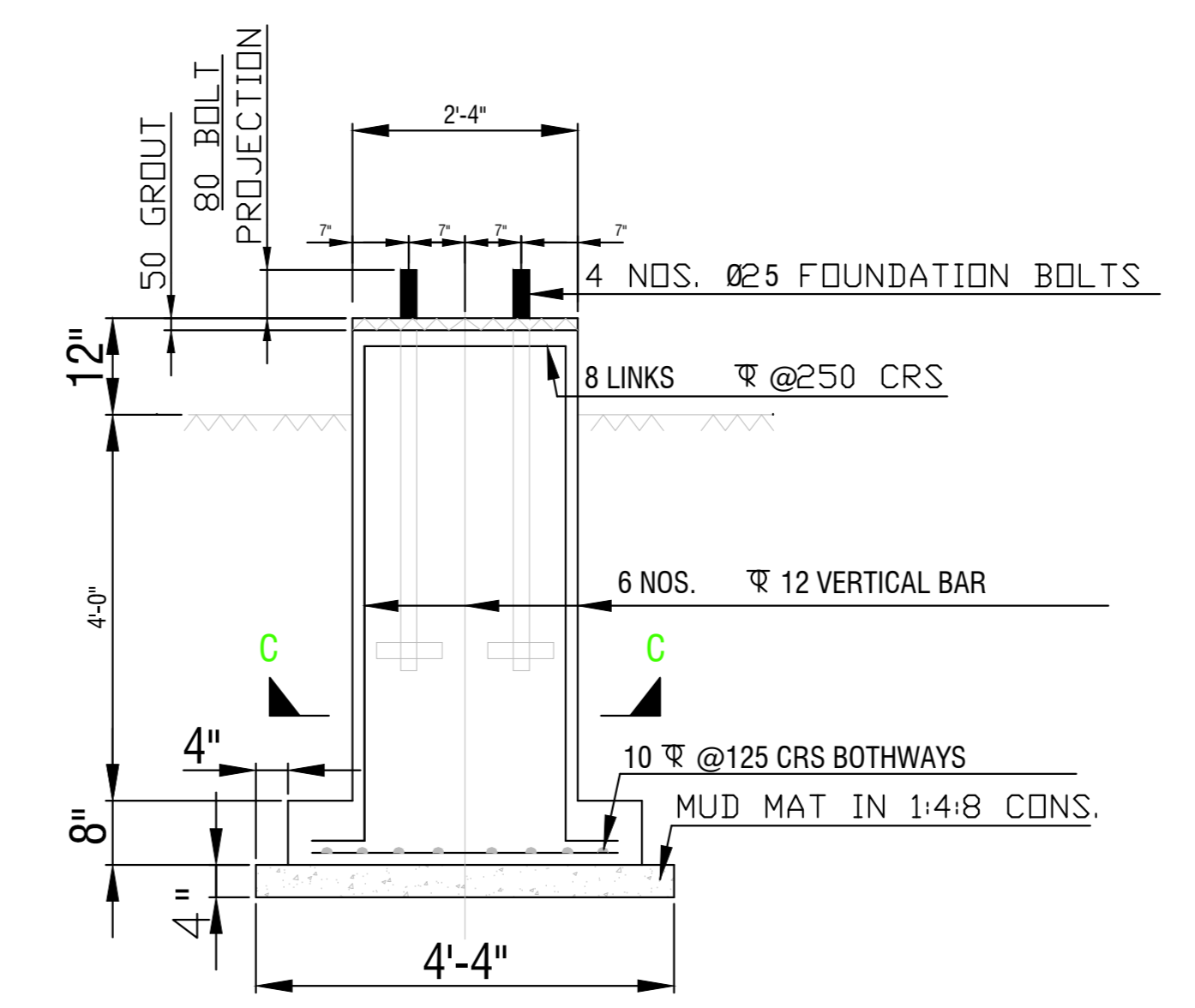
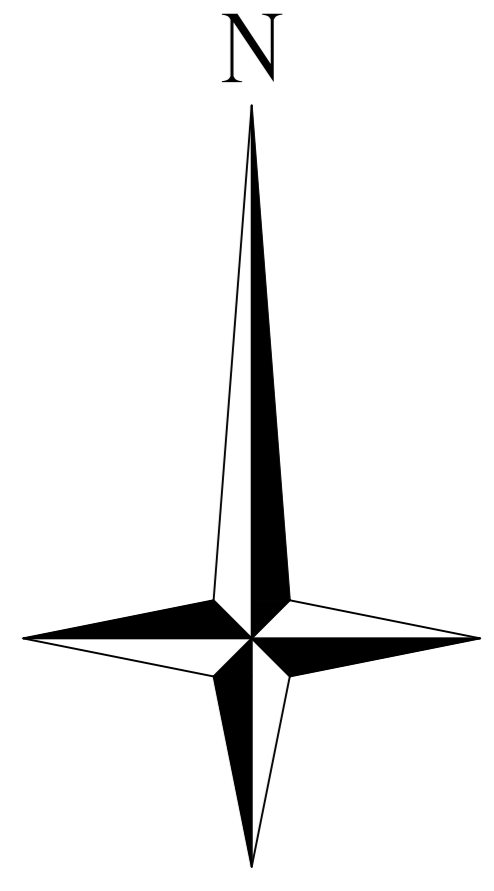
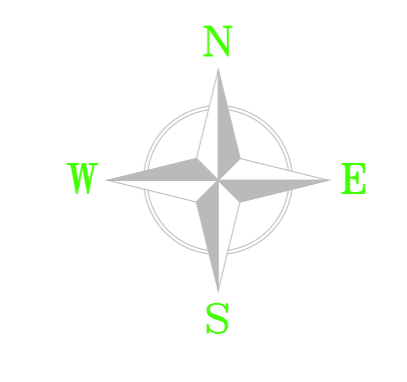
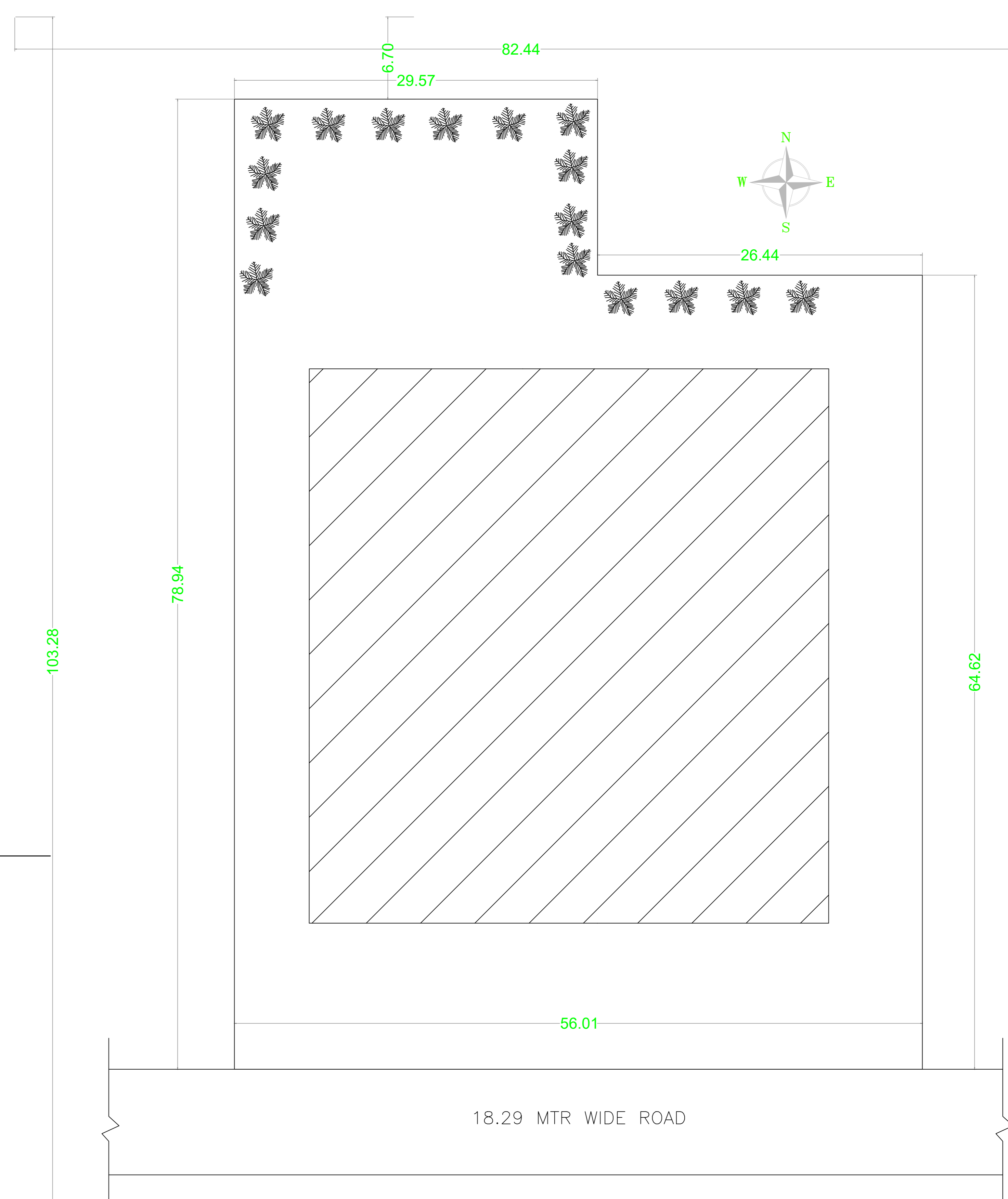

DETAIL OF COLUMN FOUNDATION

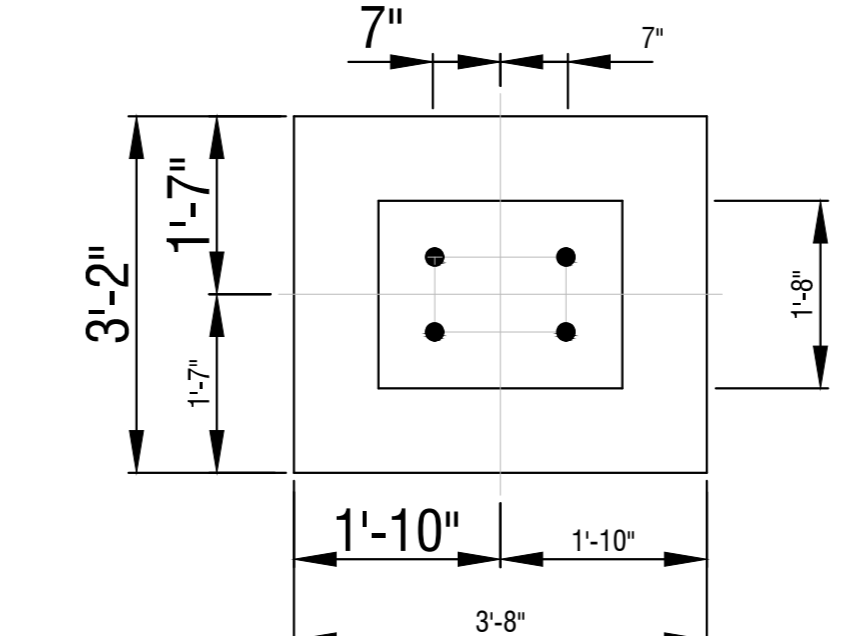

SECTION ON: C-C

LTP NAME AND SIGNATURE	STRUCTURAL ENGS NAME AND SIGNATURE	BUILDER NAME AND SIGNATURE	DIGITAL SIGNATURE
ALOK KUMAR GADIA JADA/ENG/0016/2021			