

Project Title :M/S VANSHIKA ENTERPRISES

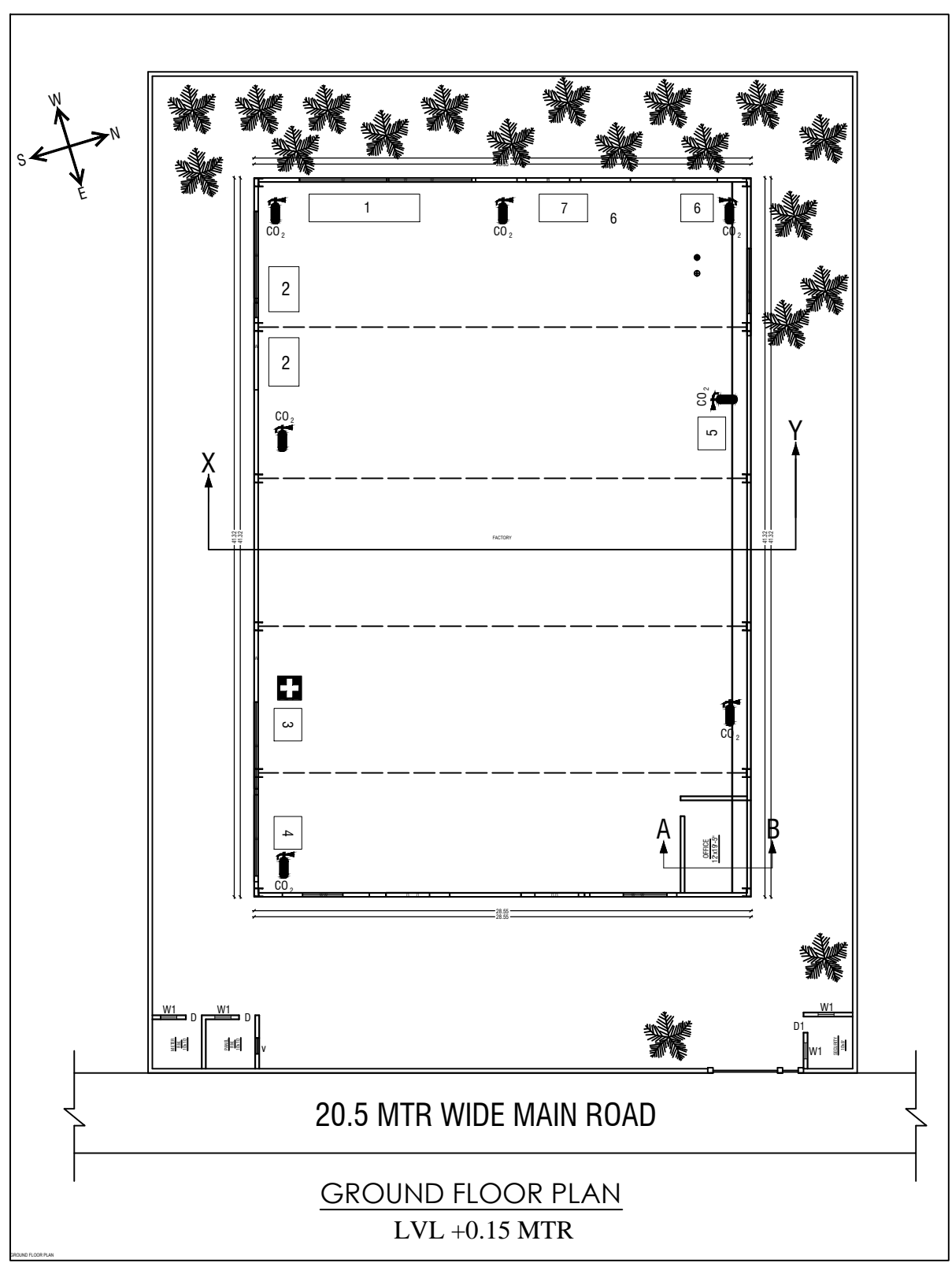
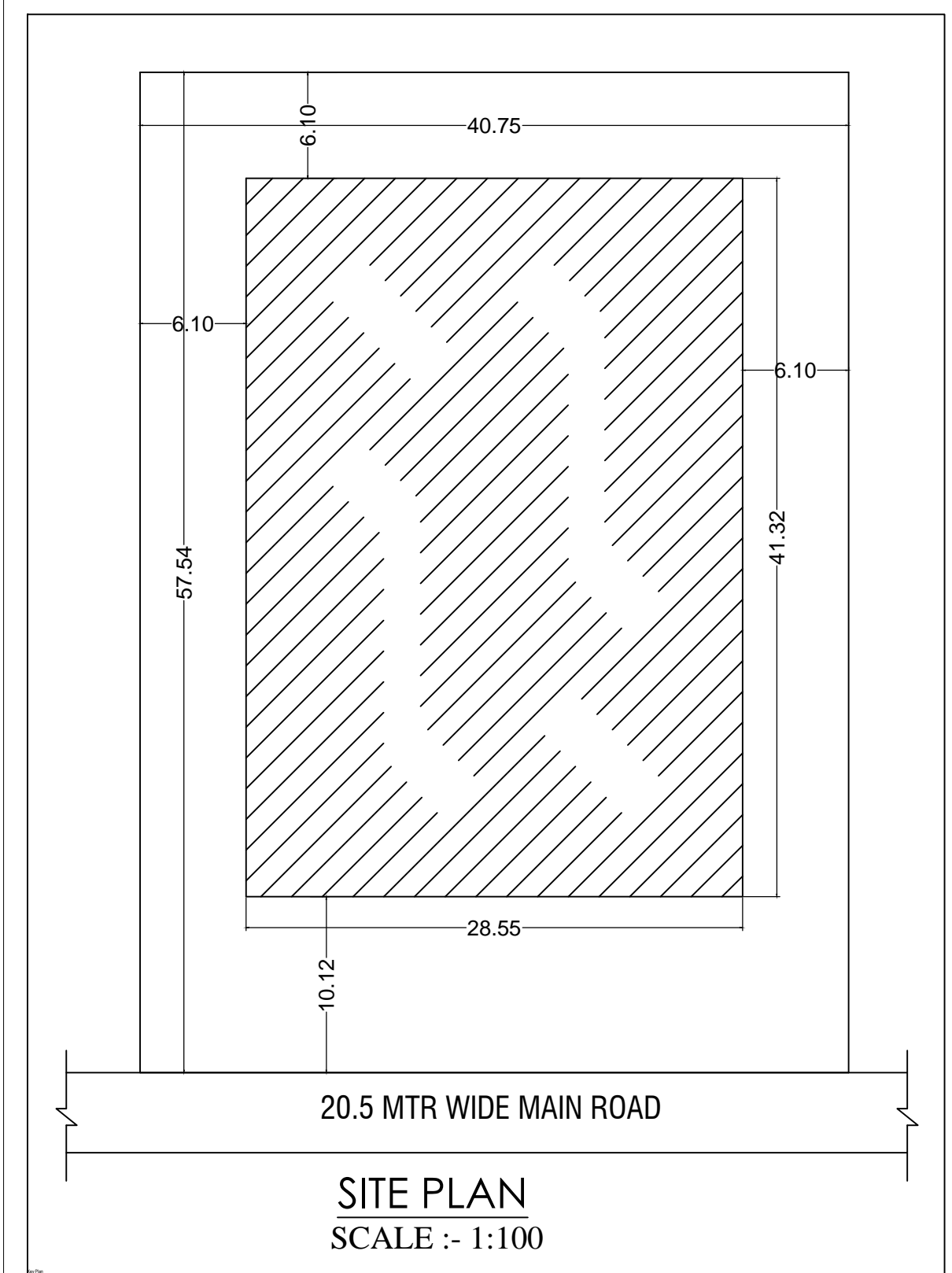
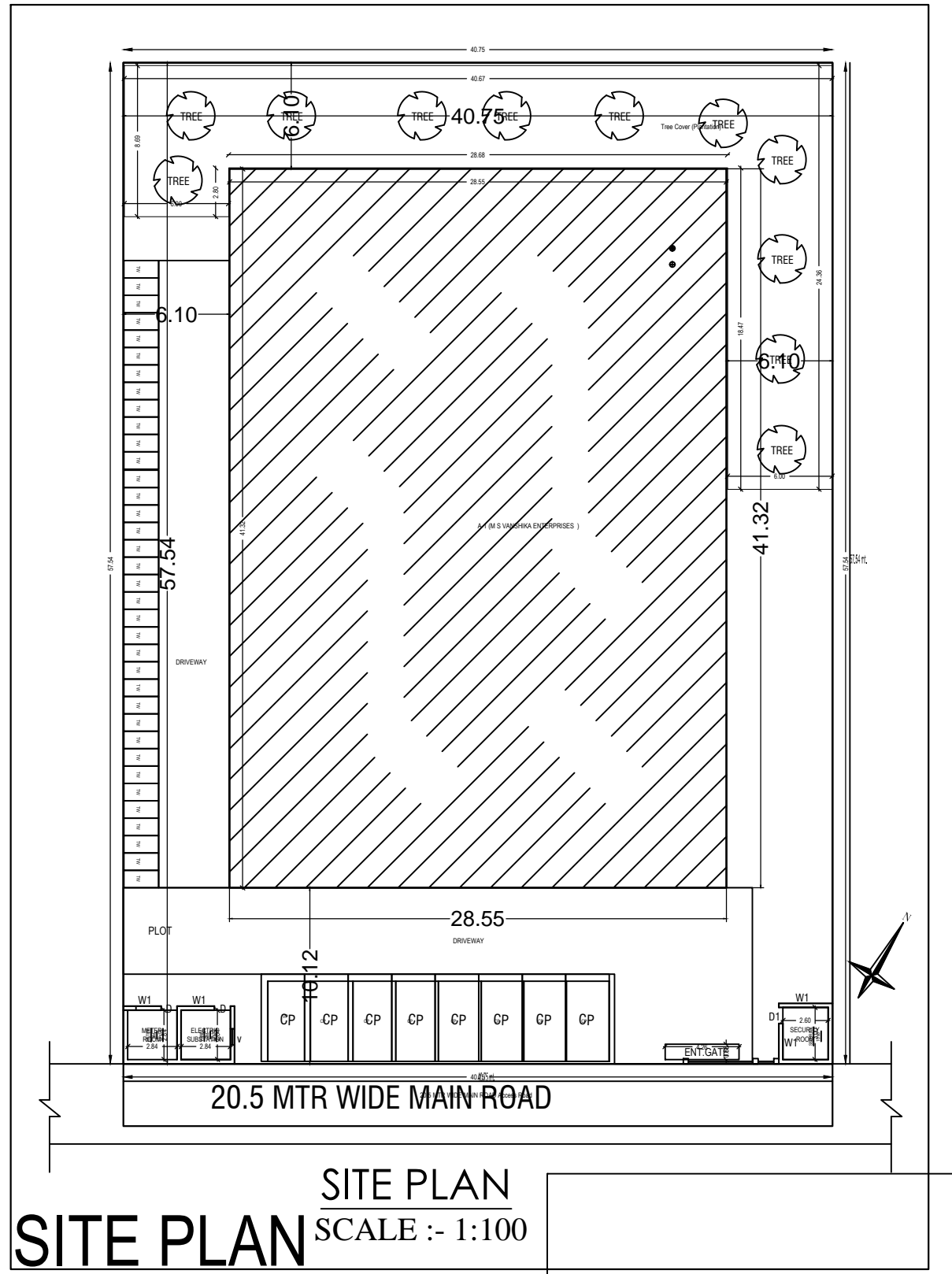
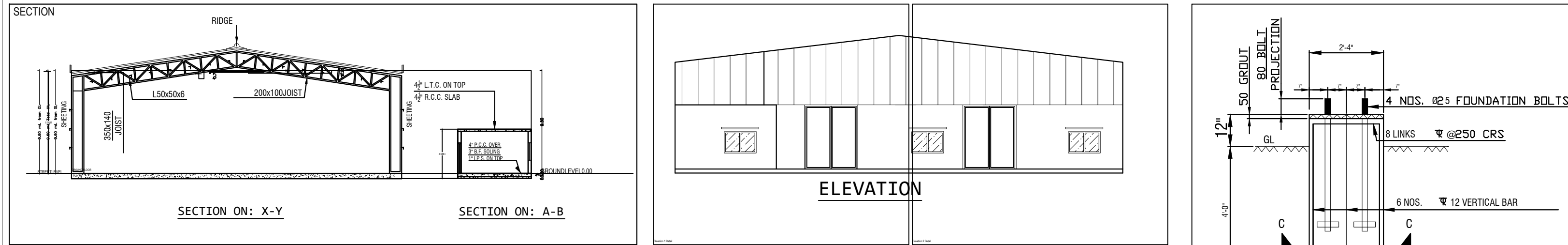
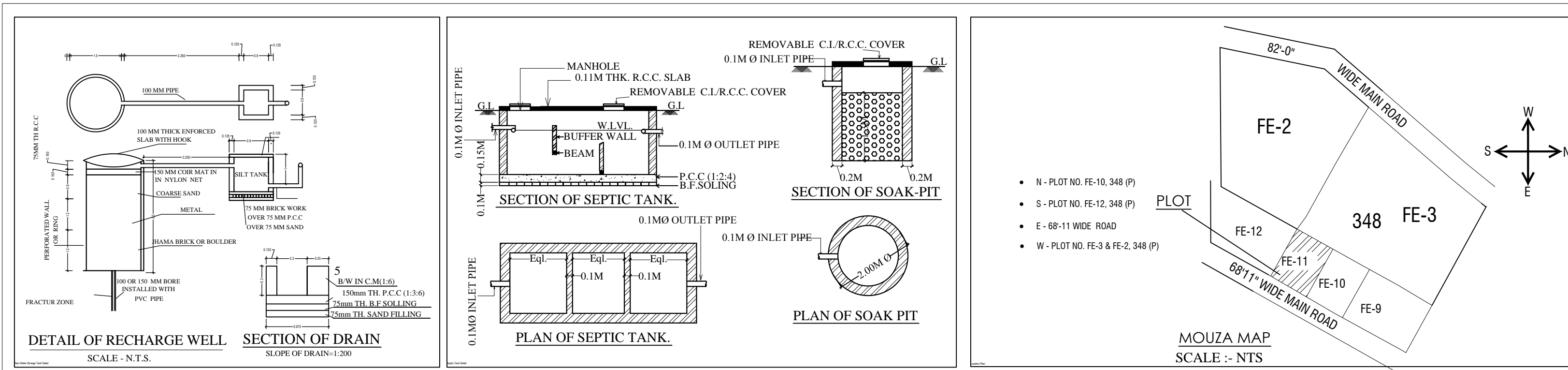

PROPOSED INDUSTRIAL PLAN FOR :-

LAND OWNER
M/S VANSHIKA ENTERPRISES
REPRESENTATIVE BY
KRISHNA KUMAR SHARMA
SIGNATURE

PLOT NO :- FE-11, SURVEY PLOT NO- 348 (P)
KATHA NO :- 81
MOUZA- HATHIADIH
THANA NO :- 60
THANA :-SARAIKELLA
DISTRICT :- SERAIKELLA- KHARSAWAN
STATE :- JHARKHAND

PLANNER	TITLE:- GROUND FLOOR PLAN MOUZA MAP SITE PLAN FRONT ELEVATION SIDE ELEVATION SECTIONAL VIEW	SH .NO- 1/1
---------	---	----------------

MATERIALS TO BE USED (AS PER SPECIFICATION)	
Sl. No.	Description
1	Concrete
2	Brick
3	Steel
4	Other
MATERIALS TO BE USED (AS PER SPECIFICATION)	
Sl. No.	Description
1	Concrete
2	Brick
3	Steel
4	Other

MATERIALS TO BE USED (AS PER SPECIFICATION)	
Sl. No.	Description
1	Concrete
2	Brick
3	Steel
4	Other
MATERIALS TO BE USED (AS PER SPECIFICATION)	
Sl. No.	Description
1	Concrete
2	Brick
3	Steel
4	Other