

TYP DETAIL OF FOOTING

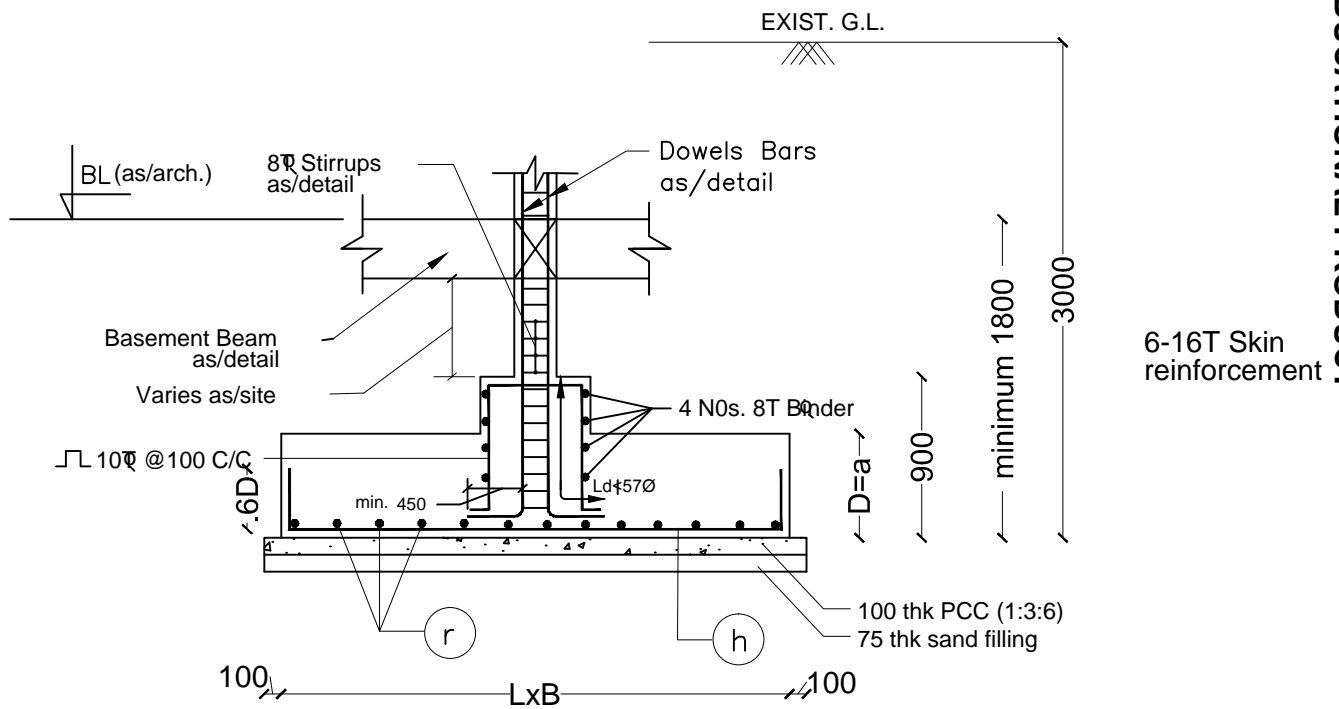

SECTION X-X

Structure Detail