

Proposal Basic Information

Proposal File No.	JADA/BP/0002/2024
Owner Name	M/S AMIT ENTERPRISES REPRESENTED BY AMIT KEJRIWAL
Khata No.	155
Plot No.	SURVEY PLOT NO. 1253P INDUSTRIAL PLOT NO. 7P
Village Name	Saher
Use	Industrial
SubUse	Industrial Building

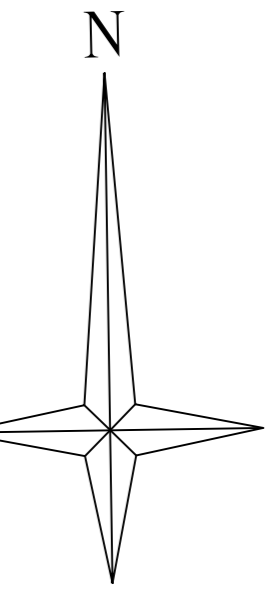

AREA STATEMENT	VERSION NO. : 1.0.70
JHARKHAND INDUSTRIAL AREA DEVELOPMENT AUTHORITY	VERSION DATE: 16/10/2020
PROJECT DETAIL:	
Region: JHARKHAND URBAN LOCAL BODIES	Plot Use: Industrial
District: RANCHI	Plot SubUse: Industrial Building
Authority: JHARKHAND INDUSTRIAL AREA DEVELOPMENT AUTHORITY	Plot/Neary/Religious/Structure: NA
Inward No. JADA/BP/0002/2024	Plot/SubPlot No. SURVEY PLOT NO. 1253P INDUSTRIAL PLOT NO. 7P
Application Type: General Proposal	North Plot No. -
Project Type: Building Permission	South Plot No. -
Nature of Development: New	East Plot No. -
Location of Development Area: New Area	West Road Width - 15.2
AREA DETAILS:	
AREA OF PLOT (Minimum)	(A)
NET AREA OF PLOT (Gross Plot Area - Deduction from Gross Plot Area)	(A-Deductions)
Deduction for Balance Plot Area (from Gross Plot Area)	
Common Plot	500.05
BALANCE AREA OF PLOT (Net Plot Area - Recreational/Amenity Space)	(A-Deductions)
FLOT AREA FOR COVERAGE (Net Plot Area)	(A-Deductions)
Plot Area for FAR (Net Plot Area + Road/Widening Area)	(A-Deductions)
COVERAGE CHECK	
Permissible Coverage Area (50.00%)	2499.28
Proposed Coverage Area (50.00%)	2499.18
Total Prop. Coverage Area (50%)	2499.18
Balance coverage area (%)	0.10
FAR CHECK	
Perm. FAR Area (2.00)	9979.12
Total Perm. FAR Area	9979.12
Industrial FAR	5978.71
Proposed FAR Area	5978.71
Total Proposed FAR Area	5978.71
Consumed FAR (Factor)	1.25
Balance FAR Area	4018.41
BUILT UP AREA CHECK	
Total Proposed BuiltUp Area	5978.72
ARCHITECT (Regd)	ZIA UR RAHMAN
ENGINEER (Regd)	
SUPERVISOR (Regd)	
OWNER (Regd)	M/S AMIT ENTERPRISES REPRESENTED BY AMIT KEJRIWAL
DEVELOPMENT AUTHORITY	LOCAL BODY

Required Parking (Table 7a)

Building Name	Type	SubUse	Area (Sq.mt)	Units	Car	Two Wheeler
A (FACTORY)	Industrial	Industrial	> 400	5978.71	1	10
A (FACTORY)	Industrial	Industrial	> 400	5978.71	-	1
Total:					10	10

Parking Check (Table 7b)

Vehicle Type	No.	Area	Prop.	Area
Car	10	125.00	10	125.00
Two Wheeler	32	64.00	33	66.00
Total	42	189.00	43	191.00

Buildingwise Floor FAR Details

Floor Name	Building Name		Total	
	Proposed Built Up Area (Sq. mt.)	Proposed FAR Area (Sq. mt.)	Total Proposed Built Up Area (Sq. mt.)	Total FAR Area (Sq. mt.)
A (FACTORY)				
Basement Floor	2699.48	2699.48	2699.48	2699.48
Ground Floor	2499.18	2499.18	2499.18	2499.18
First Floor	390.03	390.03	390.03	390.03
Second Floor	390.03	390.03	390.03	390.03
Terrace Floor	0.00	0.00	0.00	0.00
Total:	5978.72	5978.72	5978.72	5978.72

FAR & Tenement Details (Table 4c-1)

Building	No. of Same Bldg	Total Built Up Area (Sq.mt.)	Proposed FAR Area (Sq.mt.)	Total FAR Area (Sq.mt.)	Total Consumed Additional FAR Area (Sq.mt.)	Tnmt (No.)
A (FACTORY)	1	5978.72	5978.71	5978.72	5978.72	04
Grand Total:	1	5978.72	5978.71	5978.72	5978.72	04

Building USE/SUBUSE Details

Building Name	Building Use	Building SubUse	Building Structure
A (FACTORY)	Industrial	Industrial Building	Non-Highrise

COLOR INDEX

FLAT BOUNDARY	Green
ABUTTING ROAD	Red
PROPOSED CONSTRUCTION COMMON PLOT	Blue
ROAD WIDENING AREA	Yellow
EXISTING (To be retained)	Orange
EXISTING (To be demolished)	Purple

15.24 METER WIDE ROAD
50' WIDE ROAD

PLOT AREA= 4998.48 SQMT
G.C. = 2499.17 SQMT

PRO-SITE PLAN

Proposal Basic Information	
Proposal File No.	JADA/BP/0002/2024
Owner Name	M/S AMT ENTERPRISES REPRESENTED BY AMT KILIRIWA
Khata No.	155
Plot No.	SURVEY PLOT NO. 1253P INDUSTRIAL PLOT NO.-7P
Village Name	Sahr
Use	Industrial
SubUse	Industrial Building

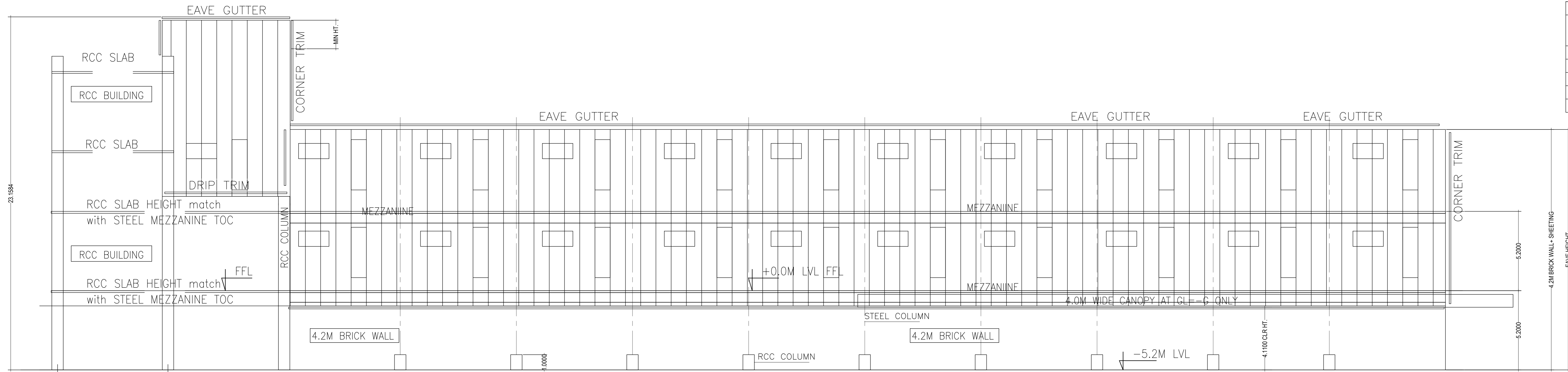

SIDE ELEVATION

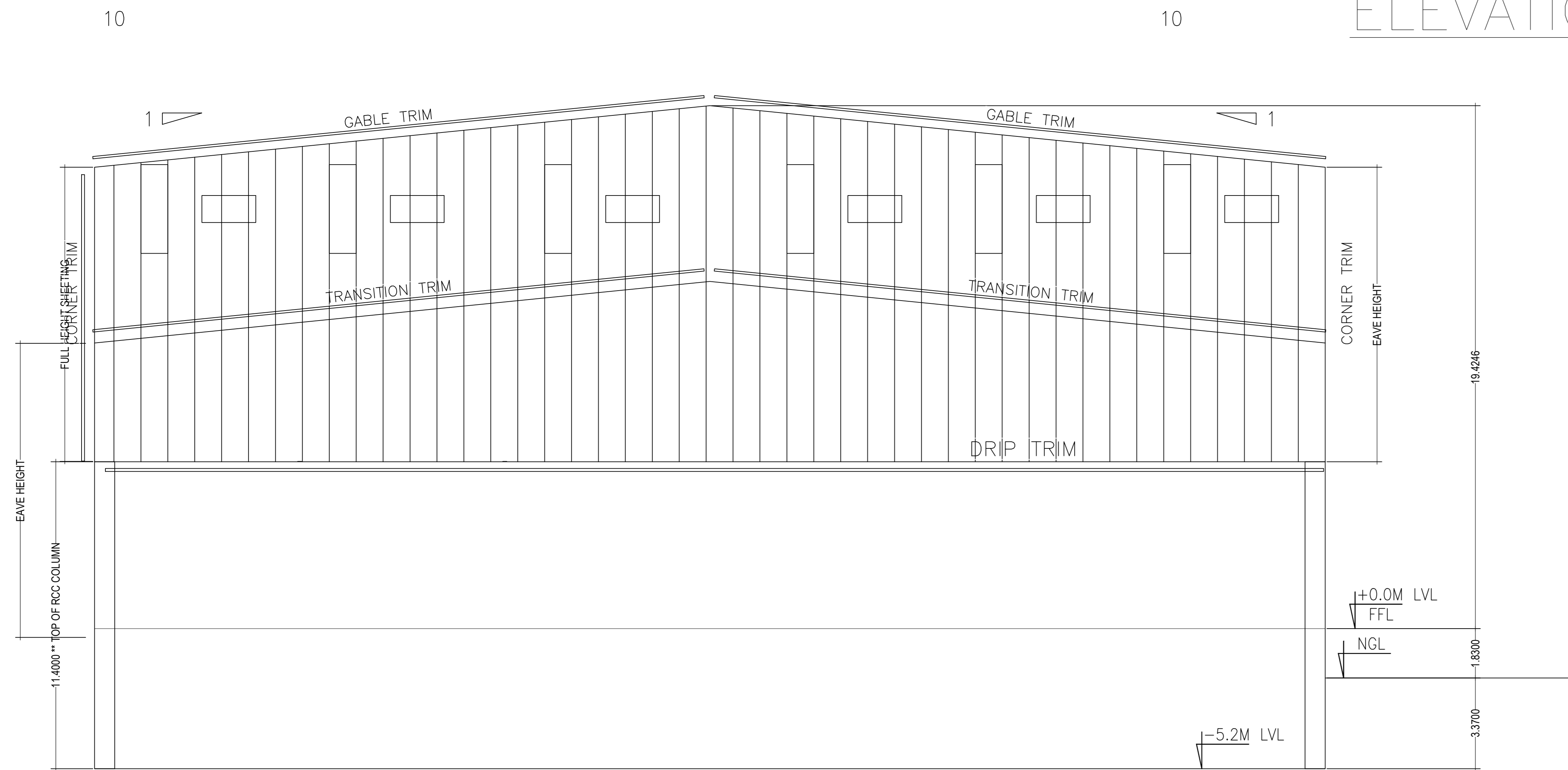

FRONT ELEVATION

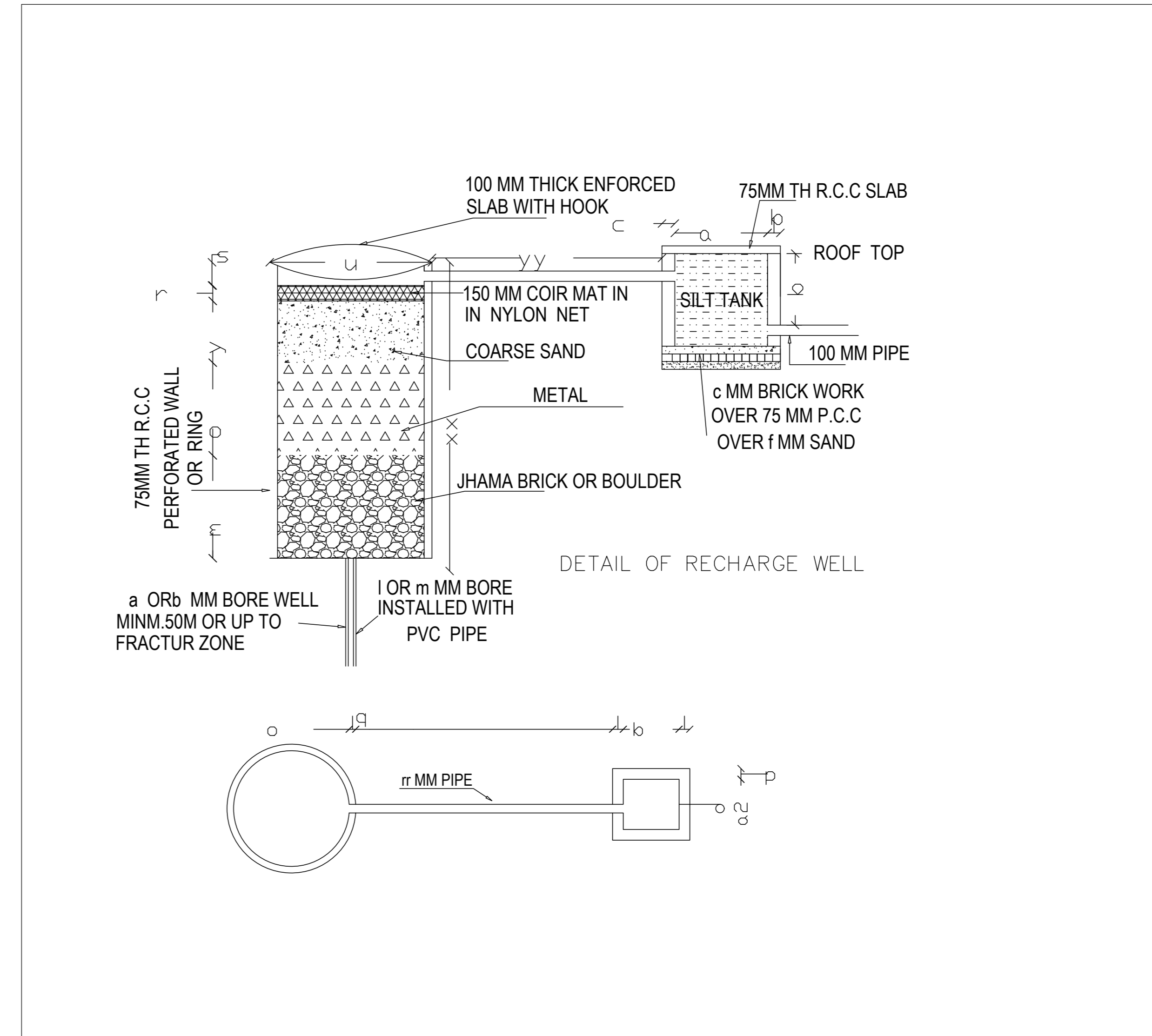

Building :A (FACTORY)

Floor Name	Total Built Up Area (Sq.m)	Proposed FAR Area (Sq.m)	Total FAR Area (Sq.m)	Total Consumed Additional FAR Area (Sq.m)	Trent (No.)
Basement Floor	2699.48	2699.48	2699.48	2699.48	01
Ground Floor	2499.18	2499.18	2499.18	2499.18	01
First Floor	390.03	390.03	390.03	390.03	01
Second Floor	390.03	390.03	390.03	390.03	01
Terrace Floor	0.00	0.00	0.00	0.00	00
Total	5978.72	5978.71	5978.72	5978.72	04
Total Number of Same Building	1				
Total	5978.72	5978.71	5978.72	5978.72	04

SCHEDULE OF DOOR:

BUILDING NAME	NAME	LENGTH	HEIGHT	NOS
A (FACTORY)	D	1.50	2.50	02
A (FACTORY)	D	6.87	2.50	02

SCHEDULE OF WINDOW/VENTILATION:

BUILDING NAME	NAME	LENGTH	HEIGHT	NOS
A (FACTORY)	MECH VENT	1.80	1.20	04

UnitBUA Table for Building :A (FACTORY)

FLOOR	Name	UnitBUA Type	UnitBUA Area	Carpet Area	No. of Rooms	No. of Tenement
BASMENT FLOOR PLAN	1	OTHER	2476.75	2475.22	1	1
GROUND FLOOR PLAN	2	OTHER	2475.73	2474.19	1	1
FIRST FLOOR PLAN	3	OTHER	390.03	388.21	1	1
SECOND FLOOR PLAN	4	OTHER	390.03	388.19	1	1
Total	-	-	5732.54	5725.81	4	4

LTP NAME AND SIGNATURE ZIA UR RAHMAN JADA/WC/0002/2018	STRUCTURAL ENGS NAME AND SIGNATURE	BUILDER NAME AND SIGNATURE	DIGITAL SIGNATURE
--	------------------------------------	----------------------------	-------------------

Proposal Basic Information	
Proposal File No.	JADA/BP/0002/2024
Owner Name	M/S AMIT ENTERPRISES REPRESENTED BY AMIT KUMAR
Khata No	155
Plot No	SURVEY PLOT NO. 1253P INDUSTRIAL PLOT NO-7P
Village Name	Sahar
Use	Industrial
SubUse	Industrial Building

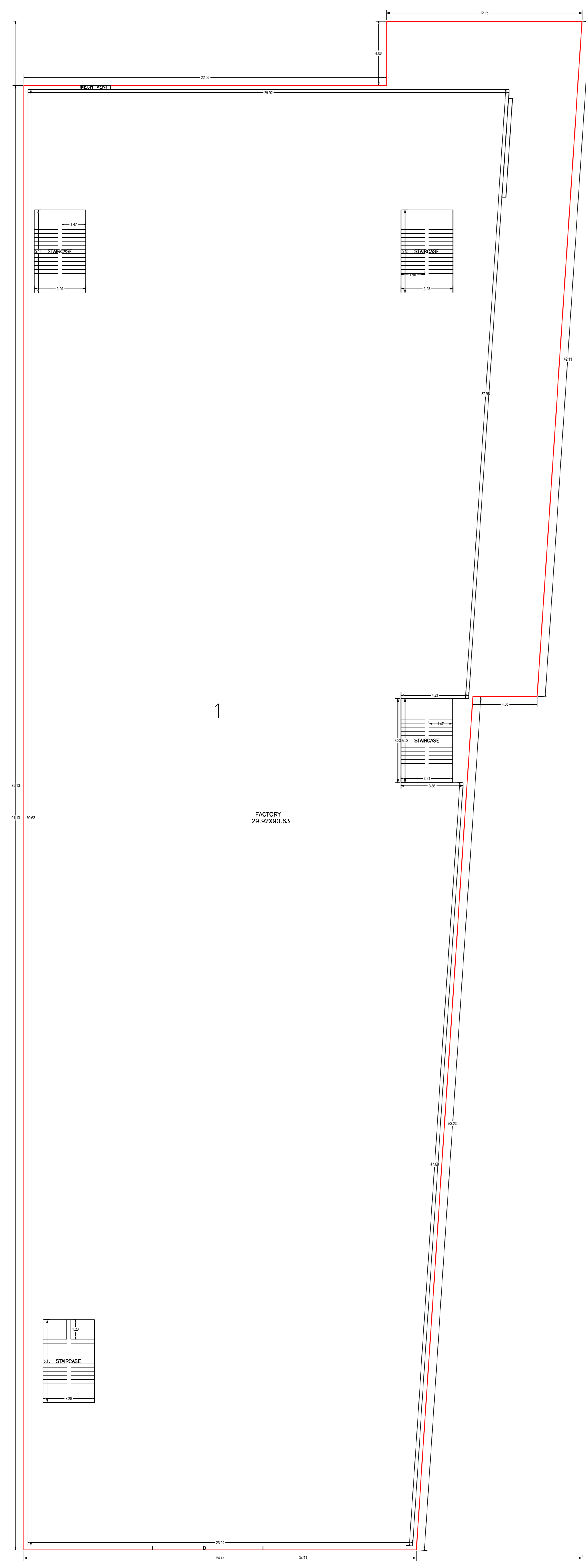
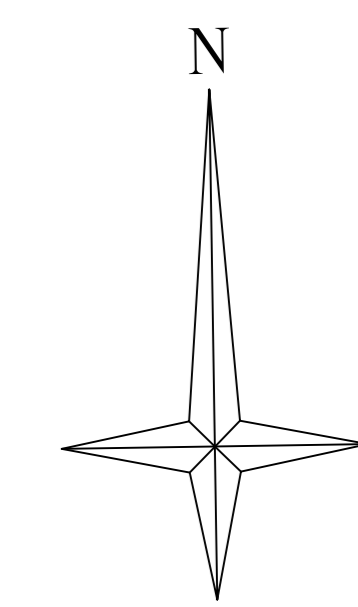

BASEMENT FLOOR PLAN (Proposed)

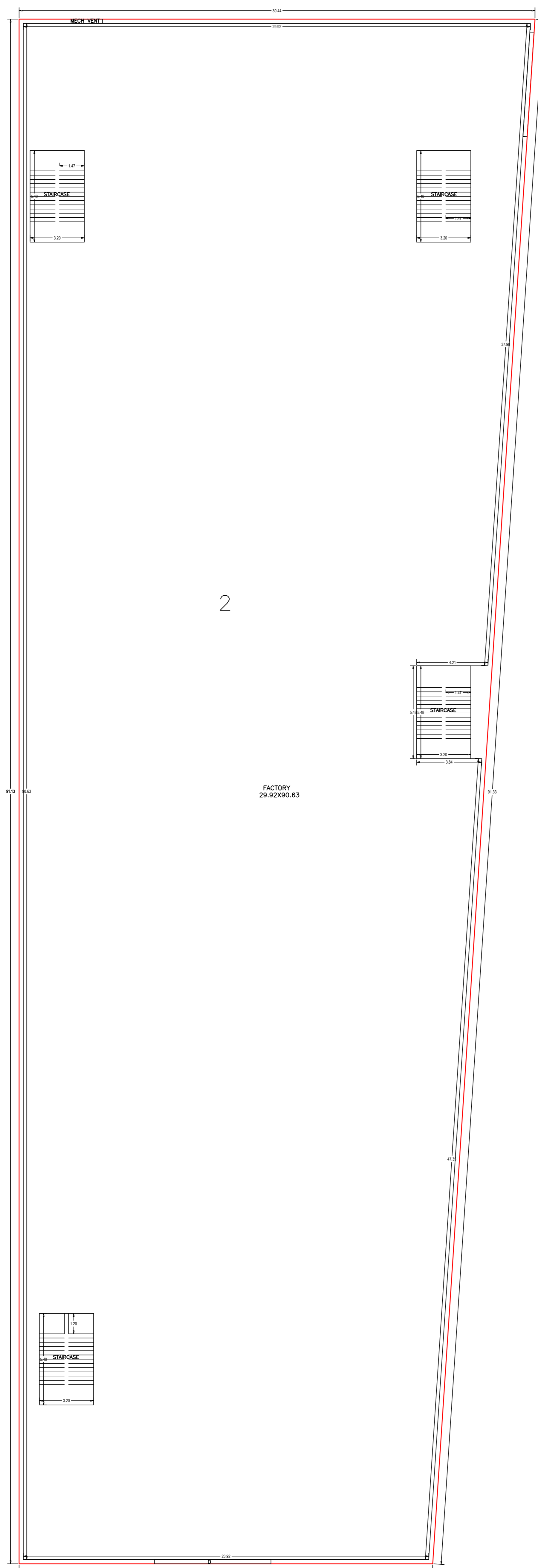

GROUND FLOOR PLAN (Proposed)

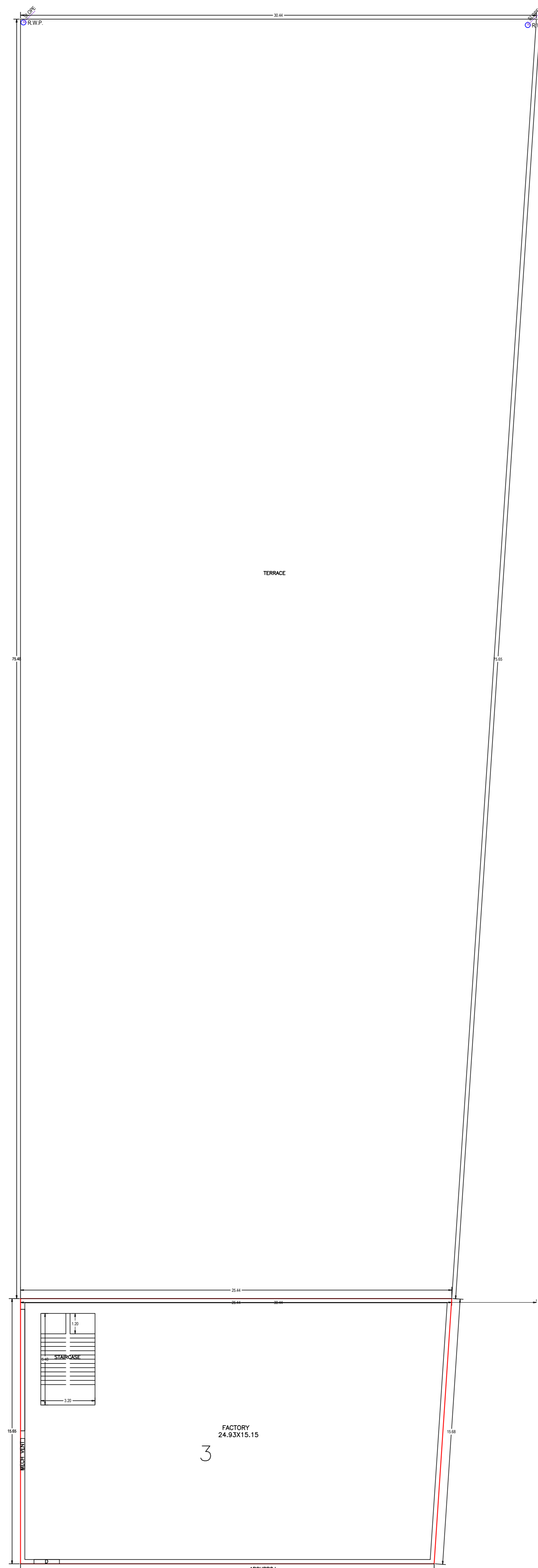

FIRST FLOOR PLAN (Proposed)

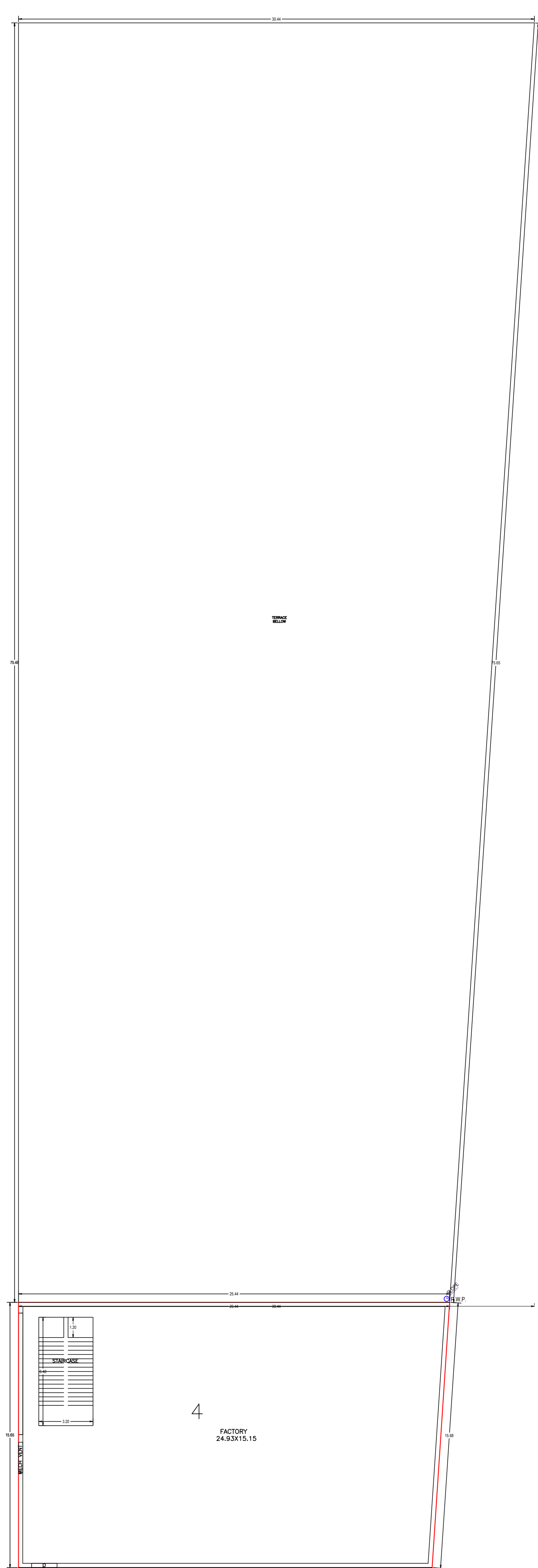

SECOND FLOOR PLAN (Proposed)

LTP NAME AND SIGNATURE	STRUCTURAL ENGS NAME AND SIGNATURE	BUILDER NAME AND SIGNATURE	DIGITAL SIGNATURE
ZIA UR RAHMAN JADA/NRC/0002/2018			

Proposal Basic Information	
Proposal File No.	JADA/BP/0002/2024
Owner Name	M/S AMIT ENTERPRISES REPRESENTED BY AMIT KULSHRWA
Khata No	155
Plot No	SURVEY PLOT NO. 1253P INDUSTRIAL PLOT NO-7P
Village Name	Saher
Use	Industrial
SubUse	Industrial Building

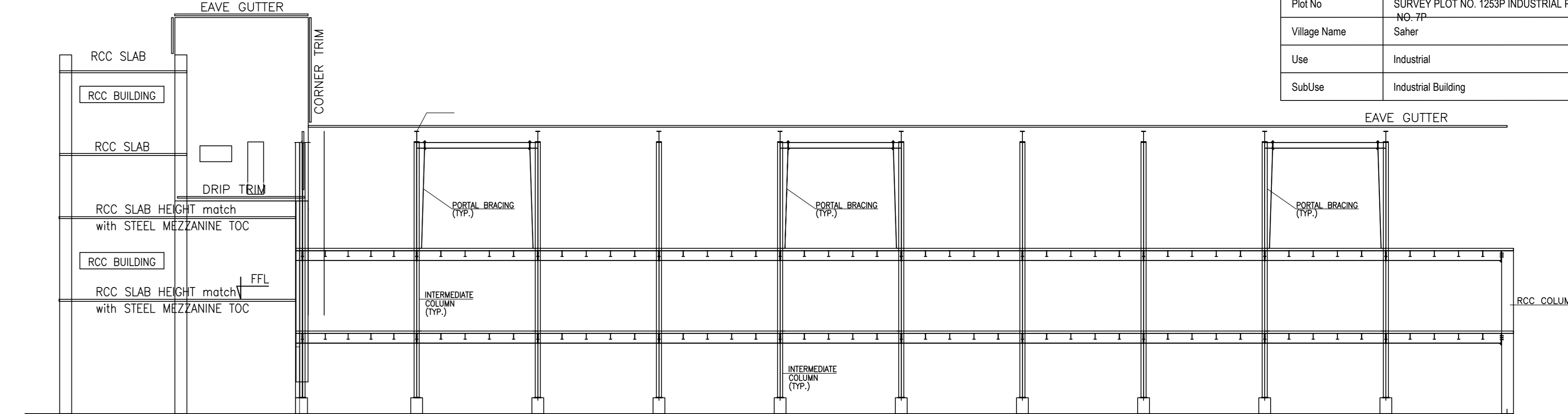
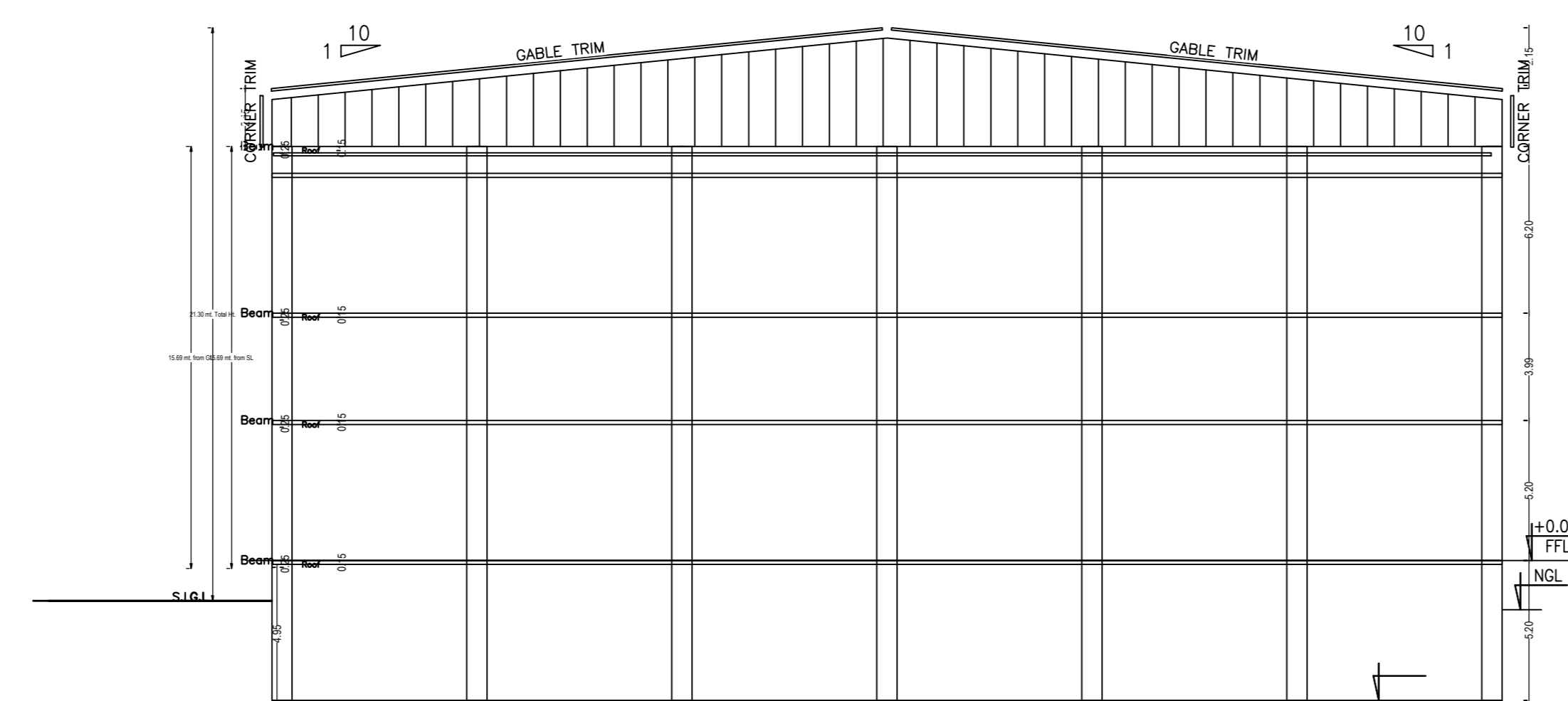
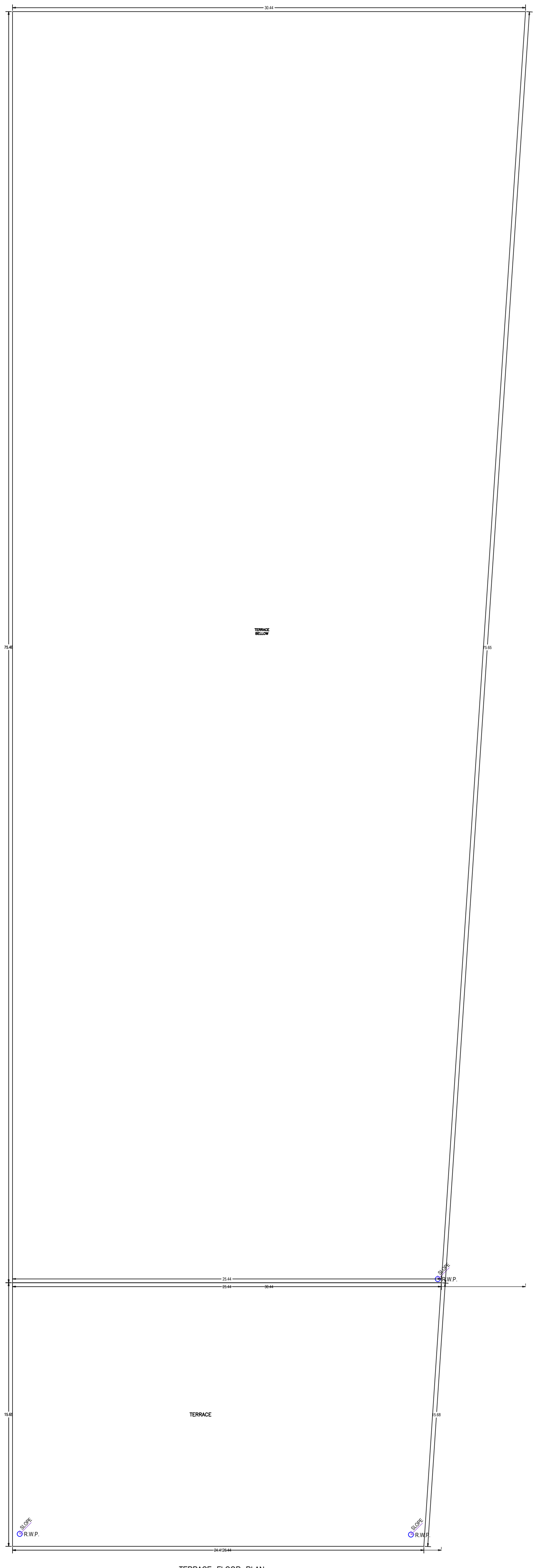

- SPECIFICATION OF DRAIN**
- FOUNDATION.
 - SAND FILLING.
 - BRICK SOLLING.
 - P.C.C (1:4:8).
 - B/W IN C.M (1:6)..
 - R.C.C (1:1.5:3) COVER SLAB.

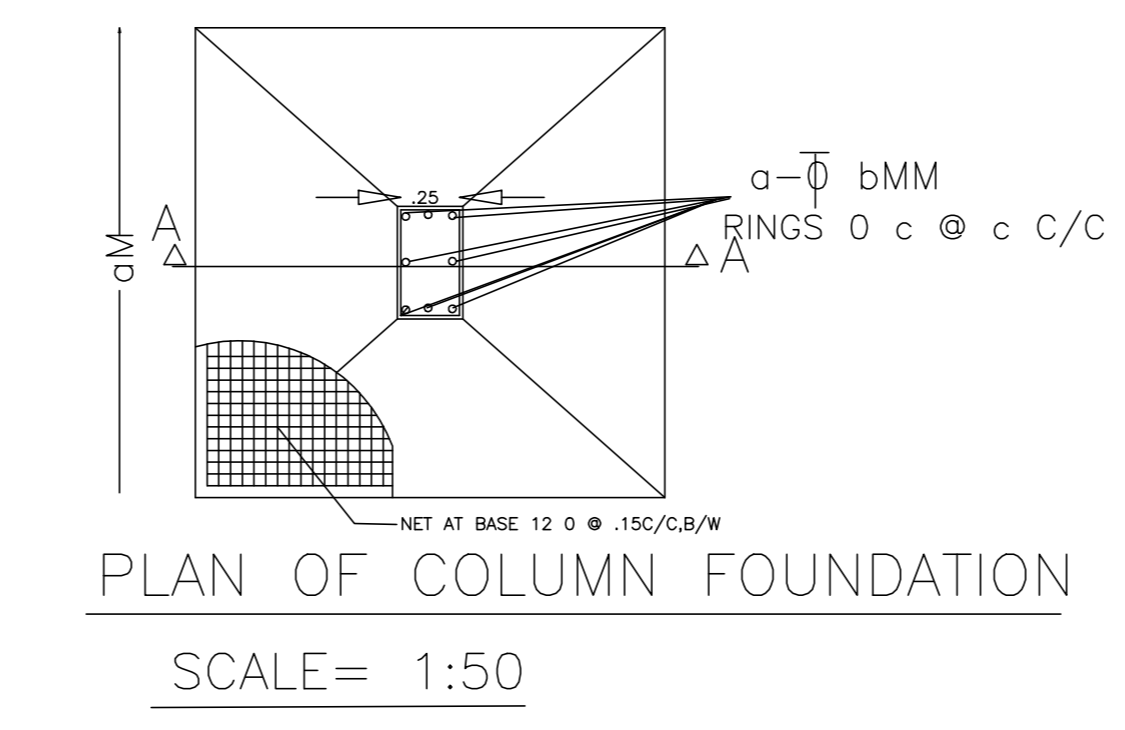
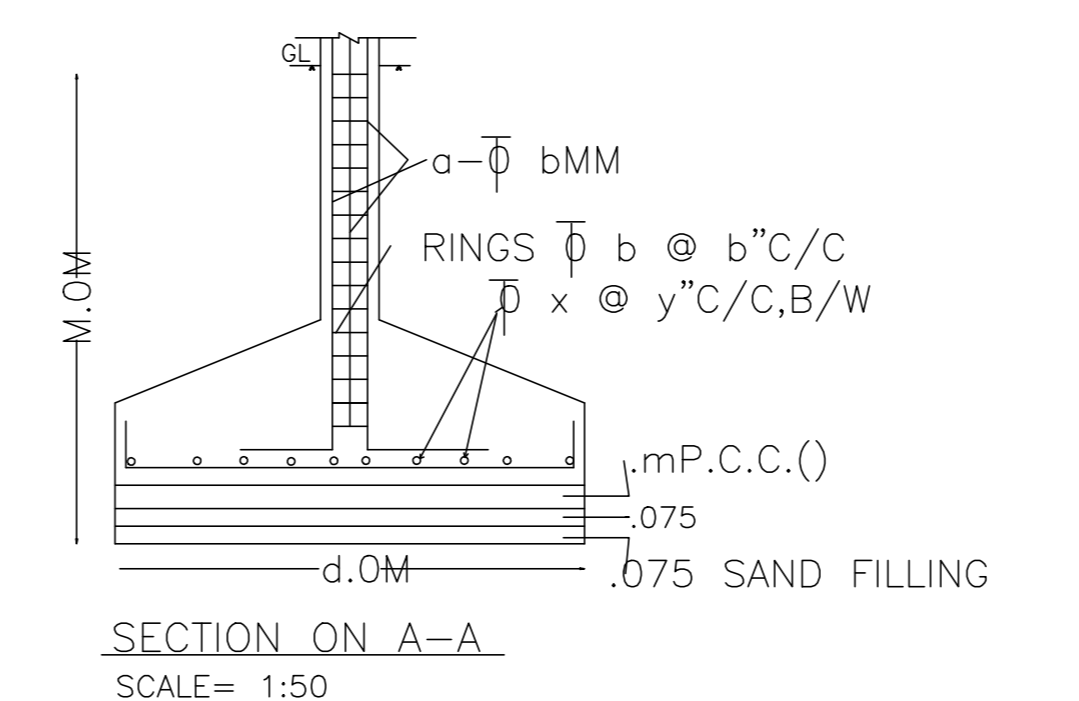
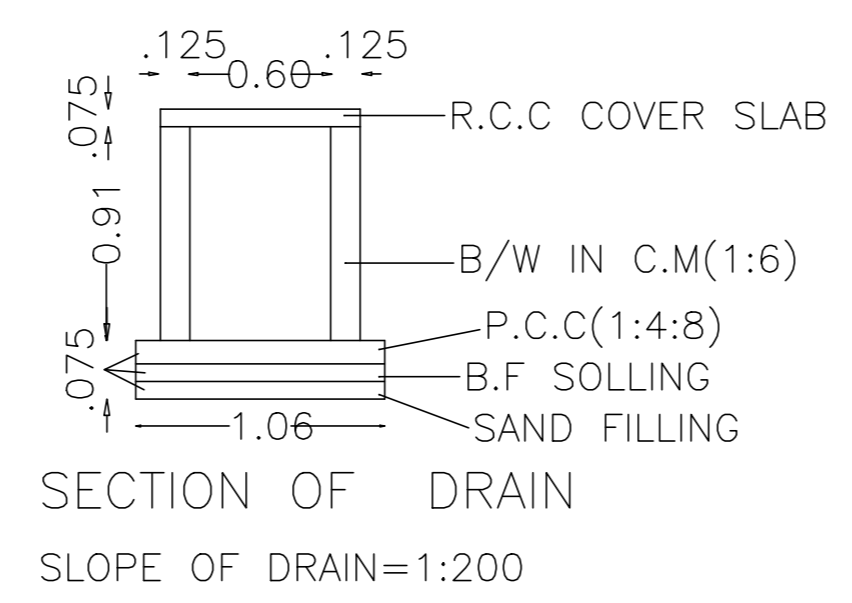

SPECIFICATION

- D.P.C 1:2:4 +2 / C.I.C.O.
- COLUMN &FOOTING R.C.C (1:1.5:3).
- BEAMS, SLAB & LINTEL R.C.C(1:1.5:3:)
- WALLS:- BRICKWORK IN C.M 1:6.
- WINDOWS:-FULLY GLAZED STEEL CASEMENT.
- DOORS:-35MM TH. FLUSH DOORS.
- PLASTER:-1/2" TH. PLASTER ON WALL 1:6.
- WALL FINISH :-DRY DISTEMPER ON INSIDE SNOWCEM ON OUTSIDE.
- FLOORING:-vitrified/ceramic tiles.
- WIRING:-CONCEALED COPPER WIRING.

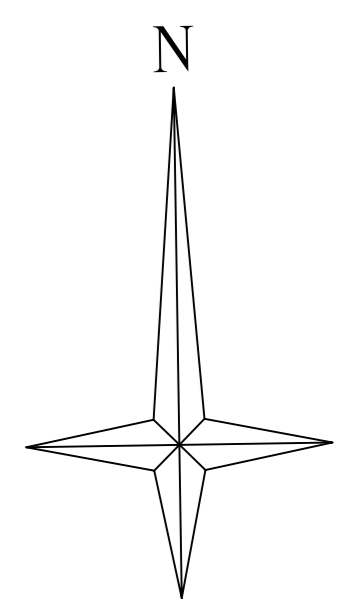

Structure Detail

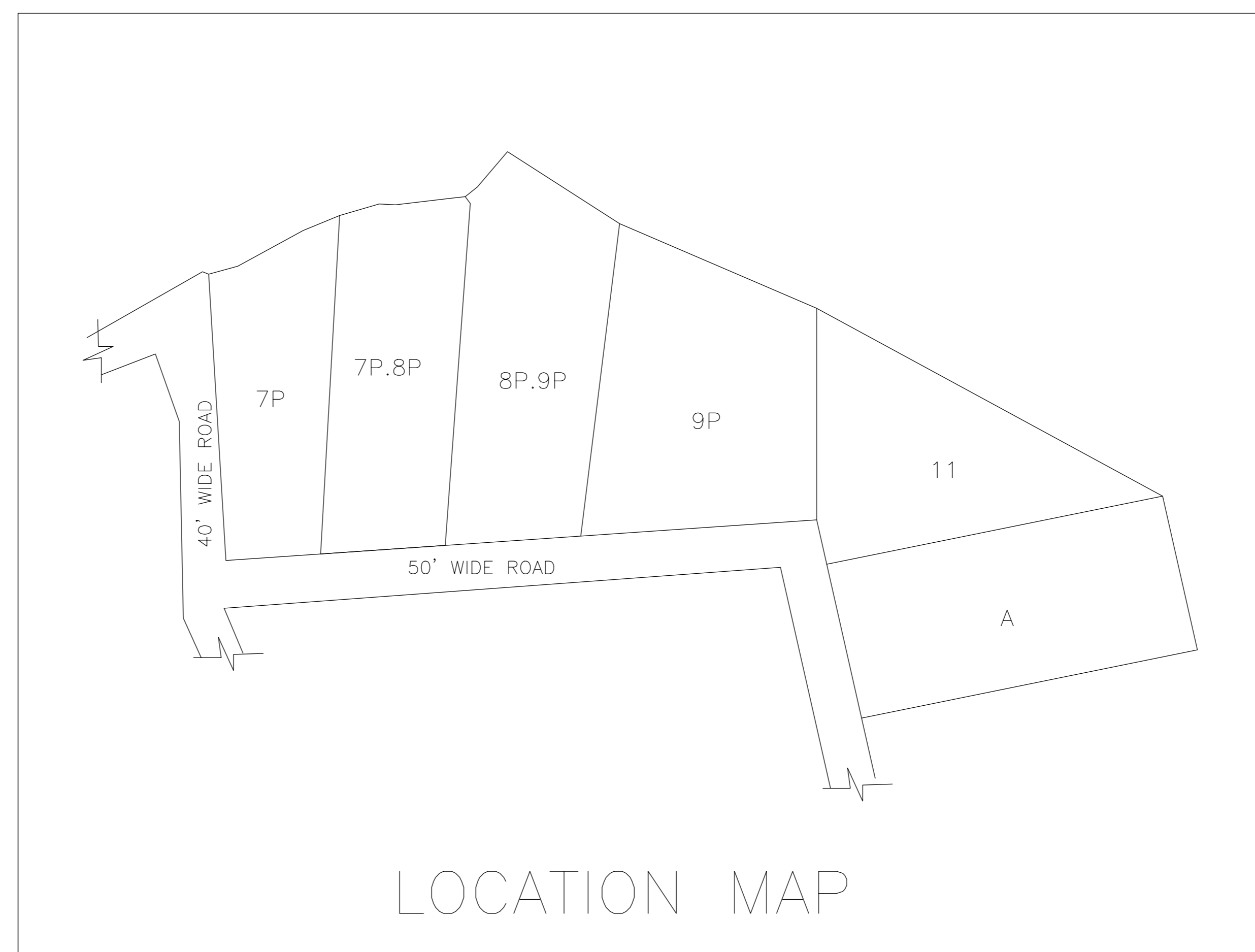

LTP NAME AND SIGNATURE	STRUCTURAL ENGS NAME AND SIGNATURE	BUILDER NAME AND SIGNATURE	DIGITAL SIGNATURE
ZIA UR RAHMAN JADA/NRC/0002/2018			