

Proposal Basic Information	
Proposal File No.	DGMC/BP/0010/W15/2018
Owner Name	JALAJ SHEKHAR SINHA
Khata No	48/3, 25/3635/2
Plot No	485/521
Village Name	Deoghar
Use	Residential
SubUse	Residential Bldg/Apartment

Required Parking (Table 7a)

Building Name	Type	SubUse	Area (Sq.mt.)	Units		Car		Visitors Car		TwoWheeler			
				Reqd.	Prop.	Reqd./Unit	Reqd.	Prop.	Reqd./Unit	Reqd.	Prop.		
A (JALAJ SINHA)	Residential	Residential Bldg/Apartment	>0	1	3.00	1.00	3	-	-	-	1	3	
			>0	1	3.00	-	-	-	-	-	-	-	
			>0	1	3.00	-	-	-	1	1	-	-	-
Total :			-	-	-	-	3	3	-	1	1	3	3

Parking Check (Table 7b)

Vehicle Type	Reqd.		Prop.	
	No.	Area	No.	Area
Car	-	-	3	37.50
Total Car	3	37.50	3	37.50
Visitor's Car Parking	1	12.50	1	12.50
TwoWheeler	3	6.00	3	6.00
Other Parking	-	-	-	80.24
Total	-	56.00	-	136.24

Building USE/SUBUSE Details

Building Name	Building Use	Building SubUse	Building Structure
A (JALAJ SINHA)	Residential	Residential Bldg/Apartment	Non-Highrise

AREA STATEMENT		VERSION NO. : 1.0.27
DEOGHAR MUNICIPAL CORPORATION		VERSION DATE: 18/05/2018
PROJECT DETAIL:		
Region: JHARKHAND URBAN LOCAL BODIES	Plot Use: Residential	
District: DEOGHAR	Plot SubUse: Residential Bldg/Apartment	
Authority: DEOGHAR MUNICIPAL CORPORATION	PlotNearby/ReligiousStructure: NA	
Inward No: DGMC/BP/0010/W15/2018	Plot/SubPlot No: 485/521	
Application Type: General Proposal	North: Road Width - 3	
Project Type: Building Permission	South: Plot No. - MARK (B)	
Nature of Development: New	East: Road Width - 6	
Location of Development Area: Old Area	West: Plot No. - HOUSE OF BUMSANKER PRASAD	
AREA DETAILS:		
AREA OF PLOT (Minimum)	(A)	SQ.MT. 226.67
Deduction for NetPlot Area		
Road Widening Area		3.29
Total		3.29
NET AREA OF PLOT(Gross Plot Area - Deduction from Gross Plot area)	(A-Deductions)	223.38
Deduction for Balance Plot Area(from Gross Plot Area)		
Road Widening Area		3.29
Common Plot		29.12
Total		32.40
BALANCE AREA OF PLOT(Net Plot Area - Recreational/Amenity space)	(A-Deductions)	194.26
PLOT AREA FOR COVERAGE(Net Plot Area)	(A-Deductions)	223.38
Plot Area for FAR (Net Plot Area + RoadWidening Area)	(A-Deductions)	223.38
COVERAGE CHECK		
Permissible Coverage area (60.00 %)		134.03
Proposed Coverage Area (60.00 %)		134.02
Total Prop. Coverage Area (60 %)		134.02
Balance coverage area (- %)		0.01
FAR CHECK		
Perm. FAR Area (2.50)		558.45
Total Perm. FAR area		558.45
Residential FAR		374.43
Proposed FAR Area		386.71
Total Proposed FAR Area		386.71
Consumed FAR (Factor)		1.73
Balance FAR Area		171.74
BUILT UP AREA CHECK		
Total Proposed BuiltUp Area		539.00
ARCHITECT (Regd)		ASHOK KUMAR JHA
ENGINEER (Regd)		
SUPERVISOR (Regd)		
OWNER (Regd)		JALAJ SHEKHAR SINHA
DEVELOPMENT AUTHORITY		LOCAL BODY

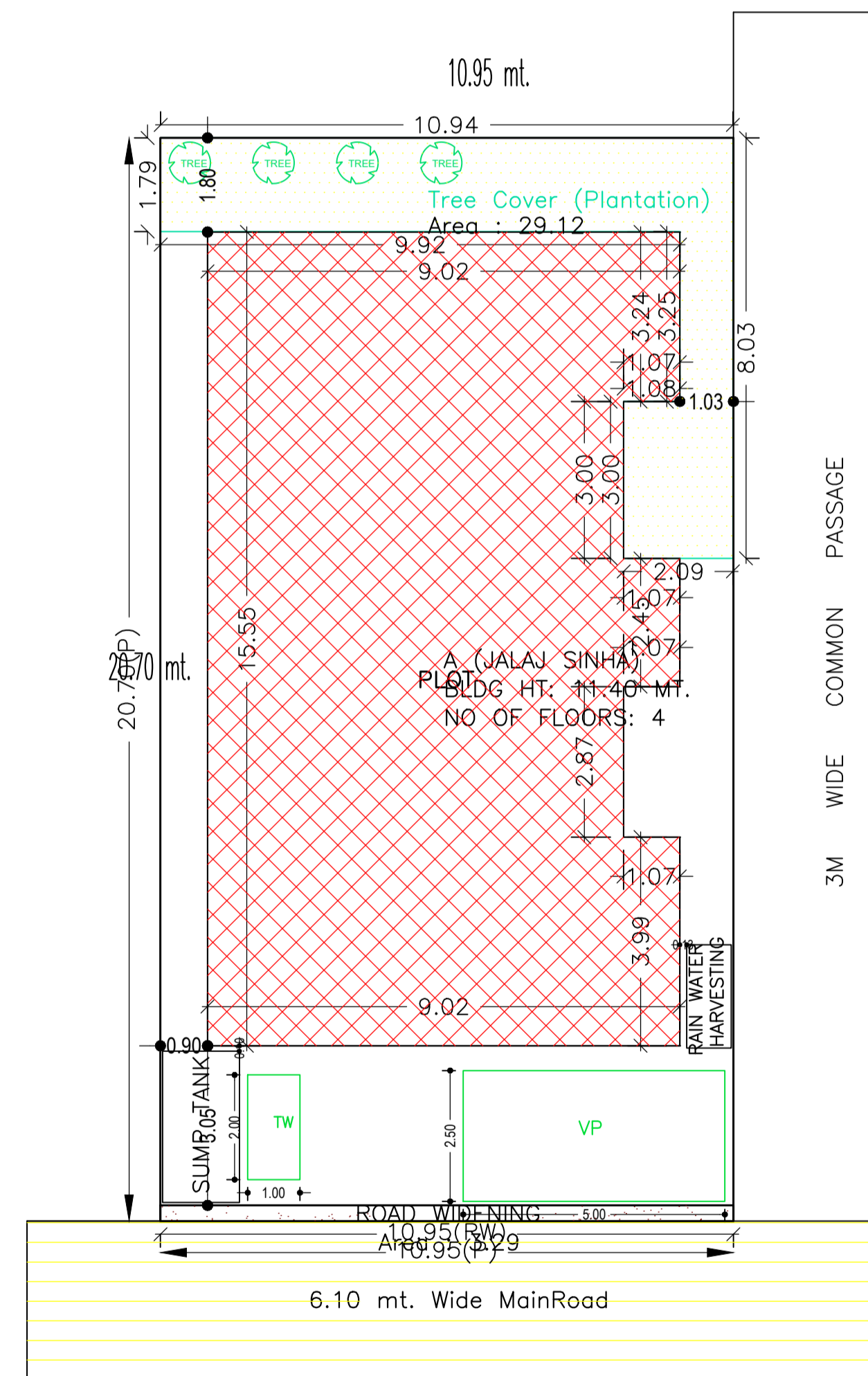

COLOR INDEX	
PLOT BOUNDARY	Black
ABUTTING ROAD	Green
PROPOSED CONSTRUCTION	Red
COMMON PLOT	Yellow
ROAD WIDENING AREA	Light Blue
EXISTING (To be retained)	Dark Blue
EXISTING (To be demolished)	Light Yellow

Buildingwise Floor FAR Details

Floor Name	Building Name A (JALAJ SINHA)		Total	
	Proposed Built Up Area (Sq.mt.)	Proposed FAR Area (Sq.mt.)	Total Proposed Built Up Area (Sq.mt.)	Total FAR Area (Sq.mt.)
Ground Floor	134.03	12.29	134.03	12.29
First Floor	134.03	124.71	134.03	124.71
Second Floor	135.47	124.86	135.47	124.86
Third Floor	135.47	124.86	135.47	124.86
Terrace Floor	0.00	0.00	0.00	0.00
Total :	539.00	386.72	539.00	386.72

FAR & Tenement Details (Table 4c-1)

Building	No. of Same Bldg	Total Built Up Area (Sq.mt.)	Deductions (Area in Sq.mt.)				Proposed FAR Area (Sq.mt.)	Add Area In FAR (Sq.mt.)	Total FAR Area (Sq.mt.)	Total Consumed Additional FAR Area (Sq.mt.)	Tnmt (No.)
			Lift	Balcony	Accessory Use	Parking					
A (JALAJ SINHA)	1	539.00	9.96	2.58	18.00	121.74	374.43	8.97	386.72	386.72	03
Grand Total	1	539.00	9.96	2.58	18.00	121.74	374.43	8.97	386.72	386.72	03

SITE PLAN

LTP NAME AND SIGNATURE	STRUCTURAL ENG'S NAME AND SIGNATURE	BUILDER NAME AND SIGNATURE
ASHOK KUMAR JHA DGMC/ENG/0002/2017		

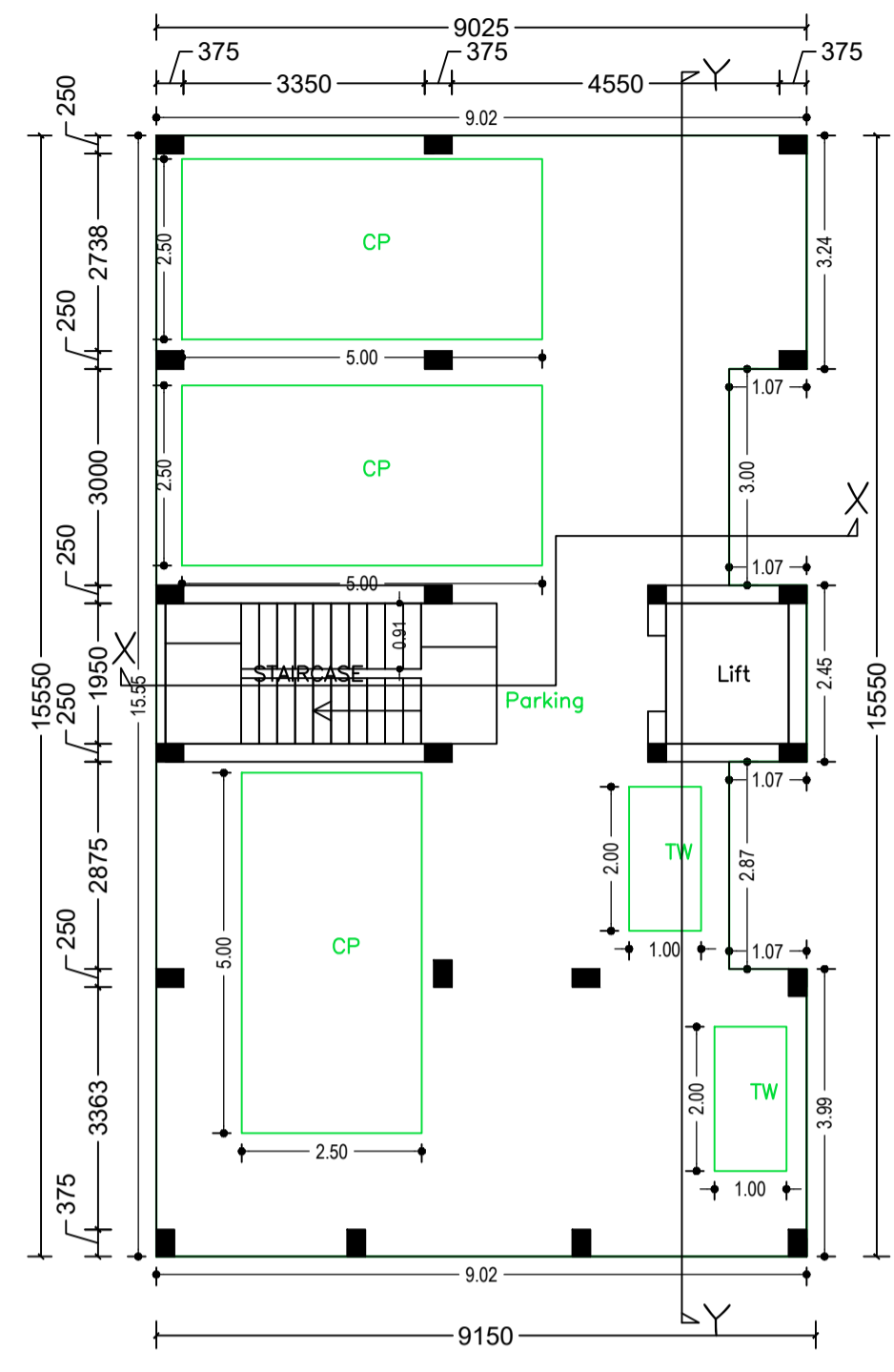

GROUND FLOOR PLAN

GROUND FLOOR PLAN (SCALE 1:100)

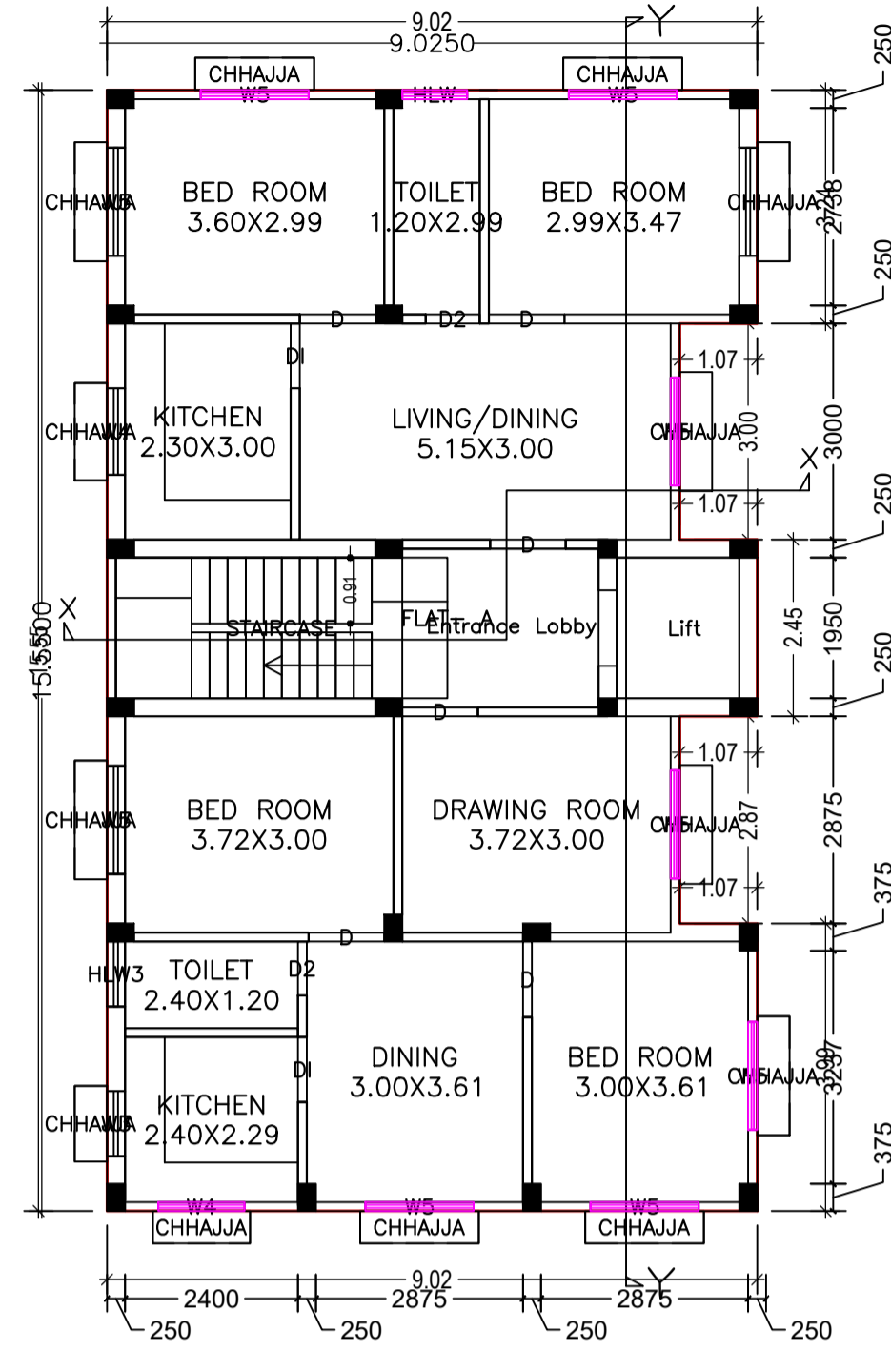

1ST FLOOR PLAN

FIRST FLOOR PLAN (Proposed) (SCALE 1:100)

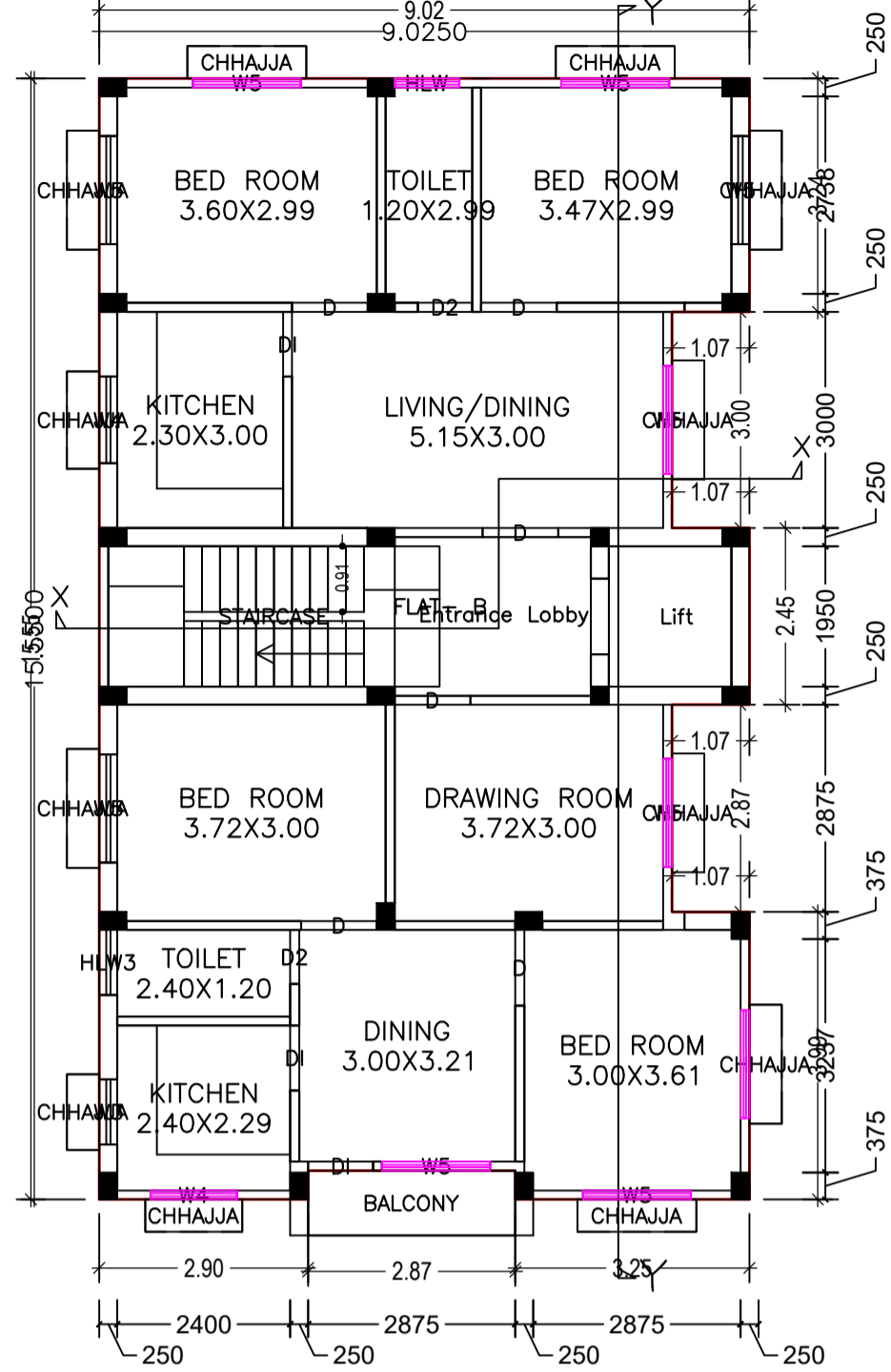

2ND & 3RD FLOOR PLAN

TYPICAL - 2& 3 FLOOR PLAN (Proposed) (SCALE 1:100)

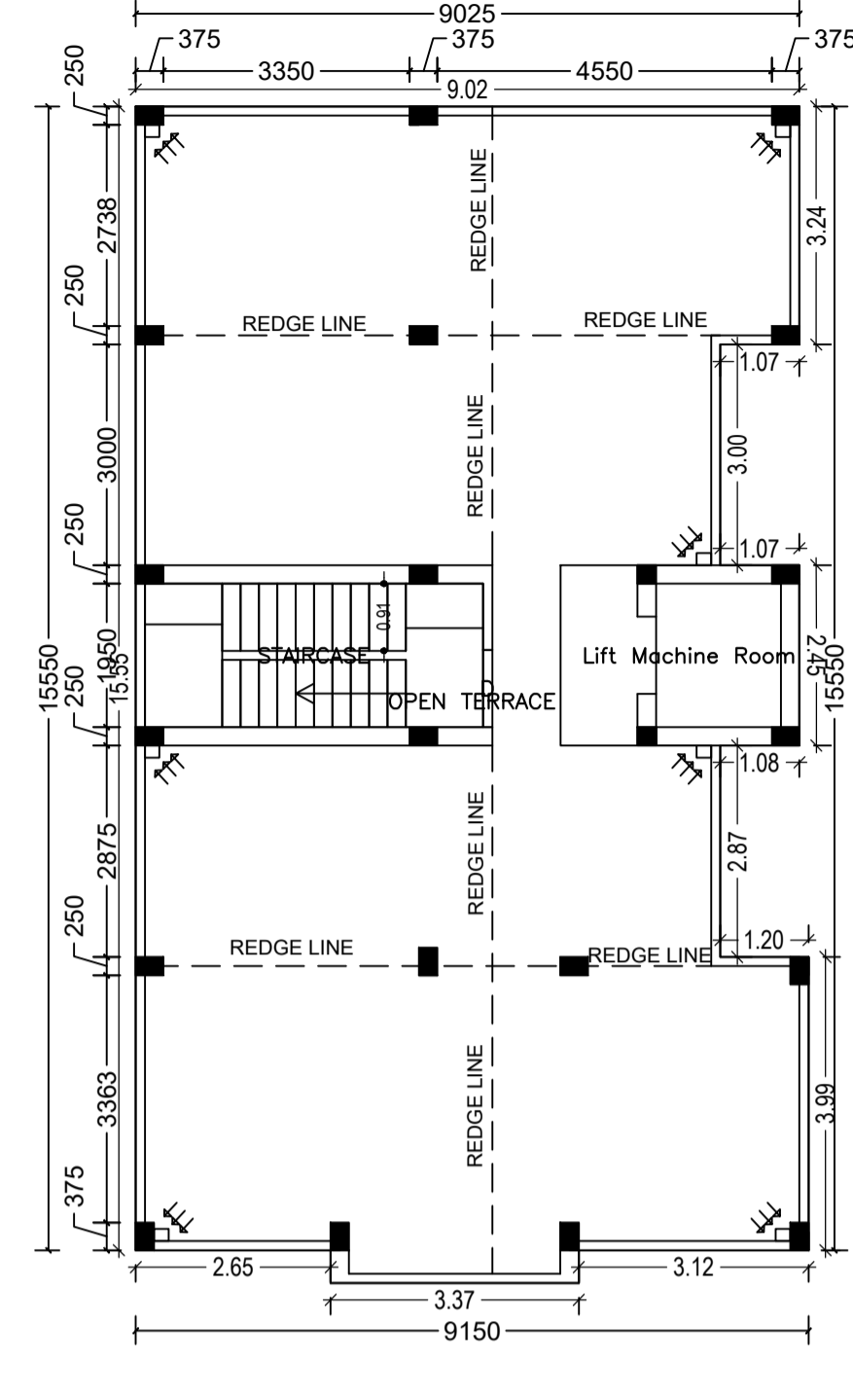

TERRACE PLAN

TERRACE FLOOR PLAN (SCALE 1:100)

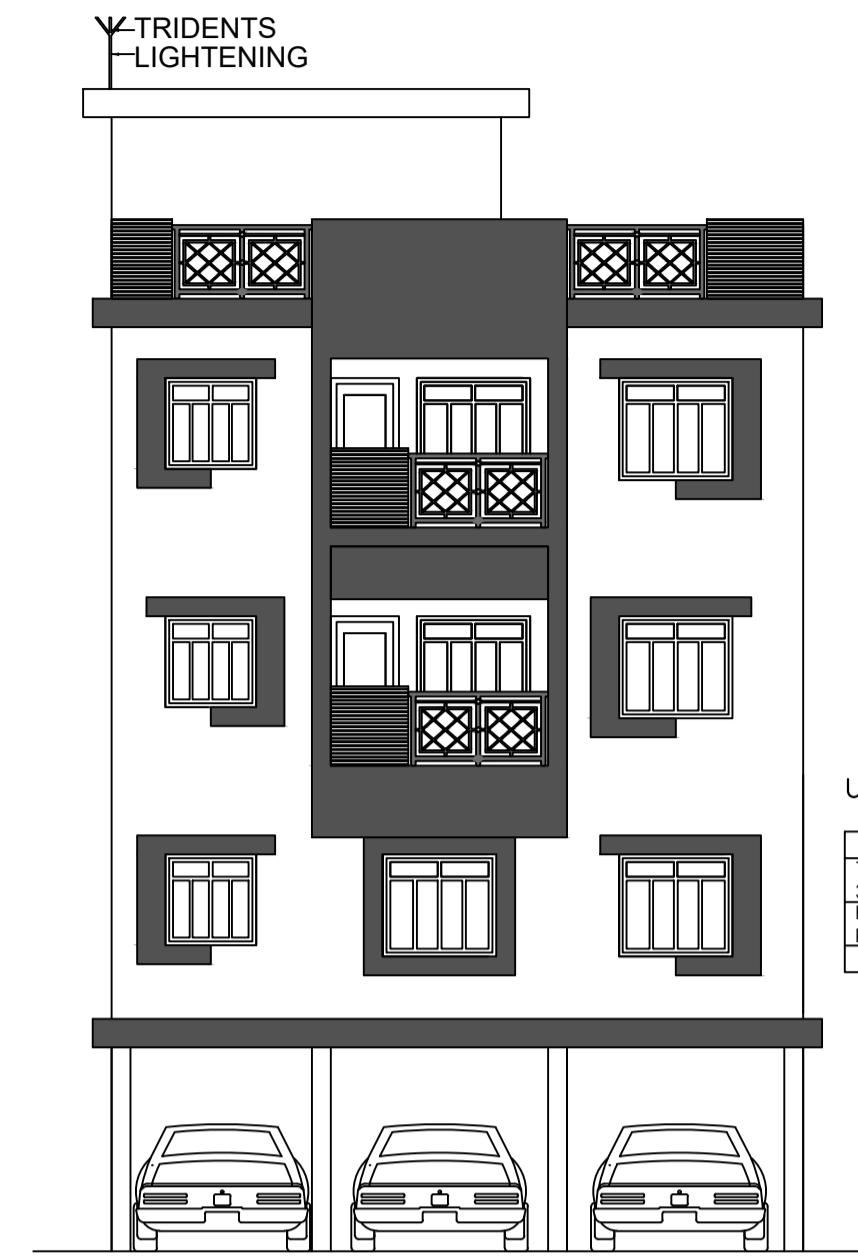

FRONT ELEVATION

Proposal Basic Information

Proposal File No.	DGMC/BP/0010/W15/2018
Owner Name	JALAJ SHEKHAR SINHA
Khata No	48/3, 25/3635/2
Plot No	485/521
Village Name	Deoghar
Use	Residential
SubUse	Residential Bldg/Apartment

Balcony Calculations Table

FLOOR	SIZE	AREA	TOTAL AREA
TYPICAL - 2& 3 FLOOR PLAN	0.45 X 0.00 X 1 X 2	5.18	5.18
Total			5.18

UnitBUA Table for Building :A (JALAJ SINHA)

FLOOR	Name	UnitBUA Type	UnitBUA Area	Carpet Area	No. of Rooms	No. of Tenement
3 FLOOR PLAN	FLAT - B	FLAT	111.13	106.06	11	2
FIRST FLOOR PLAN	FLAT - A	FLAT	112.43	107.25	11	1
Total			334.69	319.37	33	3

SCHEDULE OF DOOR:

BUILDING NAME	NAME	LENGTH	HEIGHT	NOS
A (JALAJ SINHA)	D2	0.75	2.10	06
A (JALAJ SINHA)	D3	0.50	2.10	08
A (JALAJ SINHA)	D	1.05	2.10	18

SCHEDULE OF WINDOW/VENTILATION:

BUILDING NAME	NAME	LENGTH	HEIGHT	NOS
A (JALAJ SINHA)	HLW3	0.90	0.45	03
A (JALAJ SINHA)	HLV	0.90	0.90	03
A (JALAJ SINHA)	W3	0.90	1.20	03
A (JALAJ SINHA)	W4	1.20	1.20	03
A (JALAJ SINHA)	W4	1.20	1.35	03
A (JALAJ SINHA)	WS	1.50	1.35	27

Building :A (JALAJ SINHA)

Floor Name	Total Built Up Area (Sq.mt.)	Lift	Balcony	Accessory Use	Parking	Proposed FAR Area in FAR (Sq.mt.)	Add Area in FAR (Sq.mt.)	Total FAR Area (Sq.mt.)	Total Consumed Additional FAR Area (Sq.mt.)	Trmt (No.)
Ground Floor	134.03	0.00	0.00	0.00	121.74	0.00	8.97	12.29	12.29	00
First Floor	134.03	3.32	0.00	6.00	0.00	124.71	0.00	124.71	124.71	01
Second Floor	134.47	3.32	1.29	6.00	0.00	134.86	0.00	134.86	134.86	01
Third Floor	134.47	3.32	1.29	6.00	0.00	134.86	0.00	134.86	134.86	01
Terrace Floor	0.00	0.00	0.00	0.00	0.00	0.00	0.00	0.00	0.00	00
Total	539.00	9.96	2.58	18.00	121.74	374.43	8.97	388.72	388.72	03
Total Number of Same Buildings	1									
Total	539.00	9.96	2.58	18.00	121.74	374.43	8.97	388.72	388.72	03

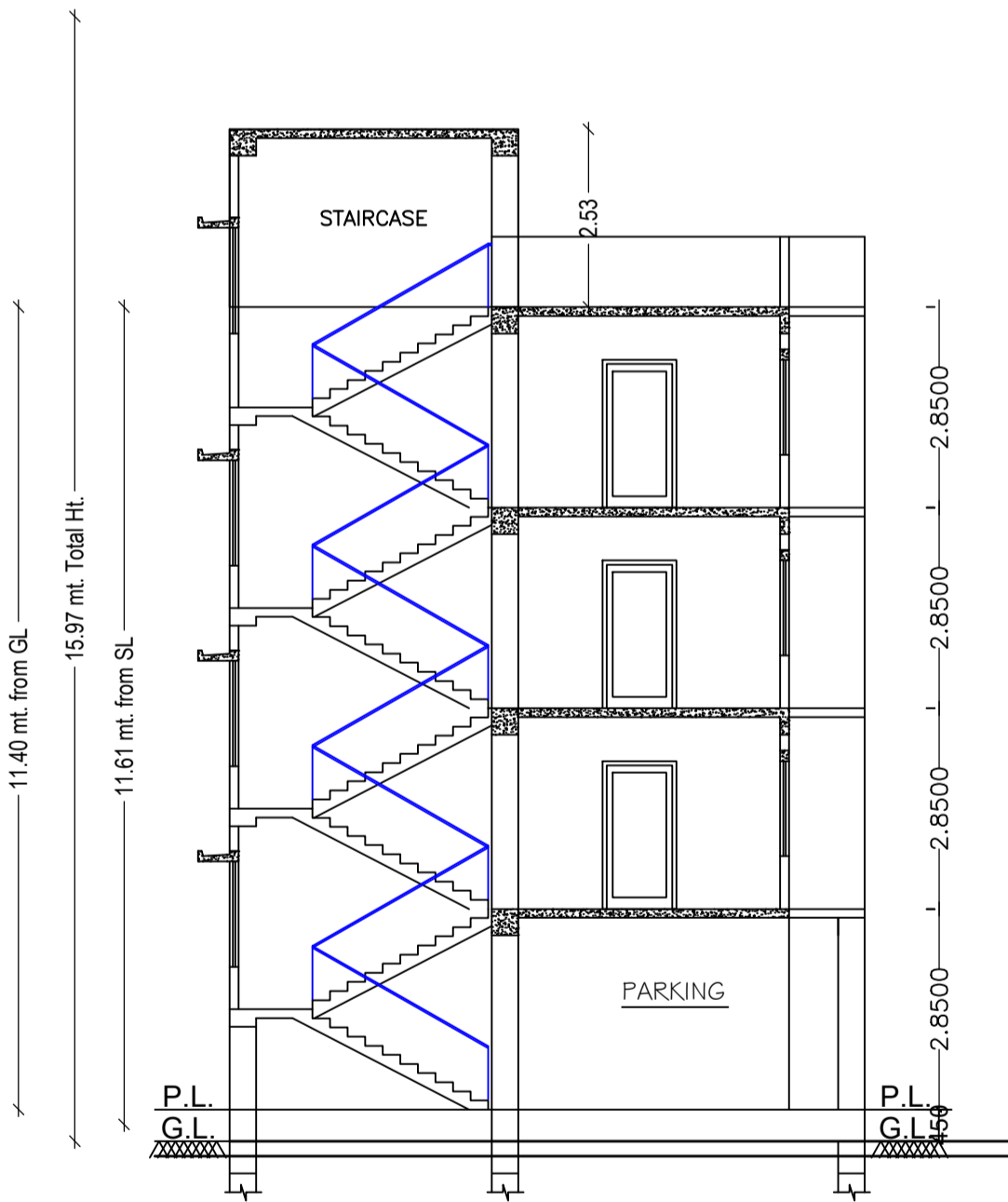

25mm ARTIFICAL STONE OVER CROSS - SECTION ON A-A

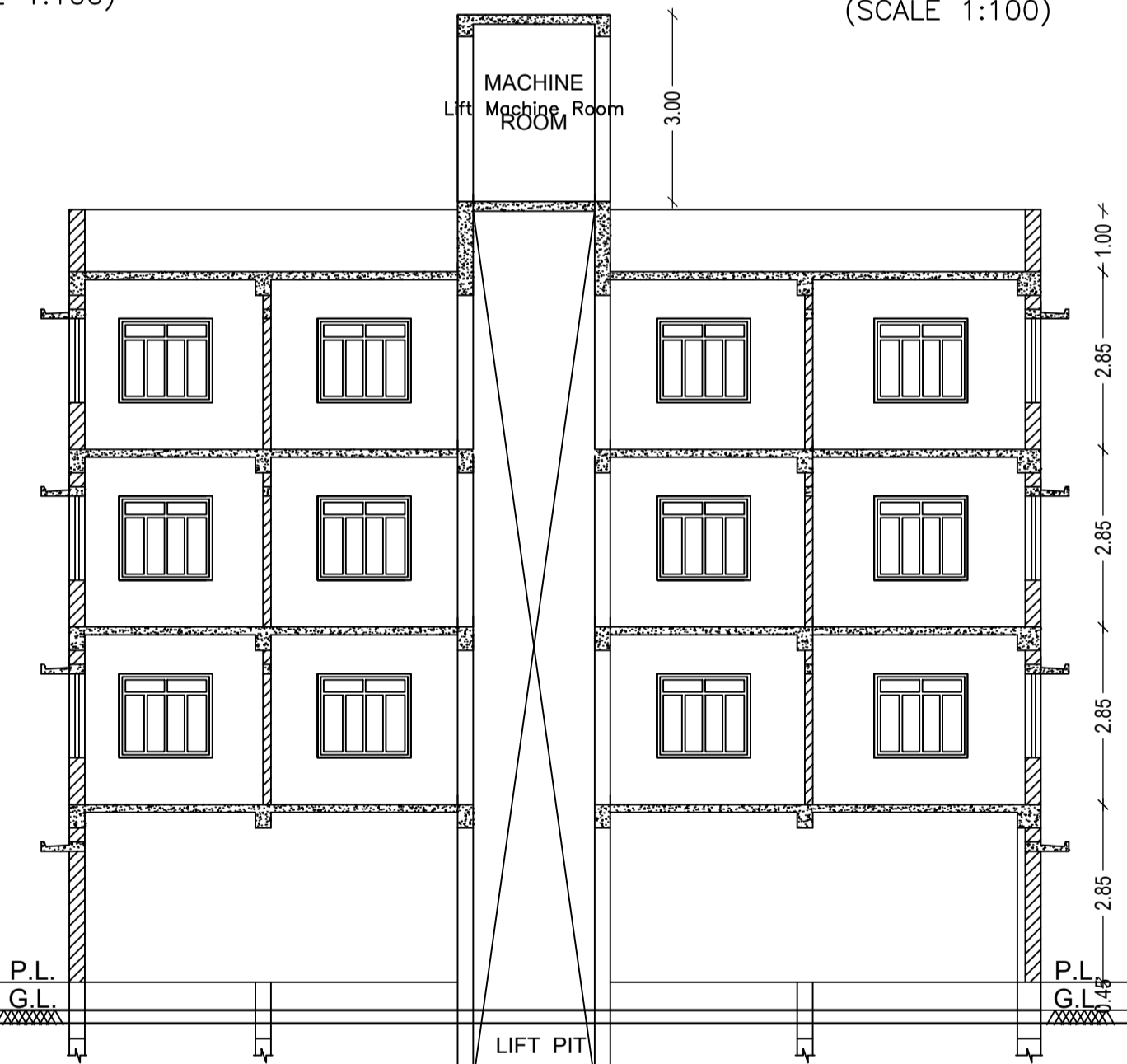

25mm ARTIFICAL STONE OVER SECTION AT - YY

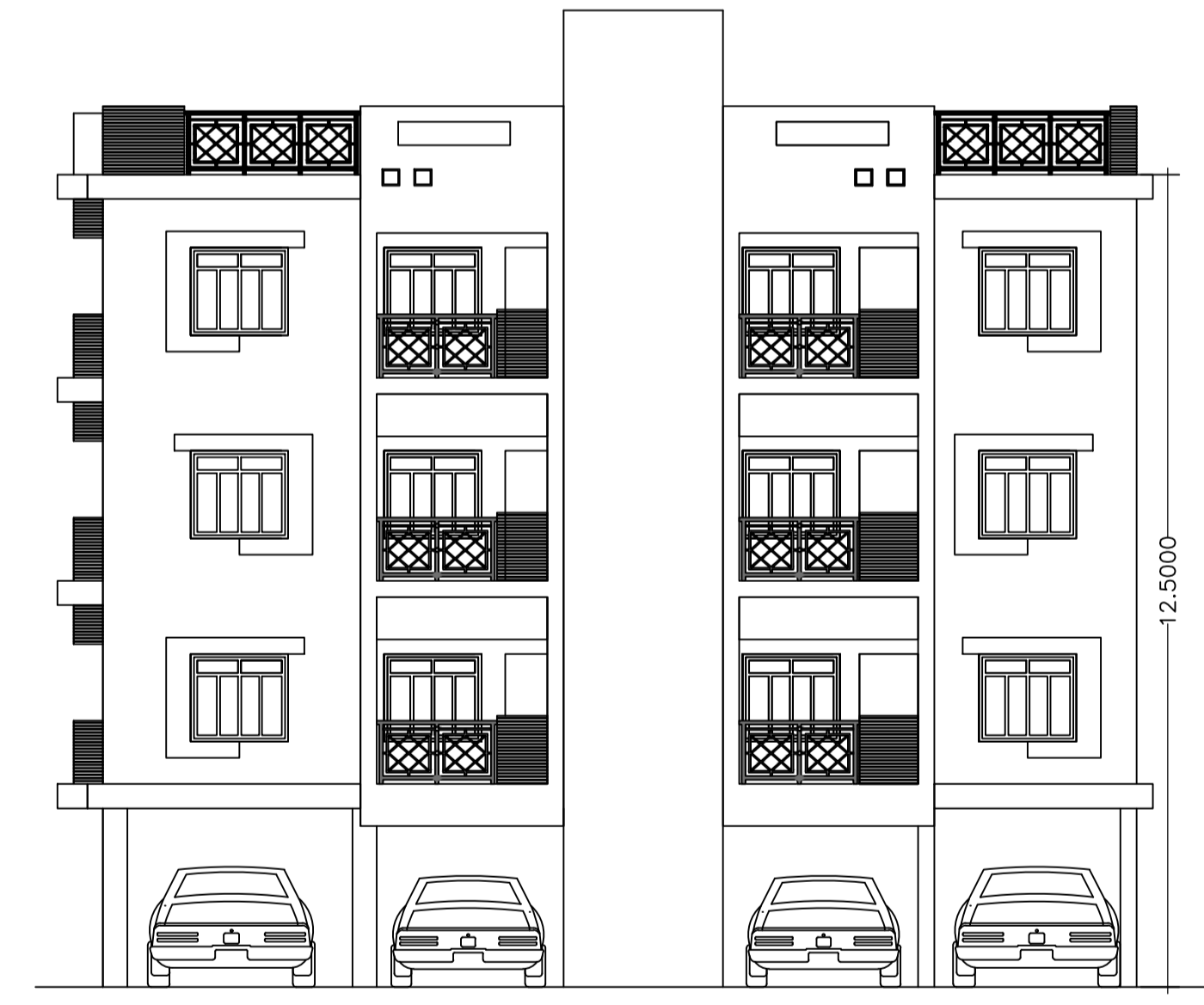

RIGHT SIDE ELEVATION

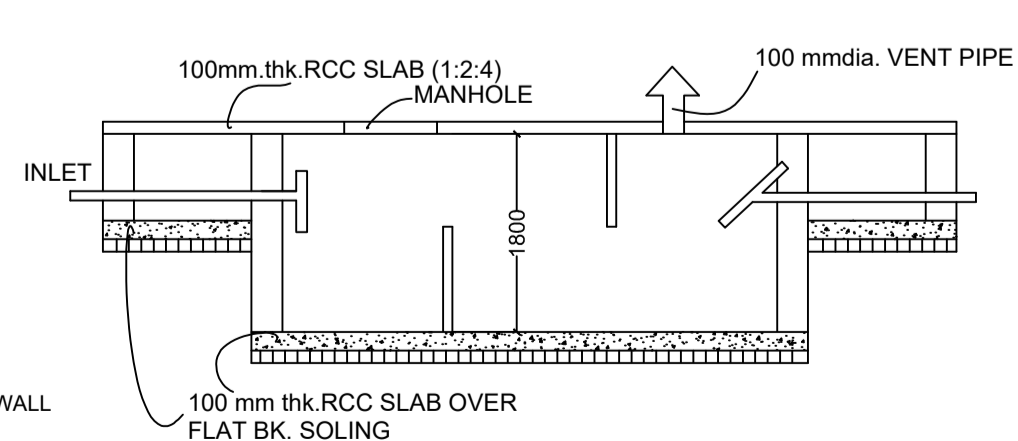
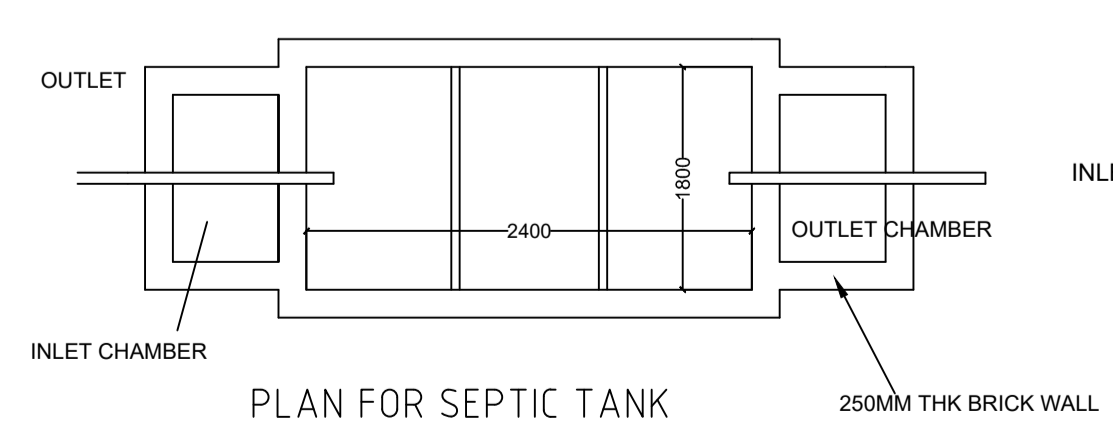
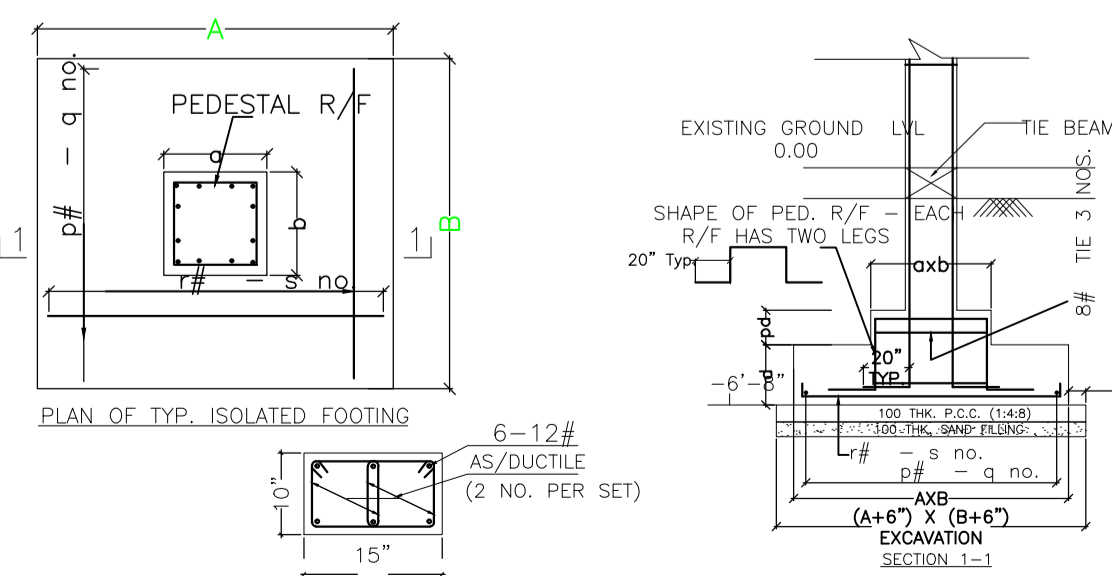

SECTION SCALE 1:50 SEPTIC TANK DETAILS

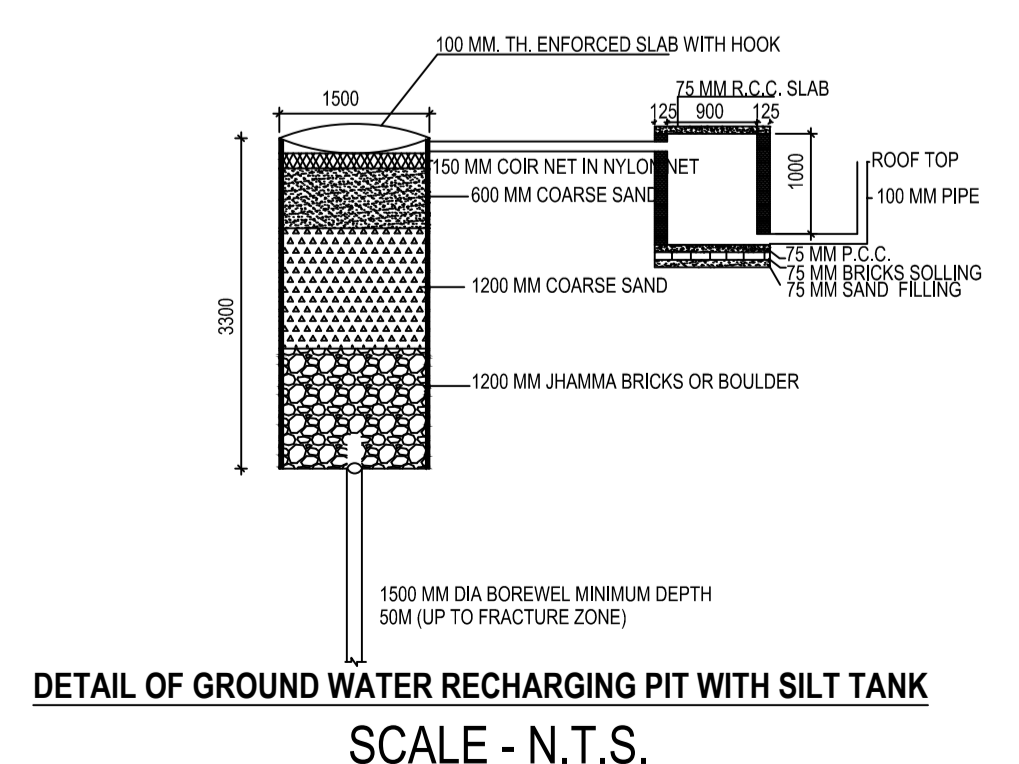

DETAIL OF GROUND WATER RECHARGING PIT WITH SILT TANK SCALE - N.T.S.



THIS IS SATFY THAT THE STRUCTURAL DESINE OF THIS BUILDING IS AS PER IS CODE 189-1884-& 1993 TO MAKE THE SAME EARTH QUAKE RESISTANT.

Certificate

LTP NAME AND SIGNATURE	STRUCTURAL ENG'S NAME AND SIGNATURE	BUILDER NAME AND SIGNATURE
ASHOK KUMAR JHA DGMC/ENG/0002/2017		