

Proposal Basic Information	
Proposal File No.	DGMC/BP/0045/W22/2018
Owner Name	SRI BRAJESH KUMAR TIWARI
Khata No	246
Plot No	16
Village Name	Deoghar
Use	Residential
SubUse	Residential Bldg/Apartment

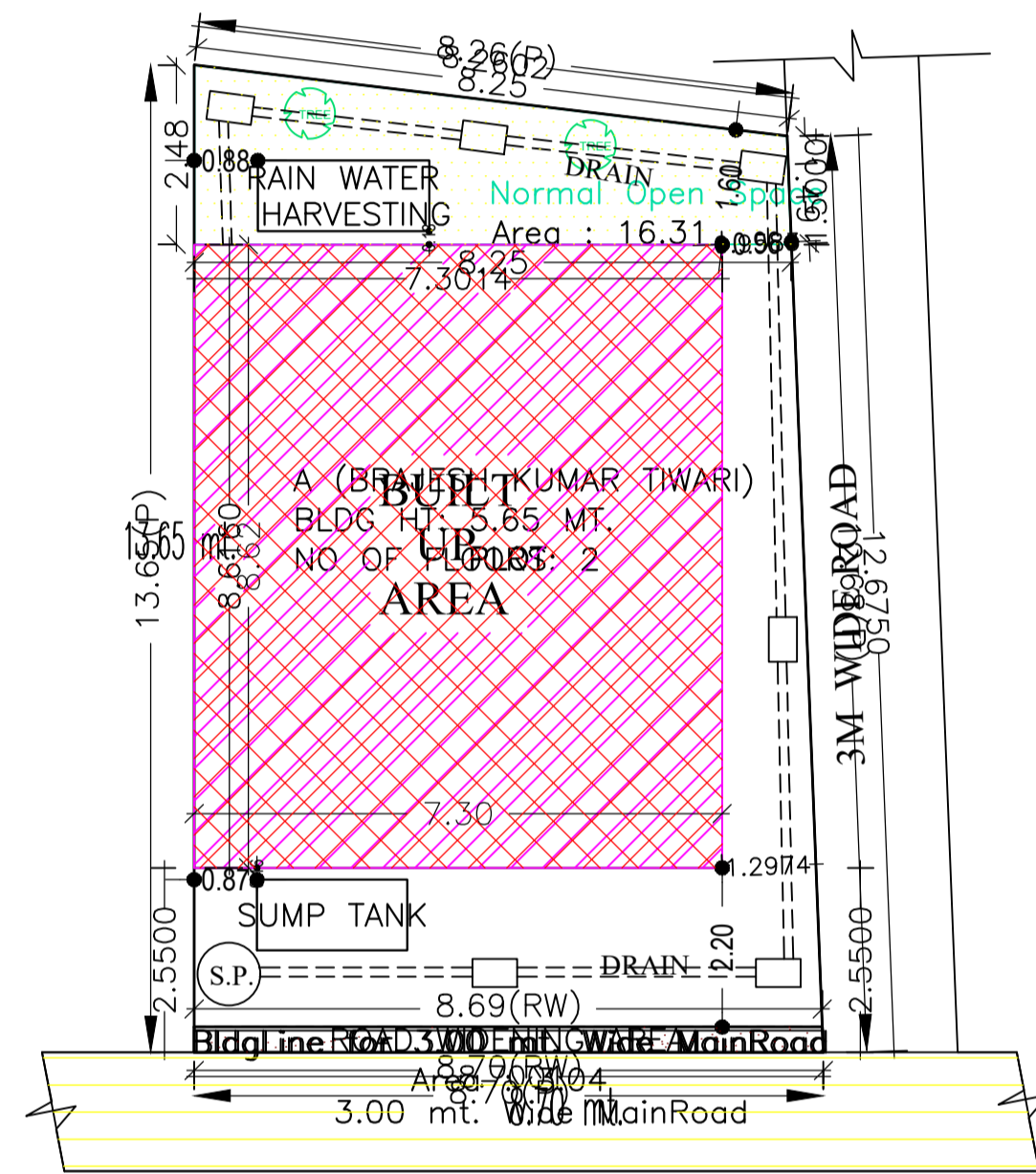

SITE PLAN

FAR & Tenement Details (Table 4c-1)

Building	No. of Same Bldg	Total Built Up Area (Sq.mt.)	Deductions (Area in Sq.mt.)		Proposed FAR Area (Sq.mt.)	Total FAR Area (Sq.mt.)	Total Consumed Additional FAR Area (Sq.mt.)	Trmt (No.)
			Archi.Proj.	Resi.				
A (BRAJESH KUMAR TIWARI)	1	142.86	17.04		125.82	125.82	125.82	01
<b>Grand Total :</b>	<b>1</b>	<b>142.86</b>	<b>17.04</b>		<b>125.82</b>	<b>125.82</b>	<b>125.82</b>	<b>01</b>

AREA STATEMENT		VERSION NO. : 1.0.28
DEOGHAR MUNICIPAL CORPORATION		VERSION DATE: 30/06/2018
<b>PROJECT DETAIL:</b>		
Region: JHARKHAND URBAN LOCAL BODIES	Plot Use: Residential	
District: DEOGHAR	Plot SubUse: Residential Bldg/Apartment	
Authority: DEOGHAR MUNICIPAL CORPORATION	PlotNearbyReligiousStructure: NA	
Inward_No: DGMC/BP/0045/W22/2018	Plot/SubPlot No: 16	
Application Type: General Proposal	North: Plot No. - VENDORS LAND	
Project Type: Building Permission	South: Road Width - 3	
Nature of Development: New	East: Road Width - 3	
Location of Development Area: Old Area	West: Plot No. - LAND OF BIPIN DUBEY	
<b>AREA DETAILS:</b>		
AREA OF PLOT (Minimum)	(A)	111.07
Deduction for NetPlot Area		
Road Widening Area		3.04
Total		3.04
NET AREA OF PLOT(Gross Plot Area - Deduction from Gross Plot area)	(A-Deductions)	108.03
Deduction for Balance Plot Area(from Gross Plot Area)		
Road Widening Area		3.04
Common Plot		16.31
Total		19.35
BALANCE AREA OF PLOT(Net Plot Area - Recreational/Amenity space)	(A-Deductions)	91.72
PLOT AREA FOR COVERAGE(Net Plot Area)	(A-Deductions)	108.03
Plot Area for FAR (Net Plot Area + RoadWidening Area)	(A-Deductions)	108.03
<b>COVERAGE CHECK</b>		
Permissible Coverage area ( 70.00 % )		75.62
Proposed Coverage Area ( 58.24 % )		62.91
Total Prop. Coverage Area ( 58.24 % )		62.91
Balance coverage area ( 11.77 % )		12.71
<b>FAR CHECK</b>		
Perm. FAR Area ( 1.20 )		129.64
Total Perm. FAR area		129.64
Residential FAR		125.82
Proposed FAR Area		125.82
Total Proposed FAR Area		125.82
Consumed FAR (Factor)		1.16
Balance FAR Area		3.82
<b>BUILT UP AREA CHECK</b>		
Total Proposed BuiltUp Area		142.86
ARCHITECT (Regd)	ALOK KUMAR SINGH	
ENGINEER (Regd)		
SUPERVISOR (Regd)		
OWNER (Regd)	SRI BRAJESH KUMAR TIWARI	
DEVELOPMENT AUTHORITY		LOCAL BODY

COLOR INDEX	
PLOT BOUNDARY	Black
ABUTTING ROAD	Green
PROPOSED CONSTRUCTION	Red
COMMON PLOT	Yellow
ROAD WIDENING AREA	Orange
EXISTING (To be retained)	Blue
EXISTING (To be demolished)	Light Blue

Buildingwise Floor FAR Details

Floor Name	Building Name		Total	
	Proposed Built Up Area (Sq.mt.)	Proposed FAR Area (Sq.mt.)	Total Proposed Built Up Area (Sq.mt.)	Total FAR Area (Sq.mt.)
Ground Floor	79.95	62.91	79.95	62.91
First Floor	62.91	62.91	62.91	62.91
Terrace Floor	0.00	0.00	0.00	0.00
<b>Total :</b>	<b>142.86</b>	<b>125.82</b>	<b>142.86</b>	<b>125.82</b>

Building USE/SUBUSE Details

Building Name	Building Use	Building SubUse	Building Structure
A (BRAJESH KUMAR TIWARI)	Residential	Residential Bldg/Apartment	Non-Highrise

LTP NAME AND SIGNATURE	STRUCTURAL ENG'S NAME AND SIGNATURE	BUILDER NAME AND SIGNATURE
ALOK KUMAR SINGH DGMC/ENG/0007/2017		

Proposal Basic Information	
Proposal File No.	DGMC/BP/0045/W22/2018
Owner Name	SRI BRAJESH KUMAR TIWARI
Khata No	246
Plot No	16
Village Name	Deoghar
Use	Residential
SubUse	Residential Bldg/Apartment

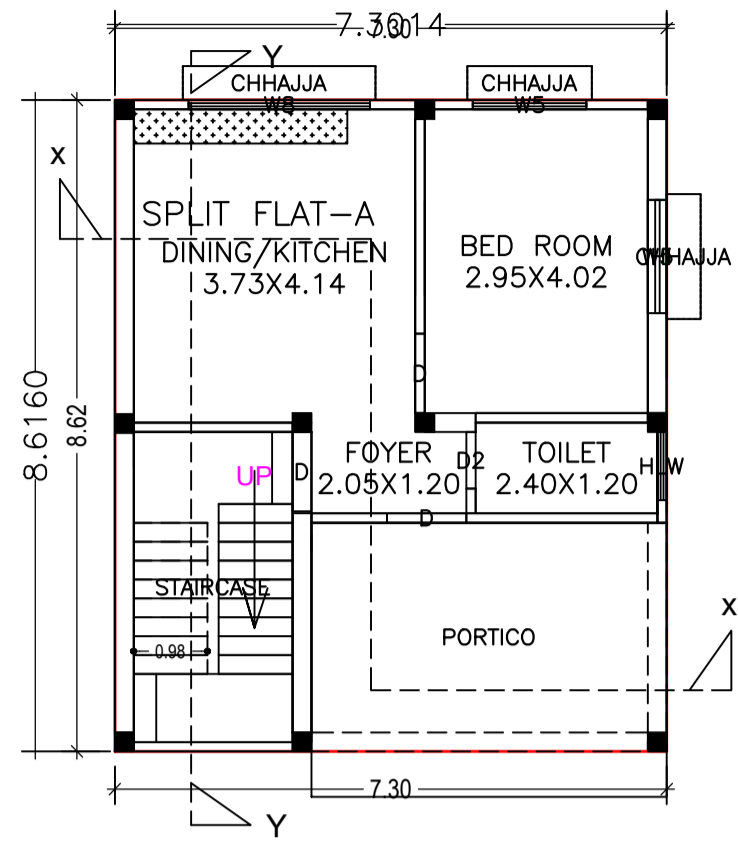

GROUND FLOOR PLAN

GROUND FLOOR PLAN  
(Proposed)  
(SCALE 1:100)

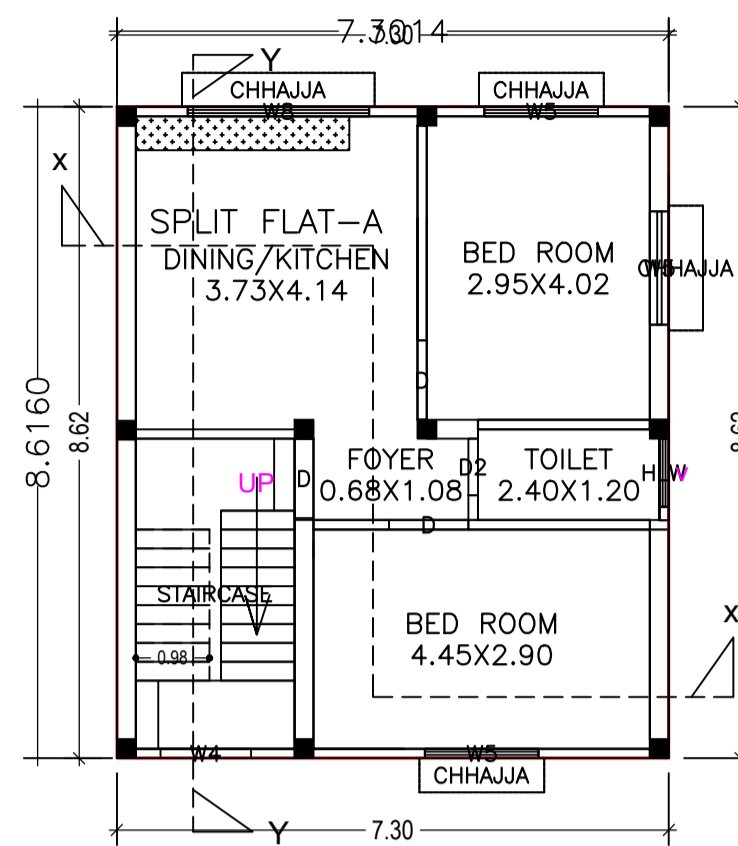

1ST FLOOR PLAN

FIRST FLOOR PLAN  
(Proposed)  
(SCALE 1:100)

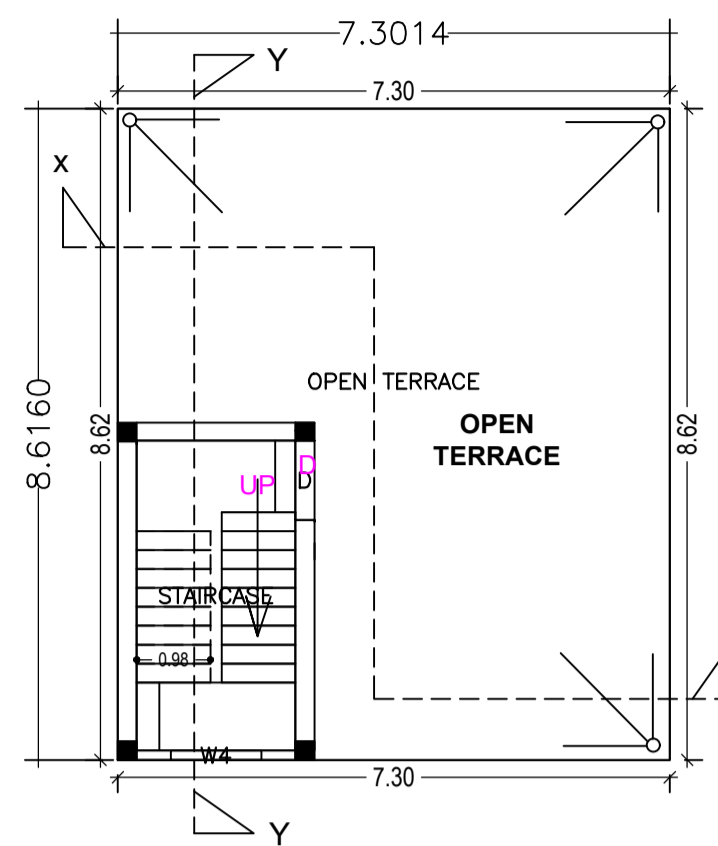

TERRACE FLOOR PLAN

TERRACE FLOOR PLAN  
(SCALE 1:100)

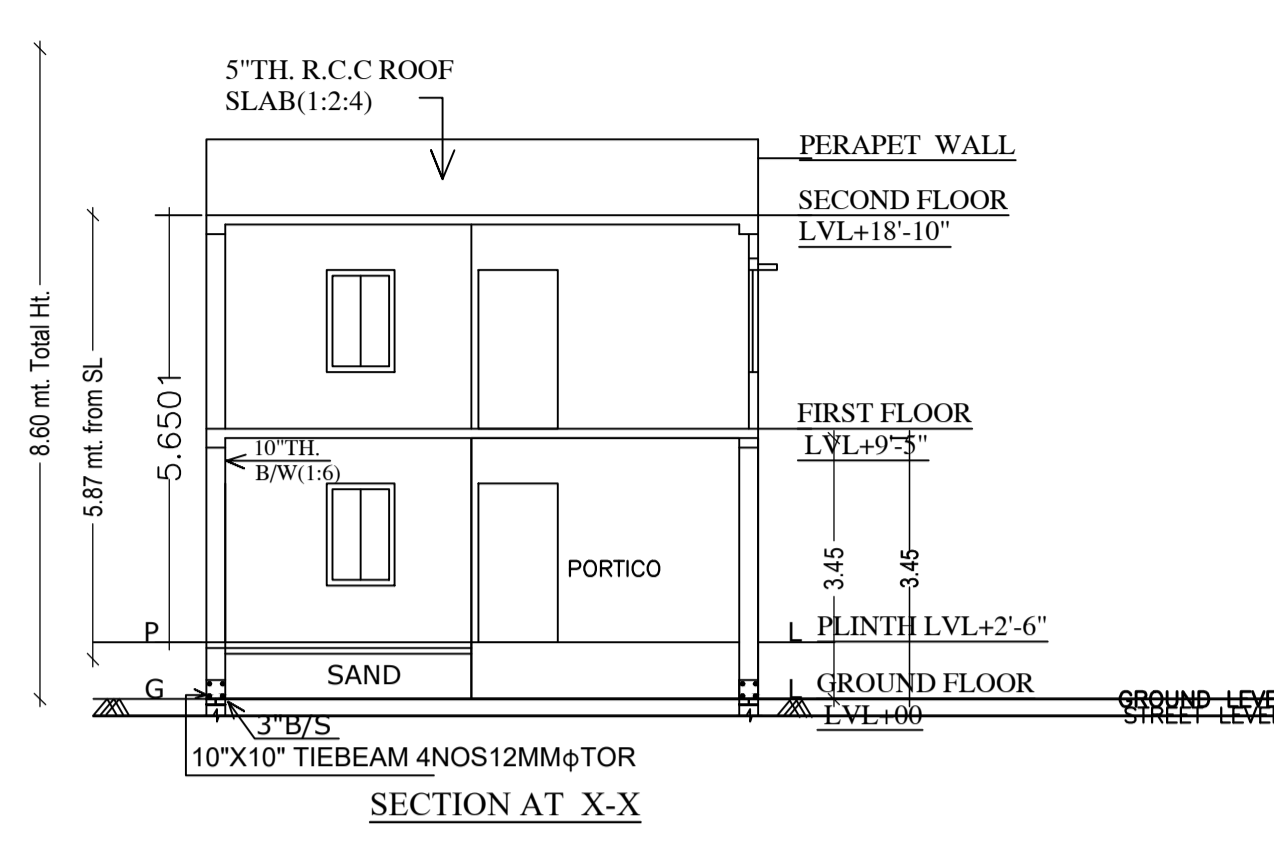

SECTION AT X-X

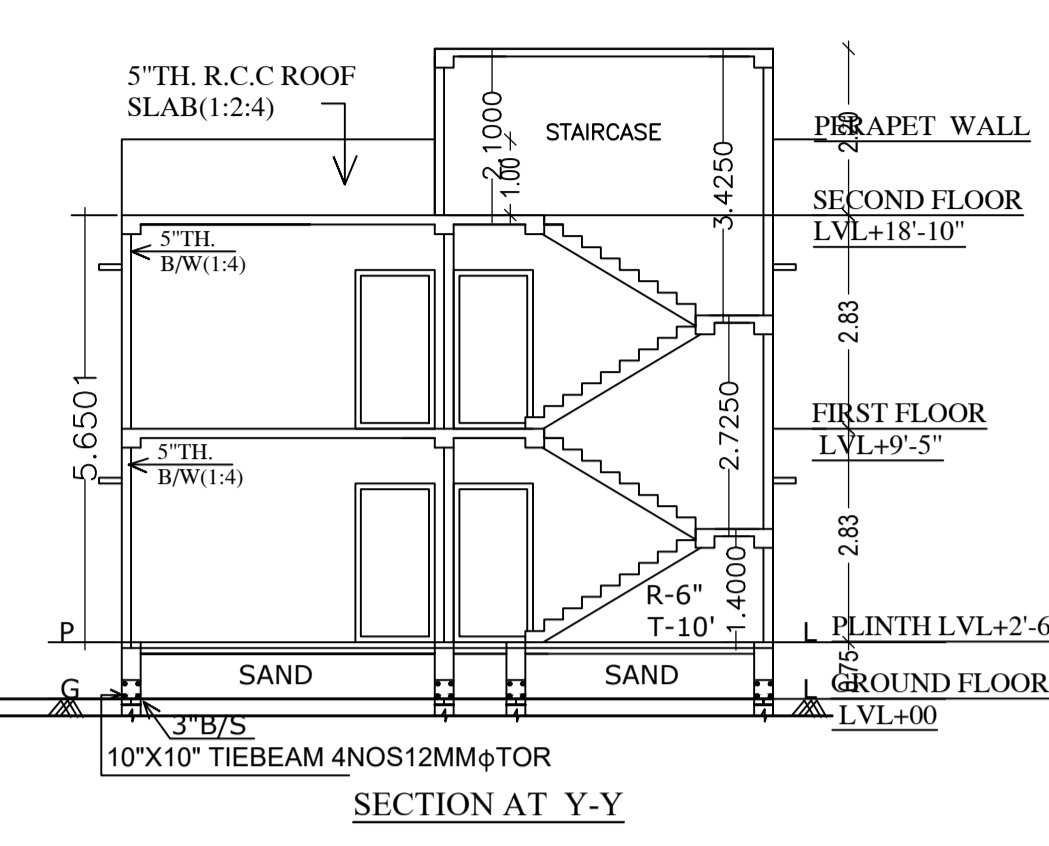

SECTION AT Y-Y

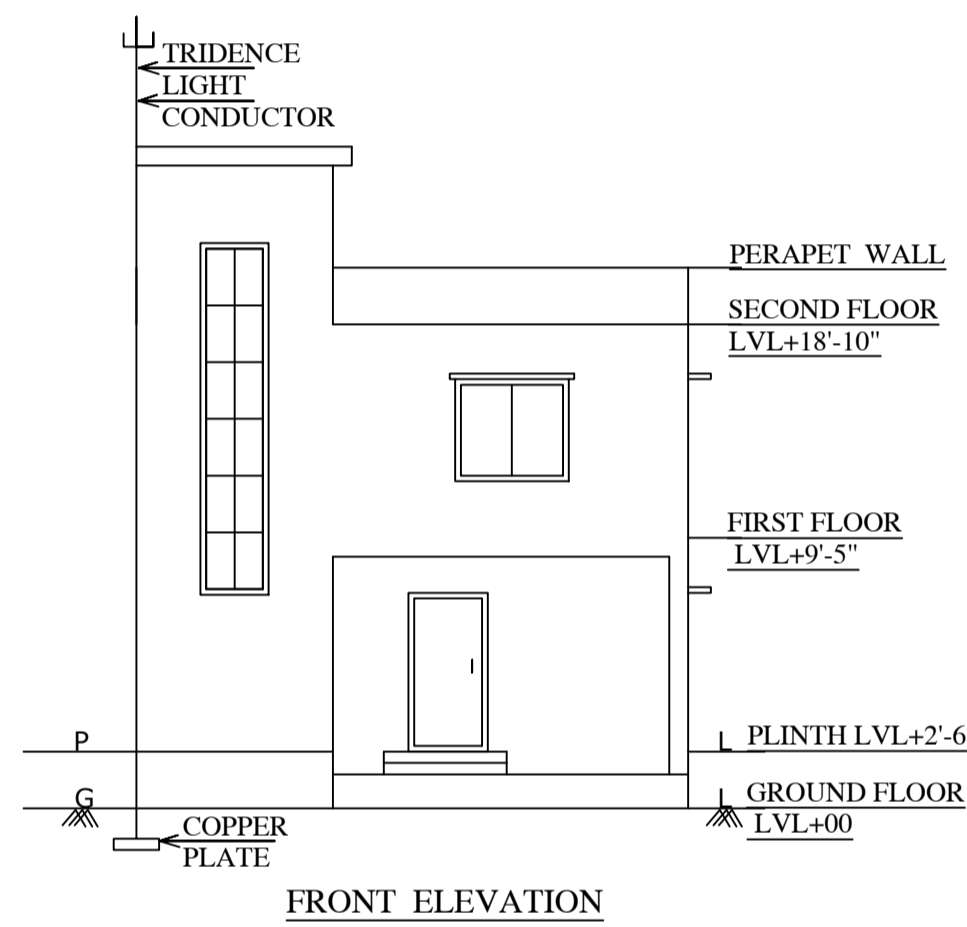

FRONT ELEVATION

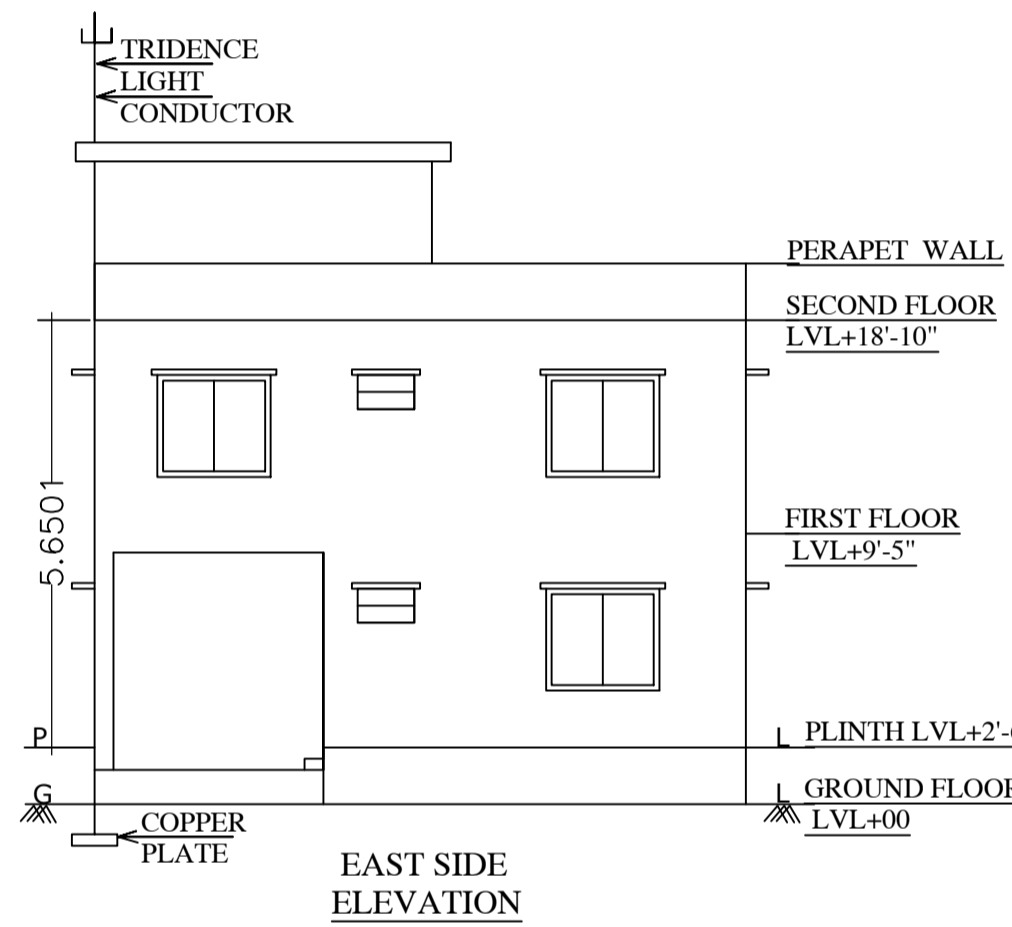

EAST SIDE ELEVATION

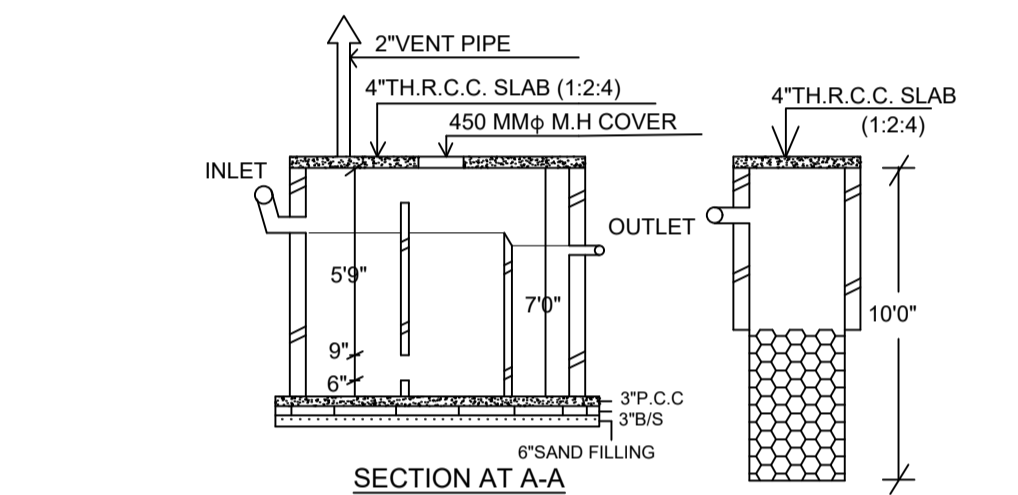

SECTION AT A-A

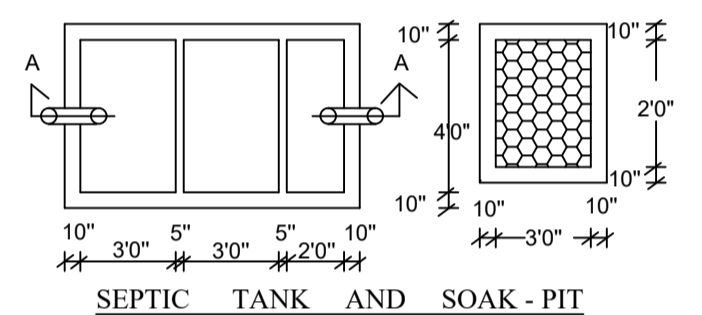

SEPTIC TANK AND SOAK - PIT

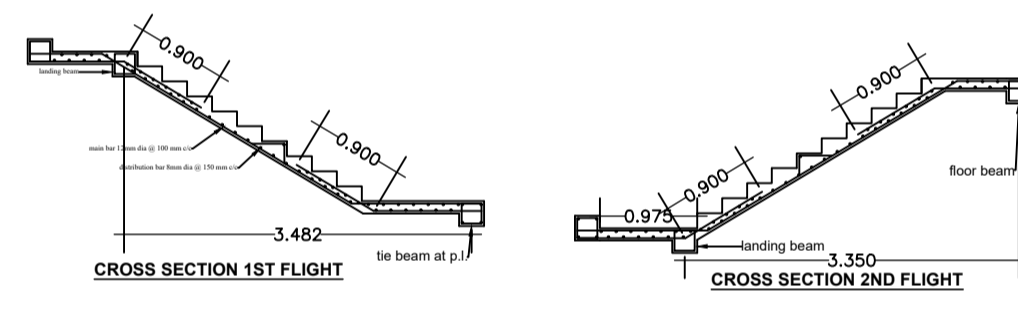

CROSS SECTION 1ST FLIGHT

CROSS SECTION LANDING AND FLIGHT

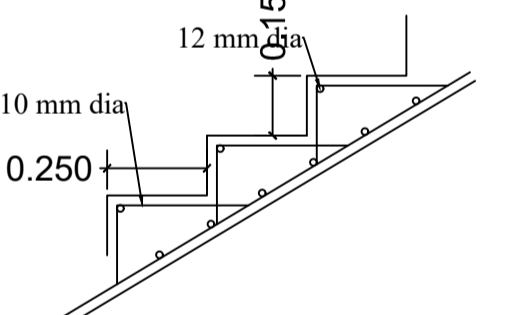

TYPICAL SECTION OF EACH STEP

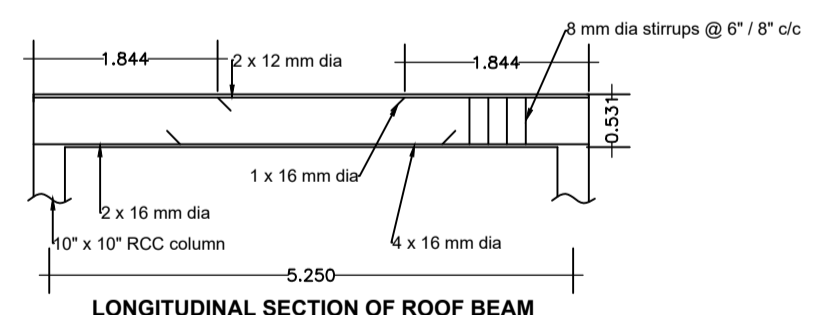

LONGITUDINAL SECTION OF ROOF BEAM

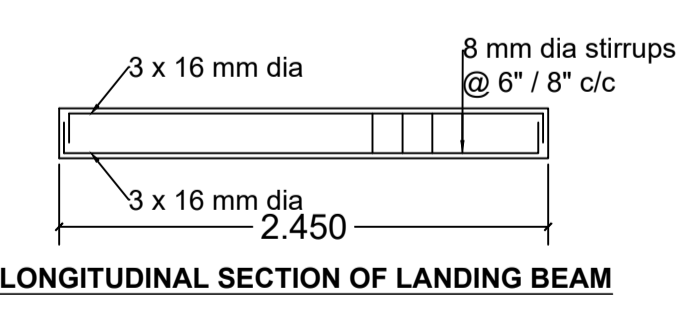

LONGITUDINAL SECTION OF LANDING BEAM

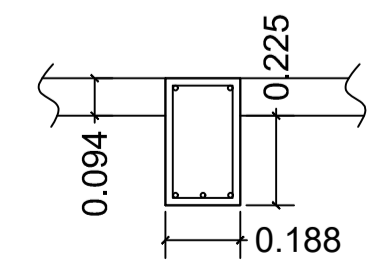

CROSS SECTION OF BEAM AT MIDDLE SPAN

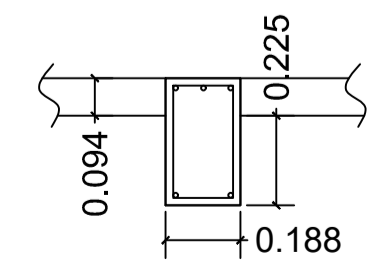

CROSS SECTION OF BEAM AT END SUPPORT

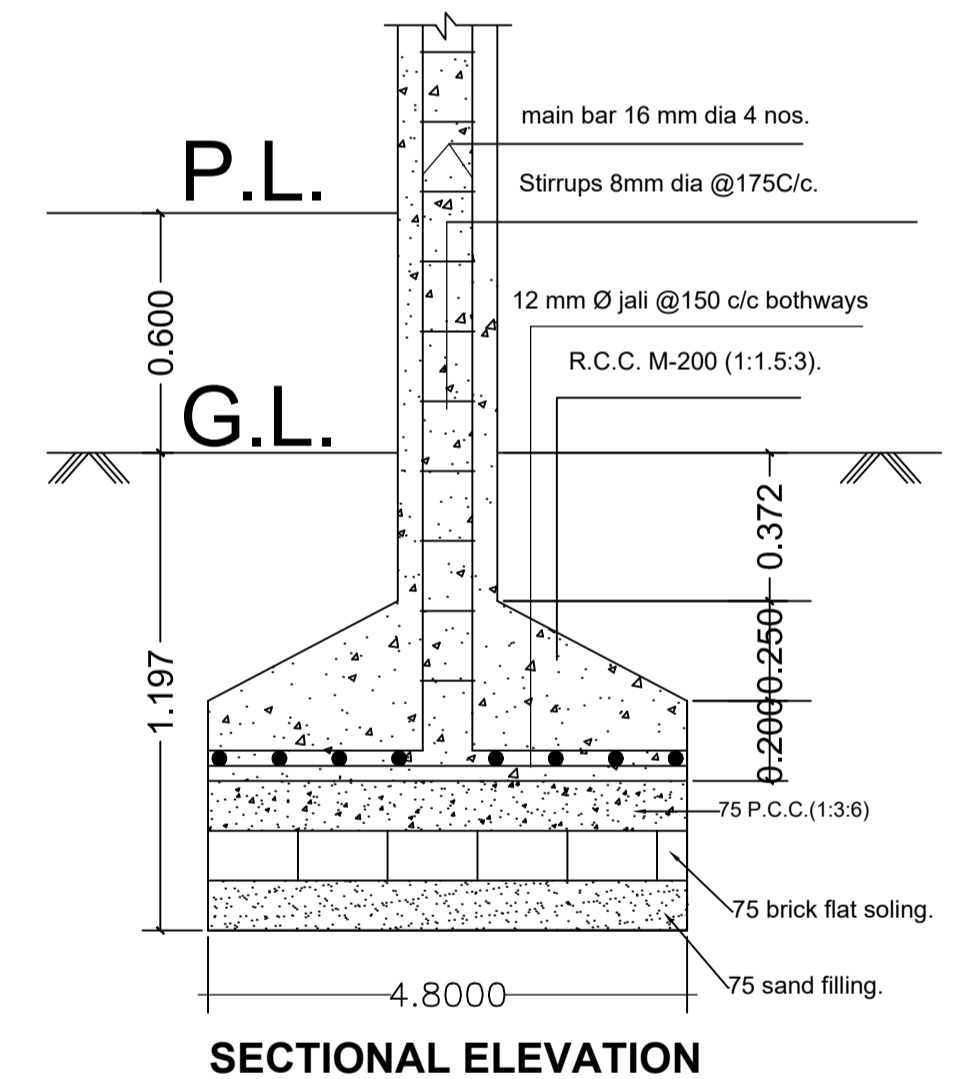

SECTIONAL ELEVATION

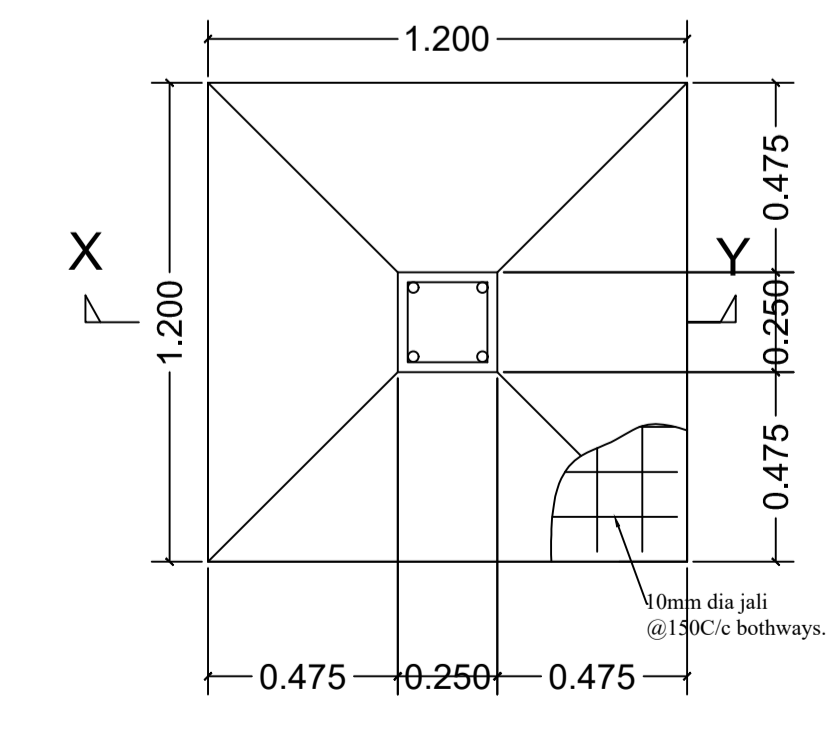

DETAILS OF 250 x 250 R.C.C. COLUMN FOUNDATION

1:50

SCHEDULE OF DOOR:

BUILDING NAME	NAME	LENGTH	HEIGHT	NOS
A (BRAJESH KUMAR TIWARI)	D2	0.75	2.10	02
A (BRAJESH KUMAR TIWARI)	D	1.05	2.10	06

SCHEDULE OF WINDOW/VENTILATION:

BUILDING NAME	NAME	LENGTH	HEIGHT	NOS
A (BRAJESH KUMAR TIWARI)	HLW	0.90	0.60	02
A (BRAJESH KUMAR TIWARI)	W4	1.20	1.50	02
A (BRAJESH KUMAR TIWARI)	W5	1.50	1.35	05
A (BRAJESH KUMAR TIWARI)	W8	2.40	1.35	02

Building :A (BRAJESH KUMAR TIWARI)

Floor Name	Total Built Up Area (Sq.mt.)	Deductions (Area in Sq.mt.)	Proposed FAR Area (Sq.mt.)	Total FAR Area (Sq.mt.)	Total Consumed Additional FAR Area (Sq.mt.)	Tnmt (No.)
Ground Floor	79.95	17.04	62.91	62.91	62.91	01
First Floor	62.91	0.00	62.91	62.91	62.91	00
Terrace Floor	0.00	0.00	0.00	0.00	0.00	00
Total:	142.86	17.04	125.82	125.82	125.82	01
Total Number of Same Buildings	1					
Total :	142.86	17.04	125.82	125.82	125.82	01

UnitBUA Table for Building :A (BRAJESH KUMAR TIWARI)

FLOOR	Name	UnitBUA Type	UnitBUA Area	Carpet Area	No. of Rooms	No. of Tenement
GROUND FLOOR PLAN	SPLIT FLAT-A	FLAT	82.66	79.30	4	1
FIRST FLOOR PLAN	SPLIT FLAT-A	FLAT	0.00	0.00	5	0
Total:	-	-	82.66	79.30	9	1

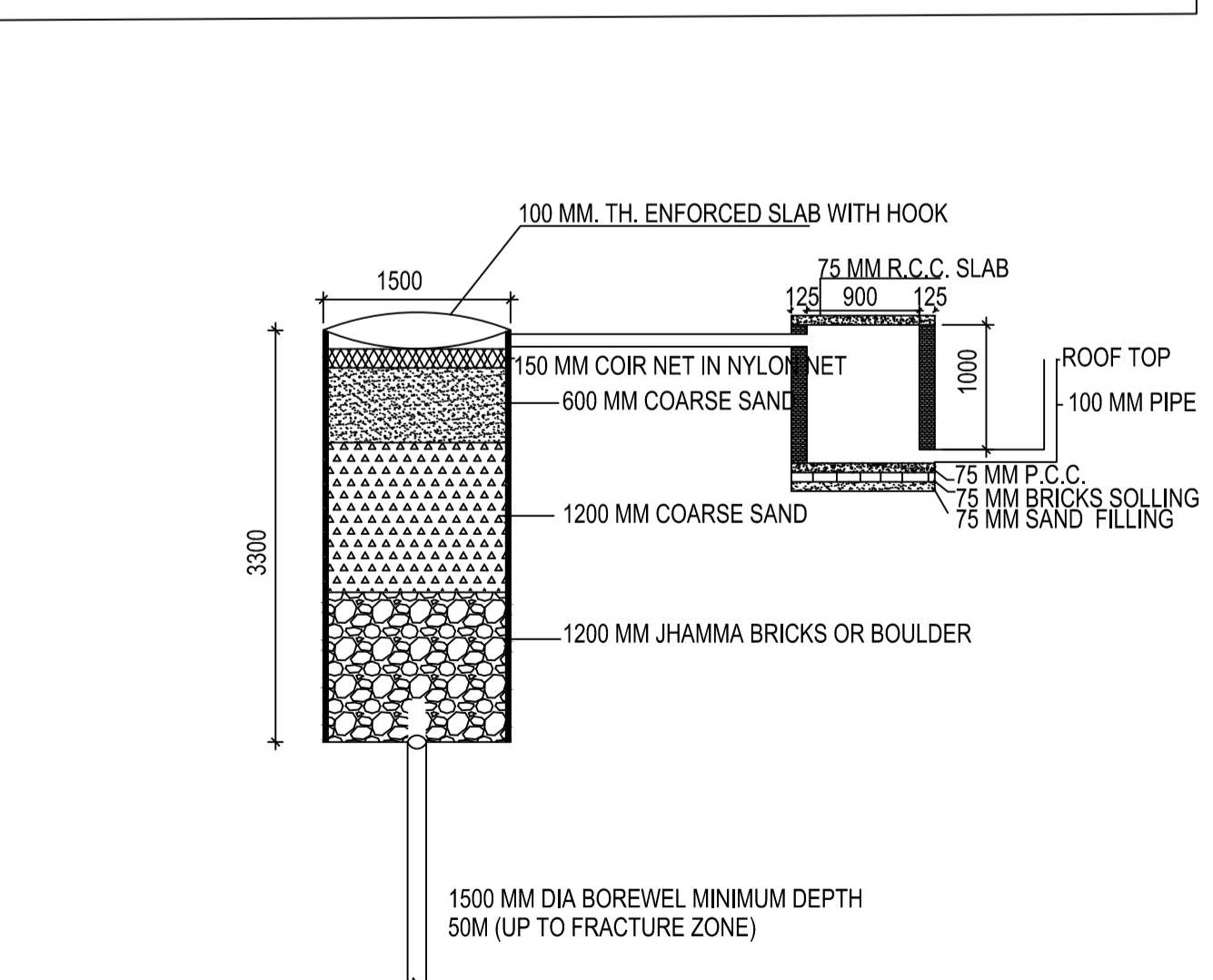
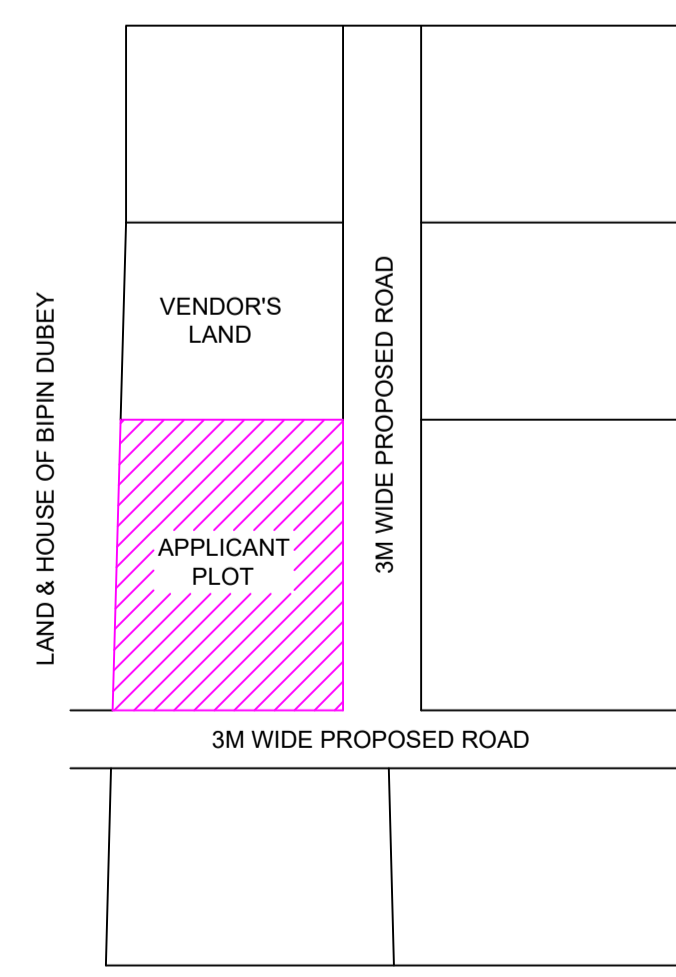

DETAIL OF GROUND WATER RECHARGING PIT WITH SILT TANK

SCALE - N.T.S.

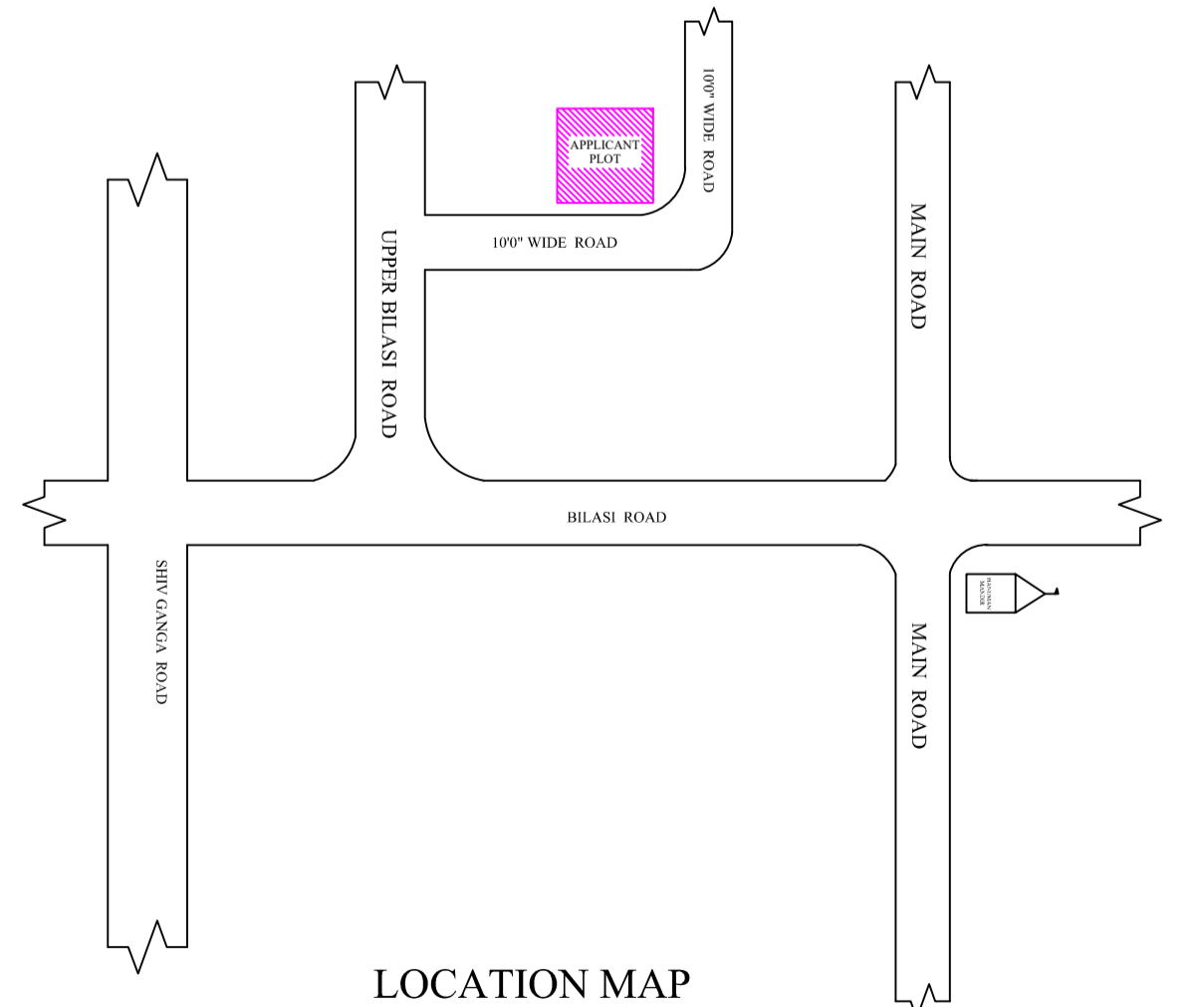

LOCATION MAP

LTP NAME AND SIGNATURE	STRUCTURAL ENG'S NAME AND SIGNATURE	BUILDER NAME AND SIGNATURE
ALOK KUMAR SINGH DGMC/ENG/007/2017		