

LONGITUDINAL SECTION OF LANDING BEAM

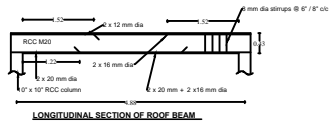

LONGITUDINAL SECTION OF ROOF BEAM

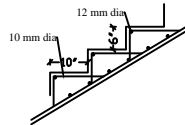

TYPICAL SECTION OF EACH STEP

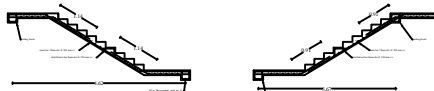

LONGITUDINAL SECTION 1ST FLIGHT

LONGITUDINAL SECTION 2ND FLIGHT

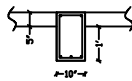

CROSS SECTION OF BEAM AT MIDDLE SPAN

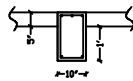

CROSS SECTION OF BEAM AT END SUPPORT

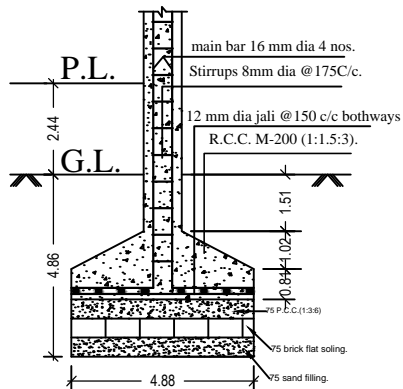

SECTIONAL ELEVATION

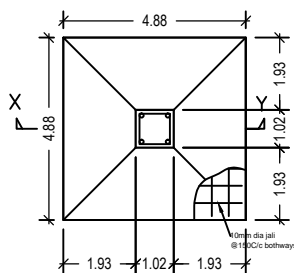

DETAILS OF 250 x 250 R.C.C. COLUMN FOUNDATION
1:50