

Proposal Basic Information	
Proposal File No.	DGMC/BP/0017/W22/2019
Owner Name	MITHILESH KUMAR SINHA
Khata No	386/1
Plot No	28/A
Village Name	Deoghar
Use	Residential
SubUse	Bungalow/ Dwelling / Non Apartment

AREA STATEMENT DEOGHAR MUNICIPAL CORPORATION	VERSION NO.: 1.0.42 VERSION DATE: 29/04/2019
PROJECT DETAIL:	
Region: JHARKHAND URBAN LOCAL BODIES	Plot Use: Residential
District: DEOGHAR	Plot SubUse: Bungalow/ Dwelling / Non Apartment
Authority: DEOGHAR MUNICIPAL CORPORATION	PlotNearby/ReligiousStructure: NA
Inward No: DGMC/BP/0017/W22/2019	Plot/SubPlot No: 28/A
Application Type: General Proposal	North: Plot No. - VENDORS LAND & PART OF S.P PLOT NO.-15
Project Type: Building Permission	South: Road Width - 5.18 M WIDE ROAD
Nature of Development: New	East: Road Width - 4.57 M WIDE ROAD
Location of Development Area: Old Area	West: Plot No. - SUB PLOT NO. 14
AREA DETAILS: SQ.MT.	
AREA OF PLOT (Minimum)	(A) 230.70
Deduction for NetPlot Area	
Surrender Free of Cost	4.15
Total	4.15
NET AREA OF PLOT(Gross Plot Area - Deduction from Gross Plot area)	(A-Deductions) 226.56
Deduction for Balance Plot Area(from Gross Plot Area)	
Surrender Free of Cost	4.15
Common Plot	27.30
Total	31.45
BALANCE AREA OF PLOT(Net Plot Area - Recreational/Amenity spaces)	(A-Deductions) 199.25
PLOT AREA FOR COVERAGE(Net Plot Area)	(A-Deductions) 226.56
Plot Area for FAR (Net Plot Area + RoadWidening Area)	(A-Deductions) 230.70
COVERAGE CHECK	
Permissible Coverage area (70.00 %)	158.59
Proposed Coverage Area (59.22 %)	134.16
Total Prop. Coverage Area (59.22 %)	134.16
Balance coverage area (10.78 %)	24.43
FAR CHECK	
Perm. FAR Area (1.50)	346.05
Total Perm. FAR area	346.05
Residential FAR	320.71
Proposed FAR Area	320.71
Total Proposed FAR Area	320.71
Consumed FAR (Factor)	1.39
Balance FAR Area	25.34
BUILT UP AREA CHECK	
Total Proposed BuiltUp Area	347.09
ARCHITECT (Regd)	ALOK KUMAR SINGH
ENGINEER (Regd)	
SUPERVISOR (Regd)	
OWNER (Regd)	MITHILESH KUMAR SINHA
DEVELOPMENT AUTHORITY LOCAL BODY	

Buildingwise Floor FAR Details

Floor Name	Building Name		Total	
	A (MITHILESH KUMAR SINHA)		Total Proposed Built Up Area (Sq.mt.)	Total FAR Area (Sq.mt.)
Ground Floor	134.15	107.77	134.15	107.77
First Floor	134.16	134.16	134.16	134.16
Second Floor	78.78	78.78	78.78	78.78
Terrace Floor	0.00	0.00	0.00	0.00
Total :	347.09	320.71	347.09	320.71

COLOR INDEX

PLOT BOUNDARY	
ABUTTING ROAD	
PROPOSED CONSTRUCTION	
COMMON PLOT	
ROAD WIDENING AREA	
EXISTING (To be retained)	
EXISTING (To be demolished)	

FAR & Tenement Details (Table 4c-1)

Building	No. of Same Bldg	Total Built Up Area (Sq.mt.)	Deductions (Area in Sq.mt.)		Proposed FAR Area (Sq.mt.)	Total FAR Area (Sq.mt.)	Total Consumed Additional FAR Area (Sq.mt.)	Trmnt (No.)
			Parking	Resi.				
A (MITHILESH KUMAR SINHA)	1	347.09	26.38		320.71	320.71	320.71	01
Grand Total :	1	347.09	26.38		320.71	320.71	320.71	01

Building USE/SUBUSE Details

Building Name	Building Use	Building SubUse	Building Structure
A (MITHILESH KUMAR SINHA)	Residential	Bungalow/ Dwelling / Non Apartment	Non-Highrise

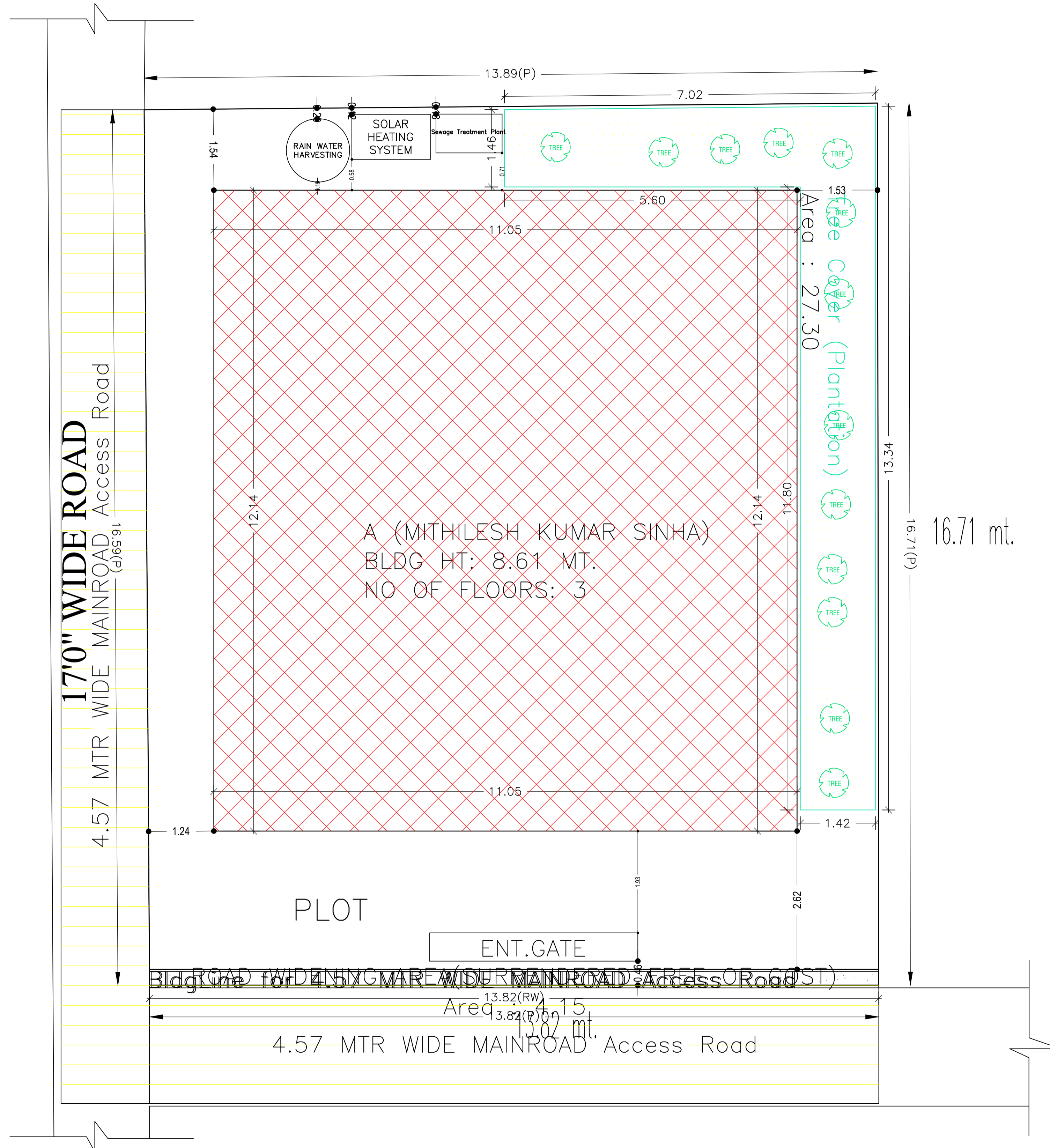

SITE PLAN

LTP NAME AND SIGNATURE	STRUCTURAL ENG'S NAME AND SIGNATURE	BUILDER NAME AND SIGNATURE	DIGITAL SIGNATURE
ALOK KUMAR SINGH DGMC/ENG/0007/2017			

Proposal Basic Information	
Proposal File No.	DGMC/BP/0017/W22/2019
Owner Name	MITHILESH KUMAR SINHA
Khata No	386/1
Plot No	28/A
Village Name	Deoghar
Use	Residential
SubUse	Bungalow/ Dwelling / Non Apartment

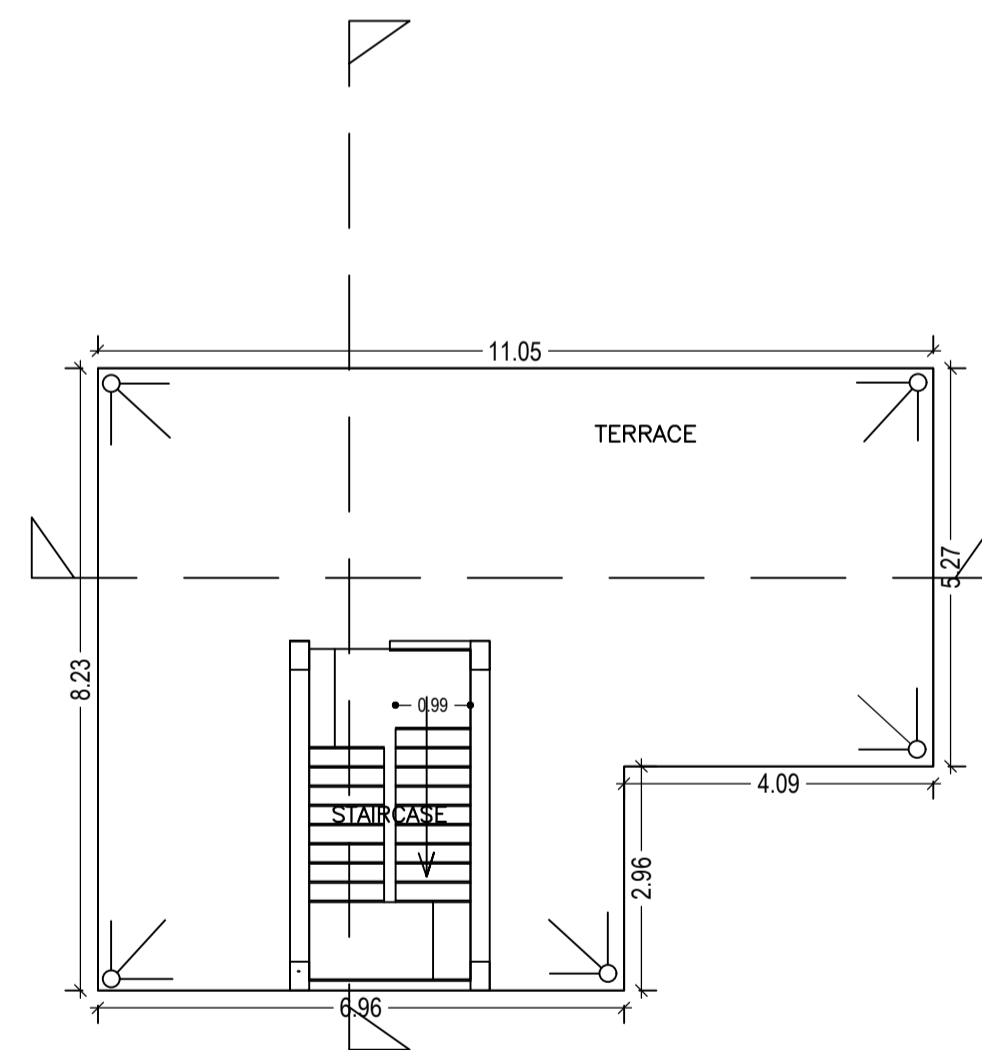
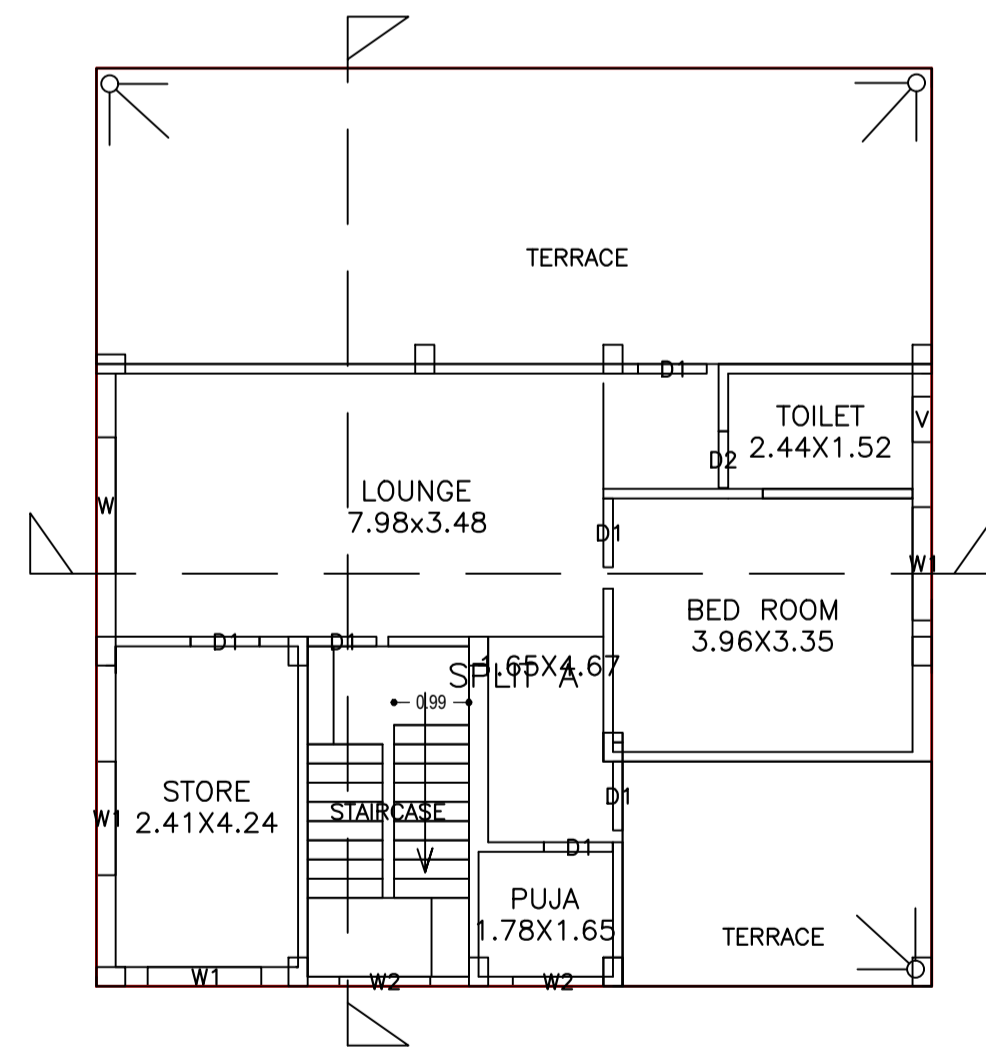
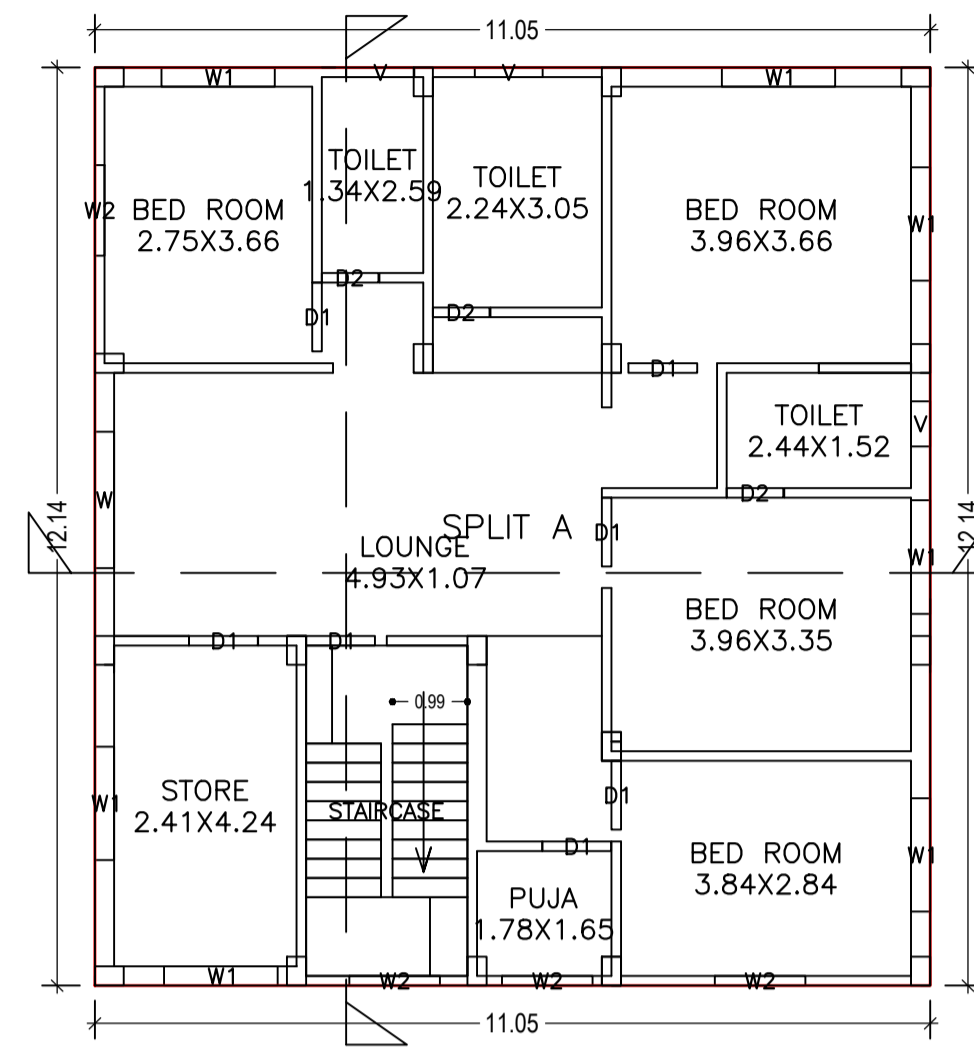
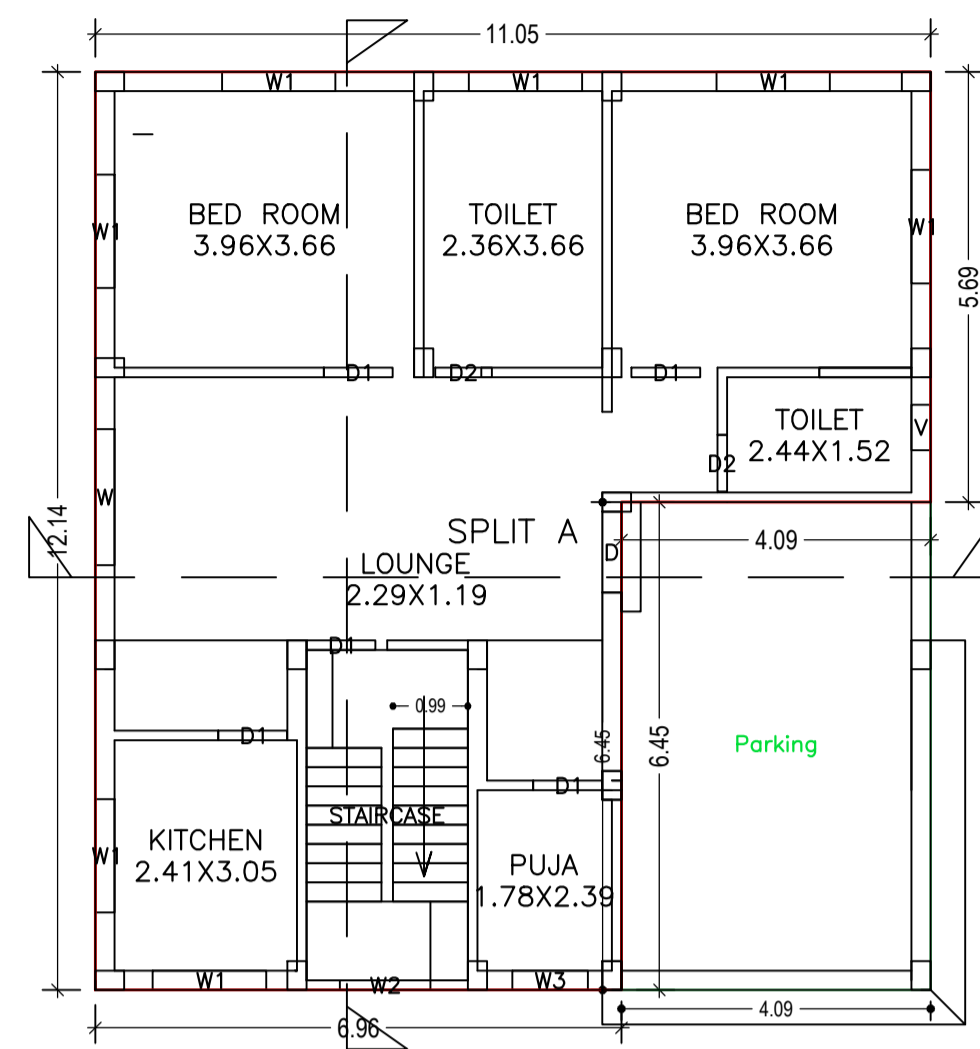

Building :A (MITHILESH KUMAR SINHA)

Floor Name	Total Built Up Area (Sq.mt.)	Deductions (Area in Sq.mt.)	Proposed FAR Area (Sq.mt.)	Total FAR Area (Sq.mt.)	Total Consumed Additional FAR Area (Sq.mt.)	Trmt (No.)
Ground Floor	134.15	26.38	107.77	107.77	107.77	01
First Floor	134.16	0.00	134.16	134.16	134.16	00
Second Floor	78.78	0.00	78.78	78.78	78.78	00
Terrace Floor	0.00	0.00	0.00	0.00	0.00	00
Total :	347.09	26.38	320.71	320.71	320.71	01
Total Number of Same Buildings :	1					
Total :	347.09	26.38	320.71	320.71	320.71	01

SCHEDULE OF DOOR:

BUILDING NAME	NAME	LENGTH	HEIGHT	NOS
A (MITHILESH KUMAR SINHA)	D2	0.75	2.13	06
A (MITHILESH KUMAR SINHA)	D1	0.91	2.13	18
A (MITHILESH KUMAR SINHA)	D	1.07	2.13	01

SCHEDULE OF WINDOW/VENTILATION:

BUILDING NAME	NAME	LENGTH	HEIGHT	NOS
A (MITHILESH KUMAR SINHA)	V	0.60	2.70	03
A (MITHILESH KUMAR SINHA)	V	0.90	2.70	02
A (MITHILESH KUMAR SINHA)	W3	1.00	2.70	01
A (MITHILESH KUMAR SINHA)	W2	1.20	2.70	07
A (MITHILESH KUMAR SINHA)	W1	1.50	2.70	17
A (MITHILESH KUMAR SINHA)	W	1.80	2.70	03

UnitBUA Table for Building :A (MITHILESH KUMAR SINHA)

FLOOR	Name	UnitBUA Type	UnitBUA Area	Carpet Area	No. of Rooms	No. of Tenement
GROUND FLOOR PLAN	SPLIT A	FLAT	260.63	260.07	7	1
FIRST FLOOR PLAN	SPLIT A	FLAT	0.00	0.00	10	0
SECOND FLOOR PLAN	SPLIT A	FLAT	0.00	0.00	5	0
Total:	-	-	260.63	260.07	22	1

LTP NAME AND SIGNATURE	STRUCTURAL ENG'S NAME AND SIGNATURE	BUILDER NAME AND SIGNATURE	DIGITAL SIGNATURE
ALOK KUMAR SINGH DGMC/ENG/0007/2017			

Proposal Basic Information	
Proposal File No.	DGMC/BP/0017/W22/2019
Owner Name	MITHILESH KUMAR SINHA
Khata No	386/1
Plot No	28/A
Village Name	Deoghar
Use	Residential
SubUse	Bungalow/ Dwelling / Non Apartment

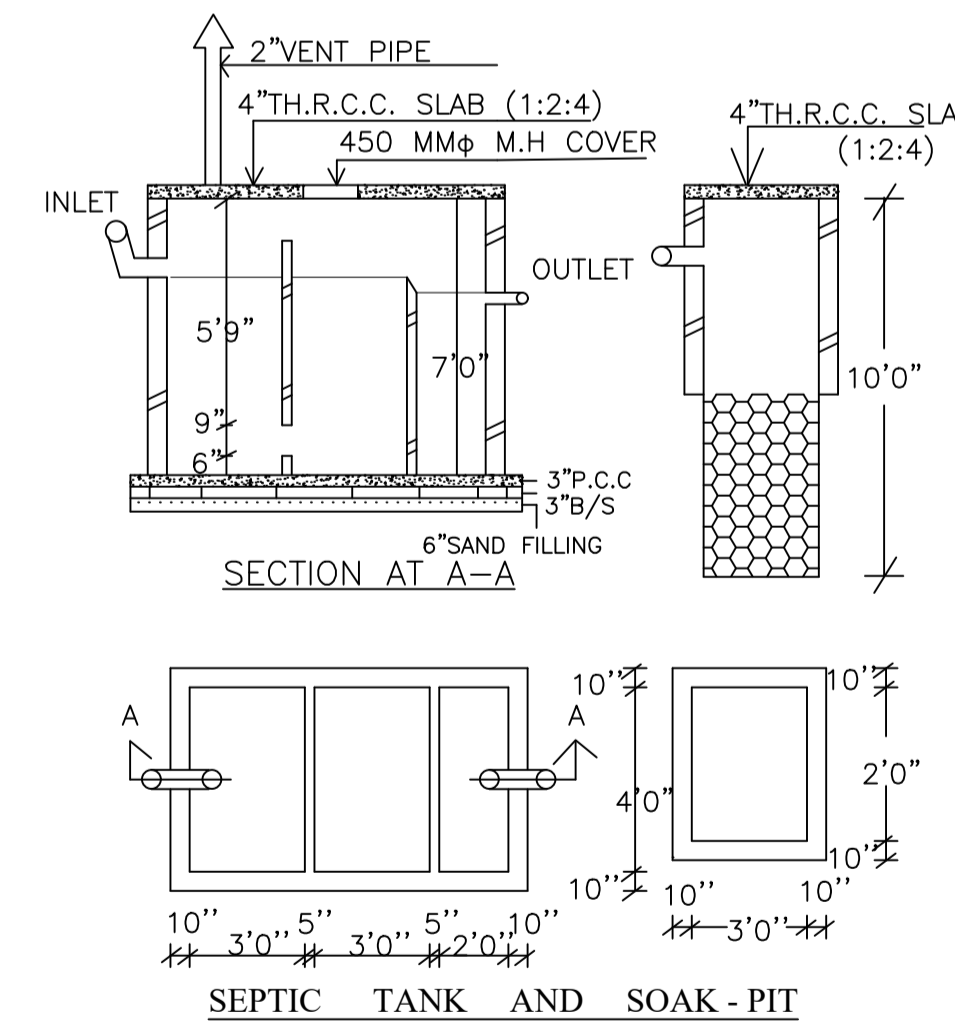
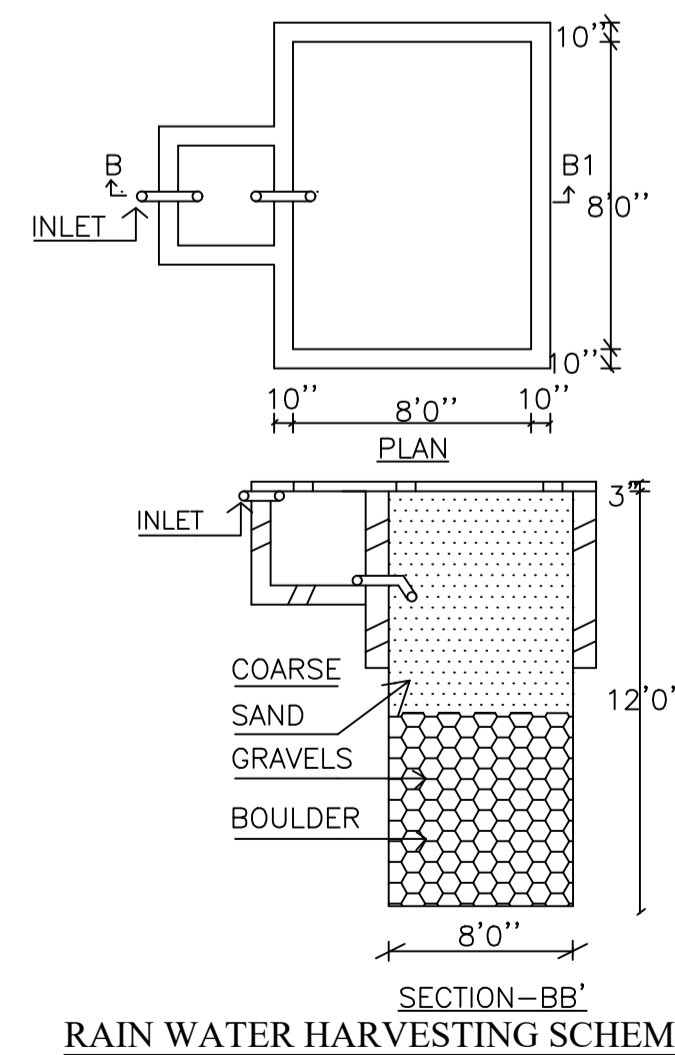
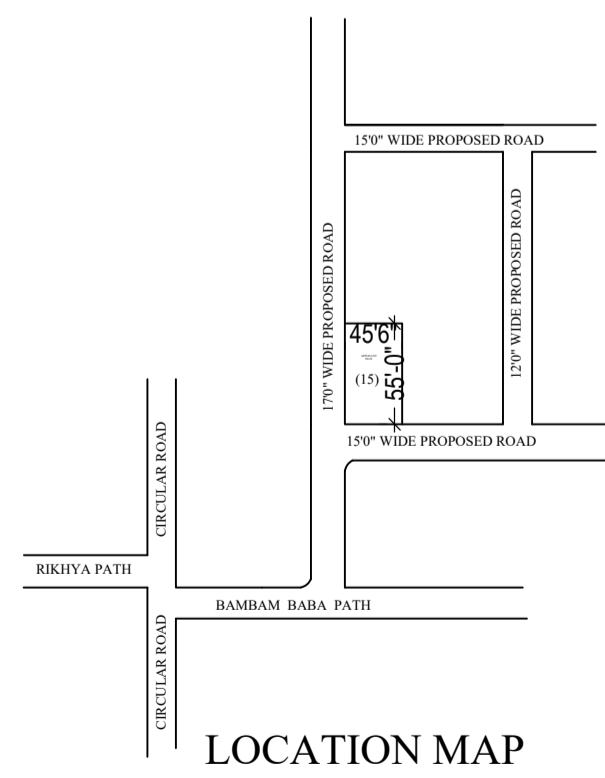
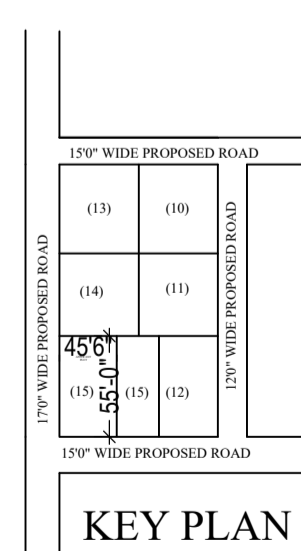
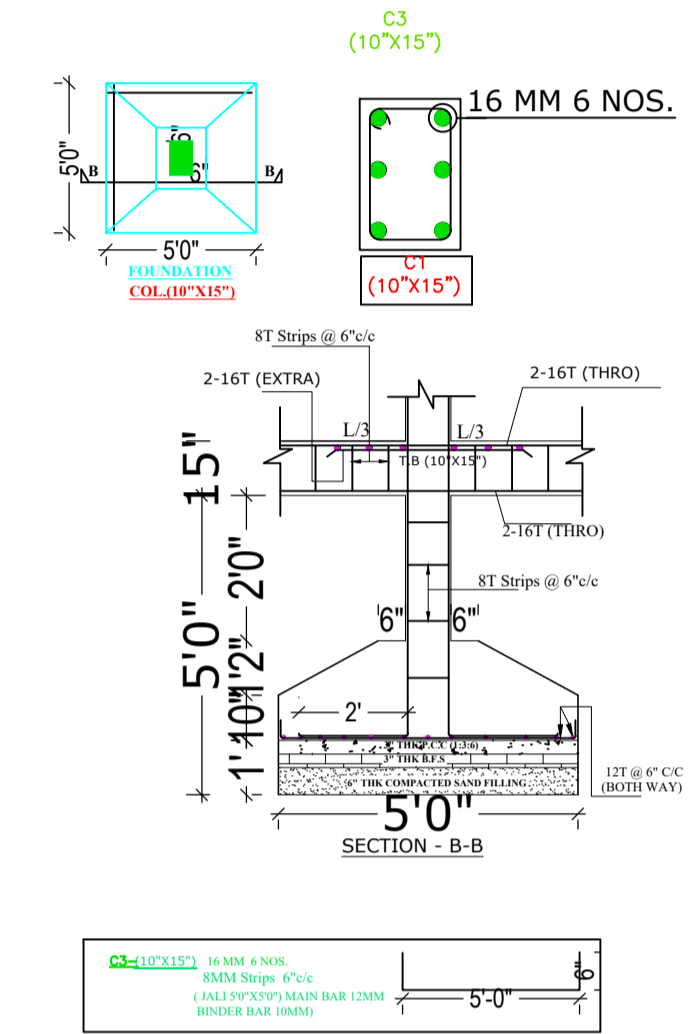
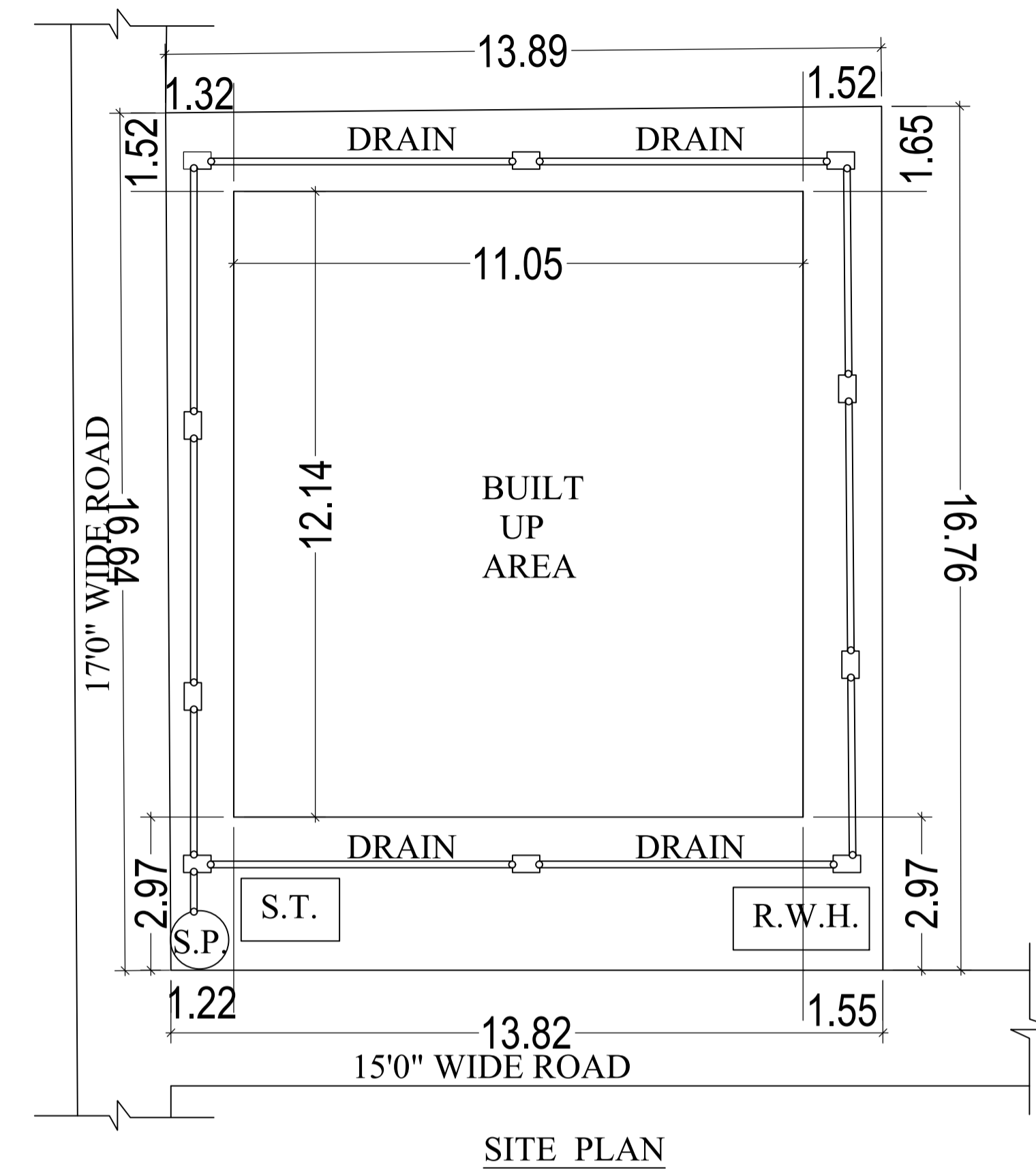
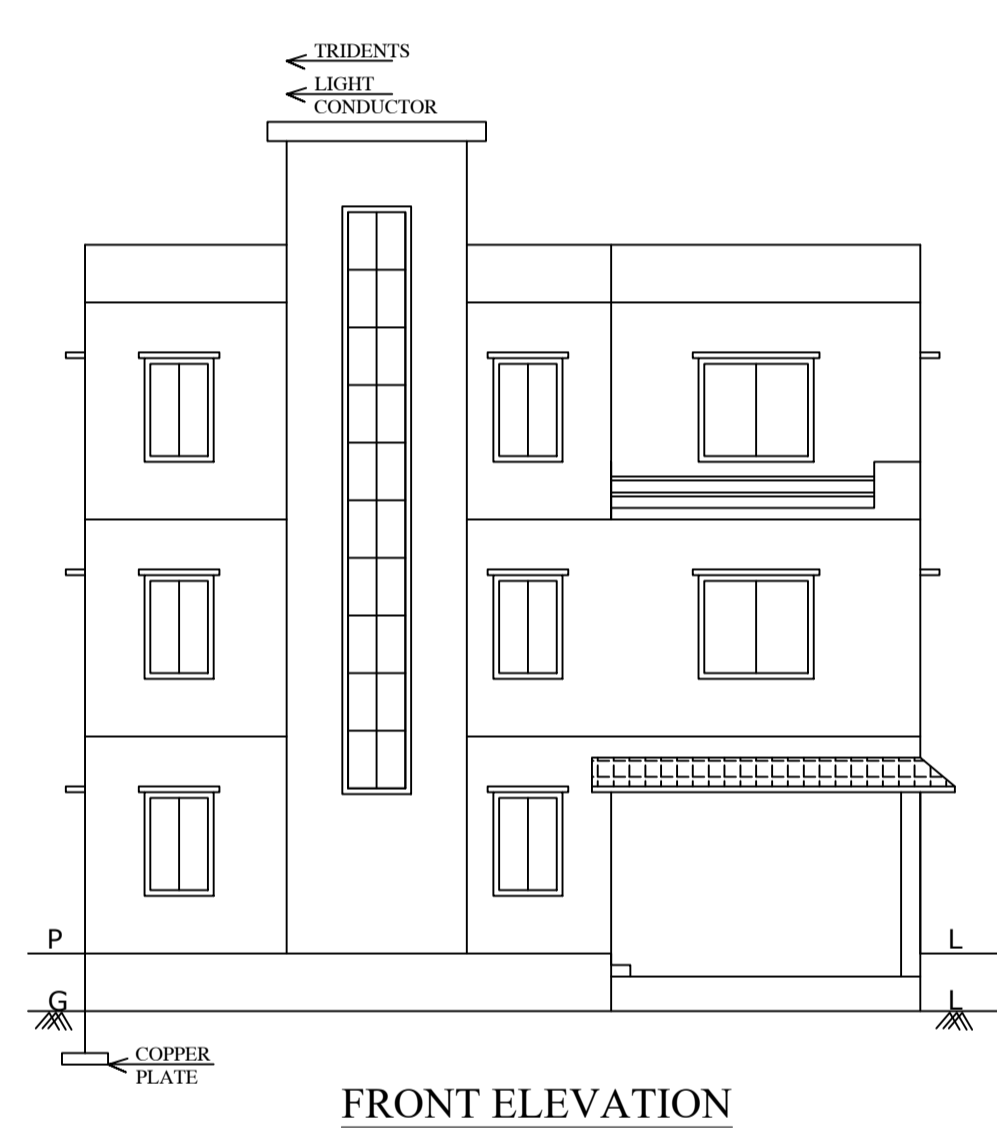
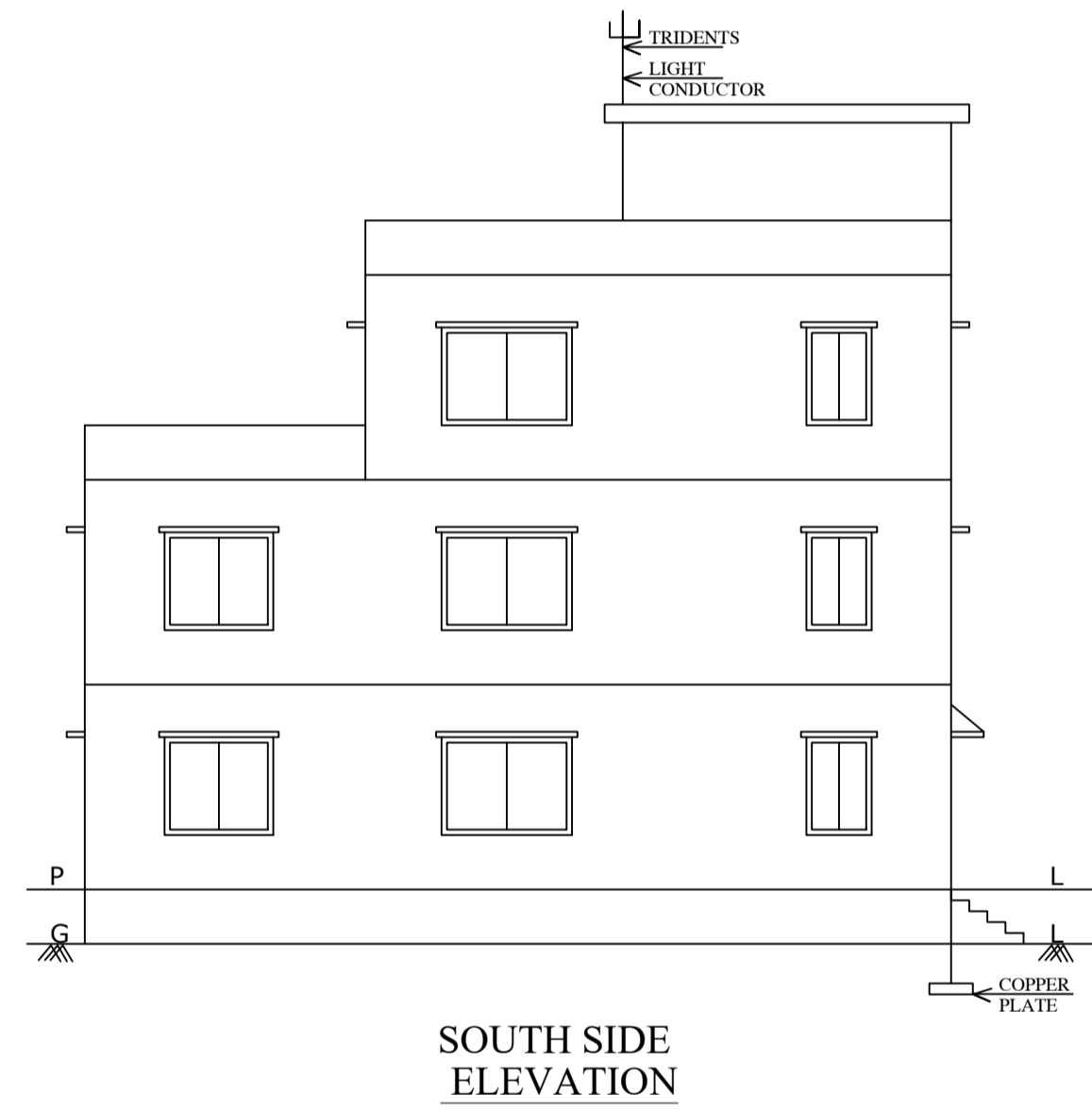
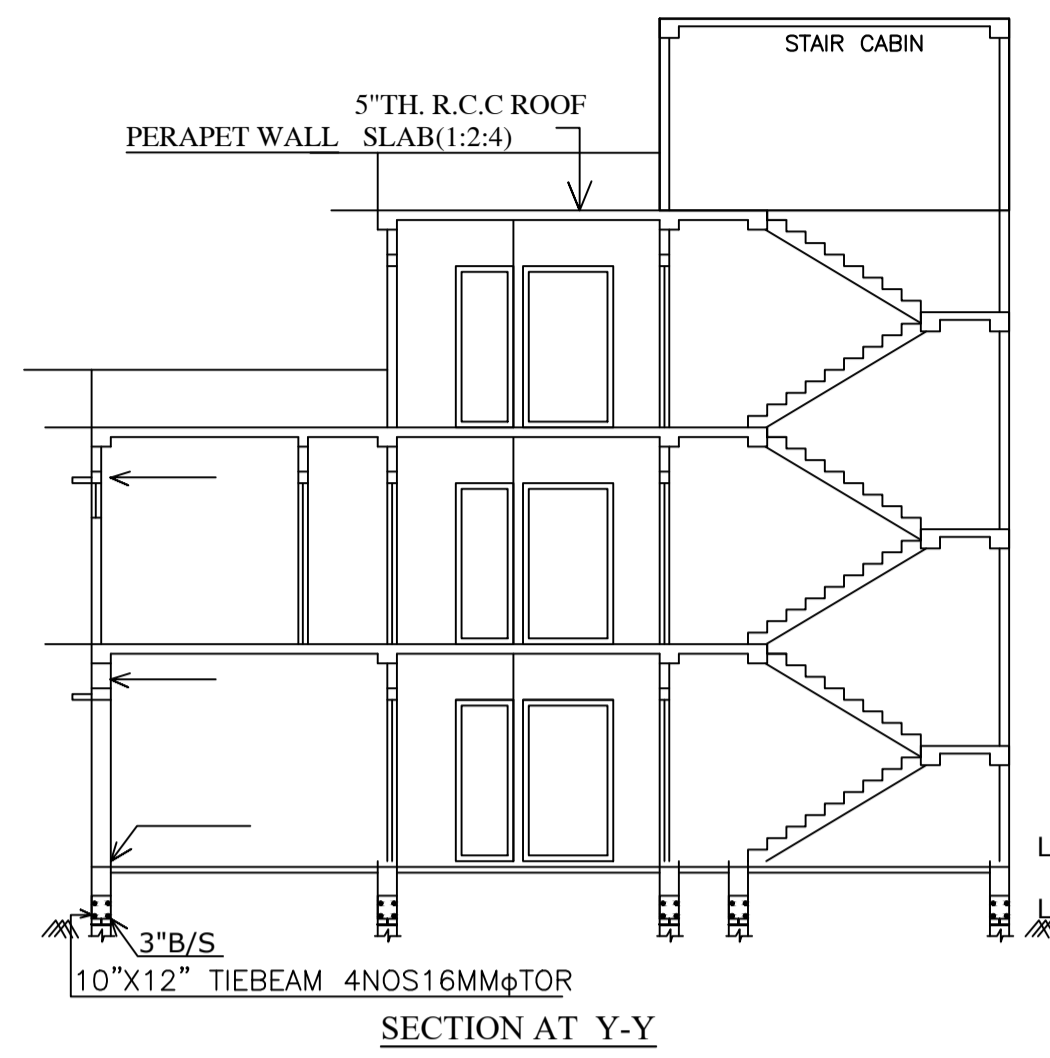
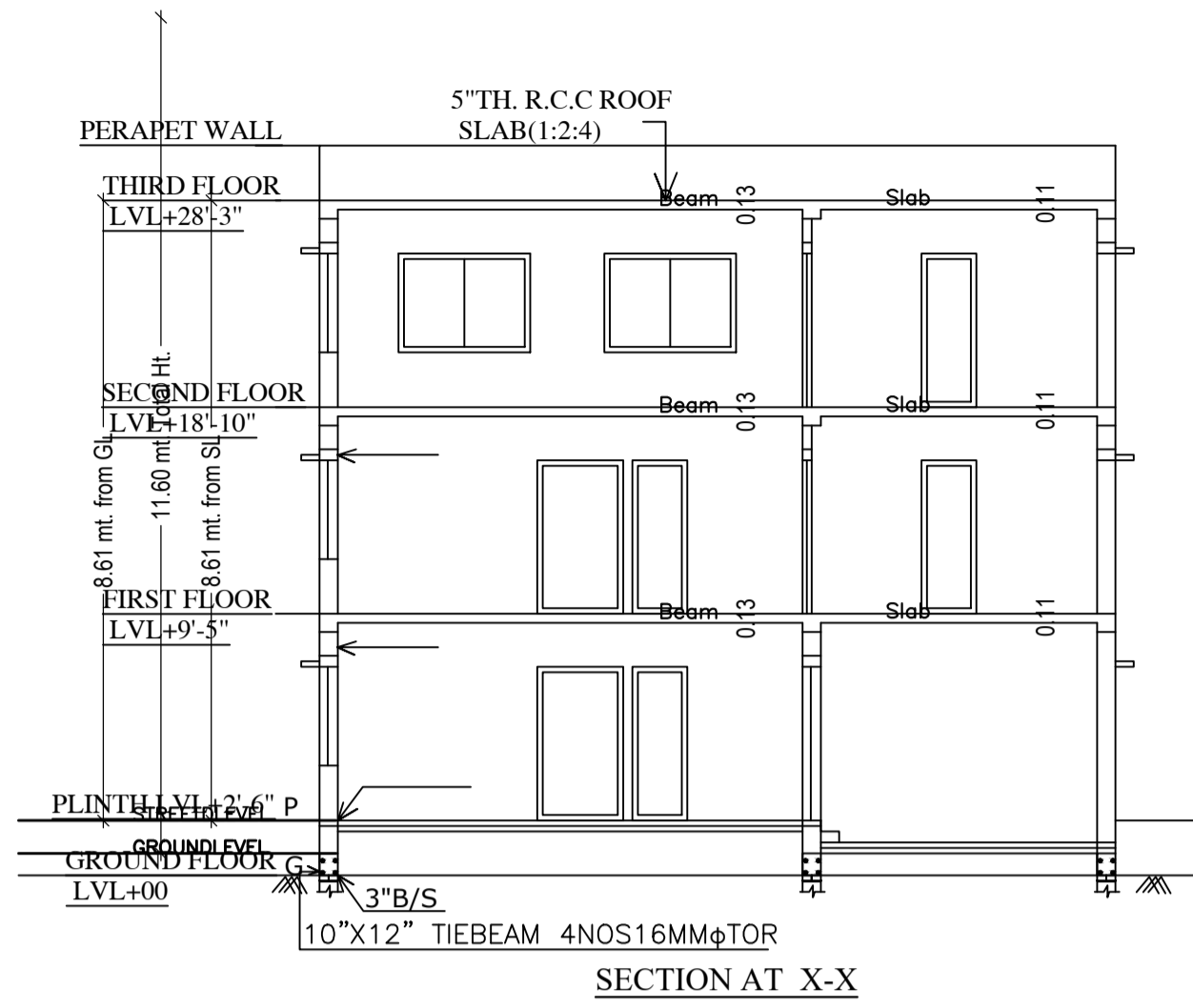

LTP NAME AND SIGNATURE	STRUCTURAL ENG'S NAME AND SIGNATURE	BUILDER NAME AND SIGNATURE	DIGITAL SIGNATURE
ALOK KUMAR SINGH DGMC/ENG/0007/2017			