

SITE PLAN

AREA STATEMENT DEOGHAR MUNICIPAL CORPORATION	VERSION NO.: 1.0.42 VERSION DATE: 29/04/2019
PROJECT DETAIL:	
Region: JHARKHAND URBAN LOCAL BODIES	Plot Use: Residential
District: DEOGHAR	Plot SubUse: Bungalow/ Dwelling / Non Apartment
Authority: DEOGHAR MUNICIPAL CORPORATION	PlotNearby/ReligiousStructure: NA
Inward No: DGMC/0004/2019	Plot/SubPlot No: 740
Application Type: General Proposal	North: -
Project Type: Building Permission	South: -
Nature of Development: New	East: -
Location of Development Area: Old Area	West: -
AREA DETAILS:	
AREA OF PLOT (Minimum)	(A) 196.48 SQ.MT.
Deduction for NetPlot Area	
Surrender Free of Cost	5.07
Total	5.07
NET AREA OF PLOT(Gross Plot Area - Deduction from Gross Plot area)	(A-Deductions) 191.41
Deduction for Balance Plot Area(from Gross Plot Area)	
Surrender Free of Cost	5.07
Common Plot	25.77
Total	30.84
BALANCE AREA OF PLOT(Net Plot Area - Recreational/Amenity space)	(A-Deductions) 165.64
PLOT AREA FOR COVERAGE(Net Plot Area)	(A-Deductions) 191.41
Plot Area for FAR (Net Plot Area + RoadWidening Area)	(A-Deductions) 196.48
COVERAGE CHECK	
Permissible Coverage area (70.00 %)	133.99
Proposed Coverage Area (58.97 %)	112.88
Total Prop. Coverage Area (58.97 %)	112.88
Balance coverage area (11.03 %)	21.11
FAR CHECK	
Perm. FAR Area (1.20)	235.78
Total Perm. FAR area	235.78
Residential FAR	226.84
Proposed FAR Area	226.84
Total Proposed FAR Area	226.84
Consumed FAR (Factor)	1.15
Balance FAR Area	8.94
BUILT UP AREA CHECK	
Total Proposed BuiltUp Area	246.87
ARCHITECT (Regd)	YAMUNA PRASAD LACHHIRAMKA
ENGINEER (Regd)	
SUPERVISOR (Regd)	
OWNER (Regd)	SMT. SIMMI KUMARI
DEVELOPMENT AUTHORITY LOCAL BODY	

COLOR INDEX	
PLOT BOUNDARY	Black
ABUTTING ROAD	Green
PROPOSED CONSTRUCTION	Red
COMMON PLOT	Blue
ROAD WIDENING AREA	Yellow
EXISTING (To be retained)	Light Blue
EXISTING (To be demolished)	Light Yellow

Buildingwise Floor FAR Details

Floor Name	Building Name		Total	
	Proposed Built Up Area (Sq.mt.)	Proposed FAR Area (Sq.mt.)	Total Proposed Built Up Area (Sq.mt.)	Total FAR Area (Sq.mt.)
Basement Floor	112.88	112.88	112.88	112.88
Ground Floor	77.95	57.93	77.95	57.93
First Floor	56.04	56.04	56.04	56.04
Terrace Floor	0.00	0.00	0.00	0.00
Total :	246.87	226.85	246.87	226.85

Building USE/SUBUSE Details

Building Name	Building Use	Building SubUse	Building Structure
A (SMT SIMMI KUMARI)	Residential	Bungalow/ Dwelling / Non Apartment	Non-Highrise

FAR & Tenement Details (Table 4c-1)

Building	No. of Same Bldg	Total Built Up Area (Sq.mt.)	Deductions (Area in Sq.mt.)		Proposed FAR Area (Sq.mt.)	Total FAR Area (Sq.mt.)	Total Consumed Additional FAR Area (Sq.mt.)	Trmt (No.)
			Parking	Resi.				
A (SMT SIMMI KUMARI)	1	246.87	20.02		226.85	226.85	226.85	01
Grand Total :	1	246.87	20.02		226.85	226.85	226.85	01

Proposal Basic Information	
Proposal File No.	DGMC/0004/2019
Owner Name	SMT. SIMMI KUMARI
Khata No	38/3202/3 (PART)
Plot No	740
Village Name	Deoghar
Use	Residential
SubUse	Bungalow/ Dwelling / Non Apartment

LTP NAME AND SIGNATURE	STRUCTURAL ENG'S NAME AND SIGNATURE	BUILDER NAME AND SIGNATURE	DIGITAL SIGNATURE
YAMUNA PRASAD LACHHIRAMKA DGMC/ENG/0013/2017			

Proposal Basic Information

Proposal File No.	DGMC/0004/2019
Owner Name	SMT. SIMMI KUMARI
Khata No	38/3202/3 (PART)
Plot No	740
Village Name	Deoghar
Use	Residential
SubUse	Bungalow/ Dwelling / Non Apartment

Building :A (SMT SIMMI KUMARI)

Floor Name	Total Built Up Area (Sq.mt.)	Deductions (Area in Sq.mt.) Parking	Proposed FAR Area (Sq.mt.) Resi.	Total FAR Area (Sq.mt.)	Total Consumed Additional FAR Area (Sq.mt.)	Tnmt (No.)
Basement Floor	112.88	0.00	112.88	112.88	112.88	01
Ground Floor	77.95	20.02	57.93	57.93	57.93	00
First Floor	56.04	0.00	56.04	56.04	56.04	00
Terrace Floor	0.00	0.00	0.00	0.00	0.00	00
Total :	246.87	20.02	226.85	226.85	226.85	01
Total Number of Same Buildings :	1					
Total :	246.87	20.02	226.85	226.85	226.85	01

SCHEDULE OF DOOR:

BUILDING NAME	NAME	LENGTH	HEIGHT	NOS
A (SMT SIMMI KUMARI)	D2	0.75	2.13	03
A (SMT SIMMI KUMARI)	D1	0.91	2.13	05
A (SMT SIMMI KUMARI)	D1	1.00	2.13	02
A (SMT SIMMI KUMARI)	D	1.07	2.13	01

SCHEDULE OF WINDOW/VENTILATION:

BUILDING NAME	NAME	LENGTH	HEIGHT	NOS
A (SMT SIMMI KUMARI)	V	0.60	2.70	02
A (SMT SIMMI KUMARI)	W1	1.00	2.70	02
A (SMT SIMMI KUMARI)	W2	1.20	2.70	02
A (SMT SIMMI KUMARI)	W	1.80	2.70	05

UnitBUA Table for Building :A (SMT SIMMI KUMARI)

FLOOR	Name	UnitBUA Type	UnitBUA Area	Carpet Area	No. of Rooms	No. of Tenement
BASEMENT FLOOR PLAN	SPLIT A	FLAT	166.01	165.38	1	1
GROUND FLOOR PLAN	SPLIT A	FLAT	0.00	0.00	4	0
FIRST FLOOR PLAN	SPLIT A	FLAT	0.00	0.00	4	0
Total:	-	-	166.01	165.38	9	1

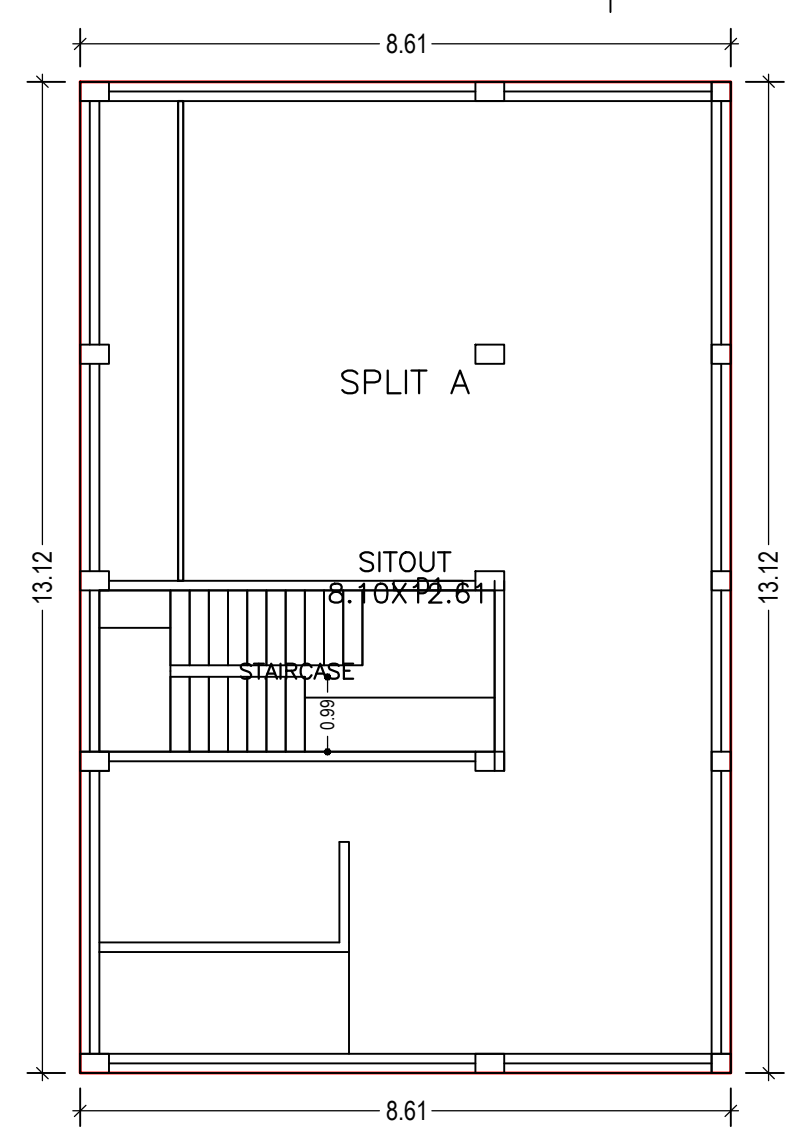

BASEMENT FLOOR PLAN (Proposed) (SCALE 1:100)

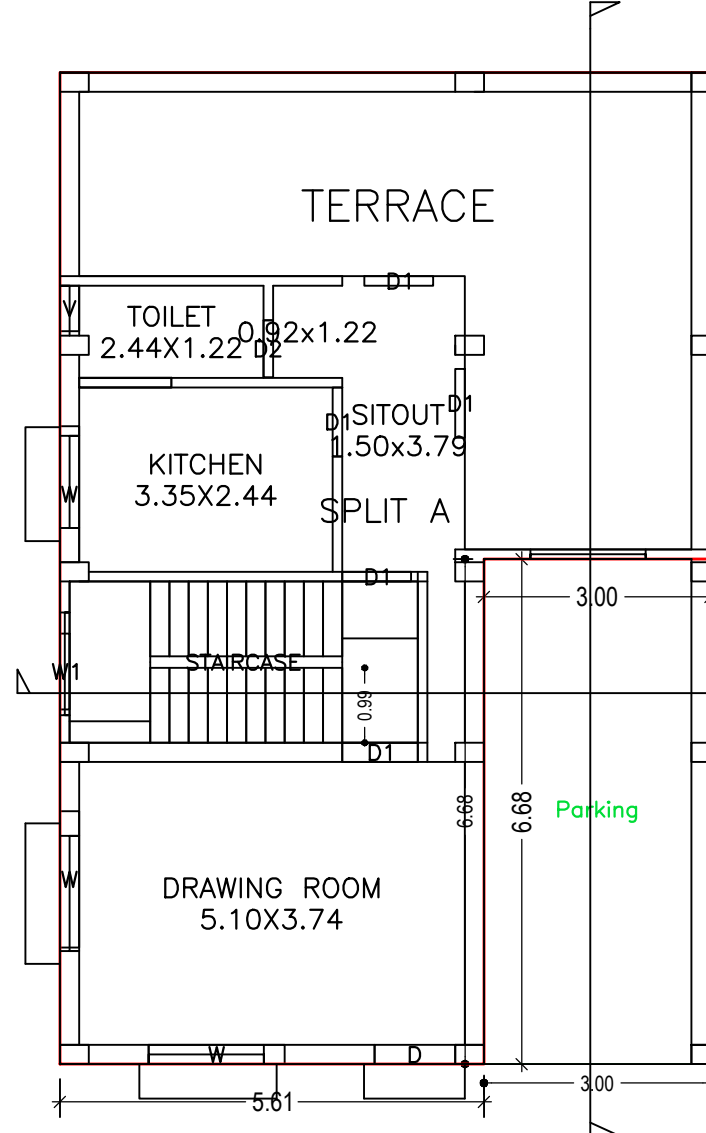

GROUND FLOOR PLAN (Proposed) (SCALE 1:100)

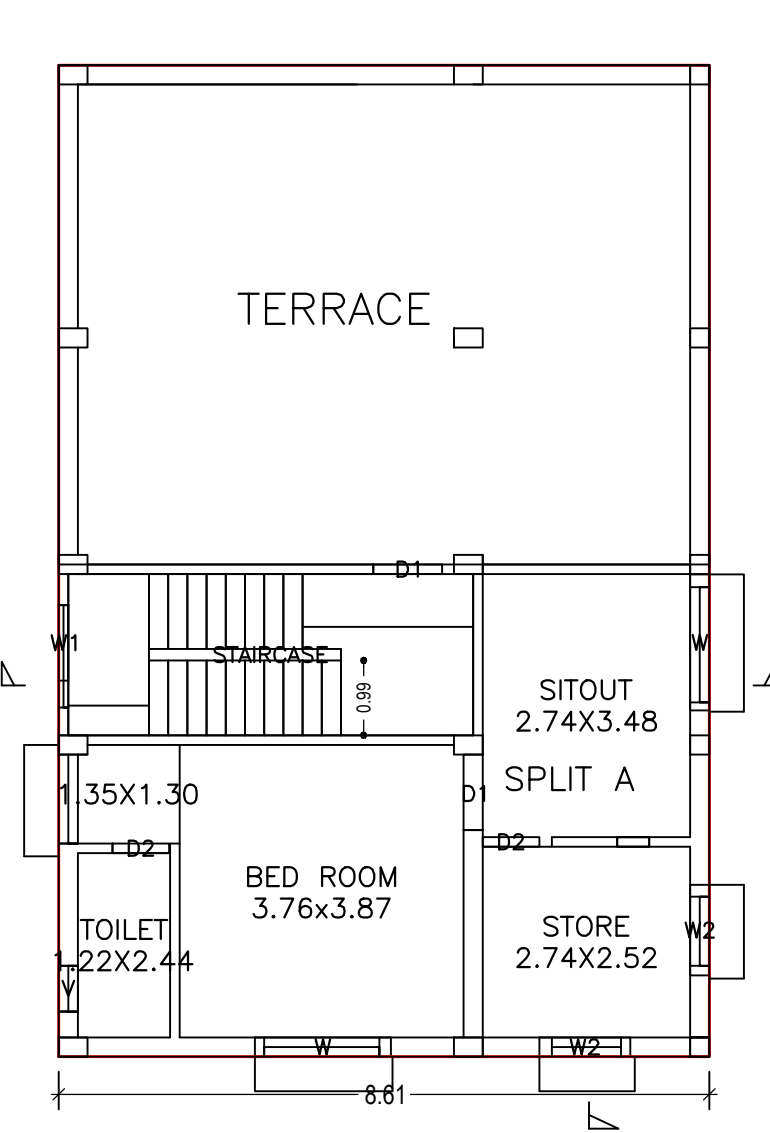

FIRST FLOOR PLAN (Proposed) (SCALE 1:100)

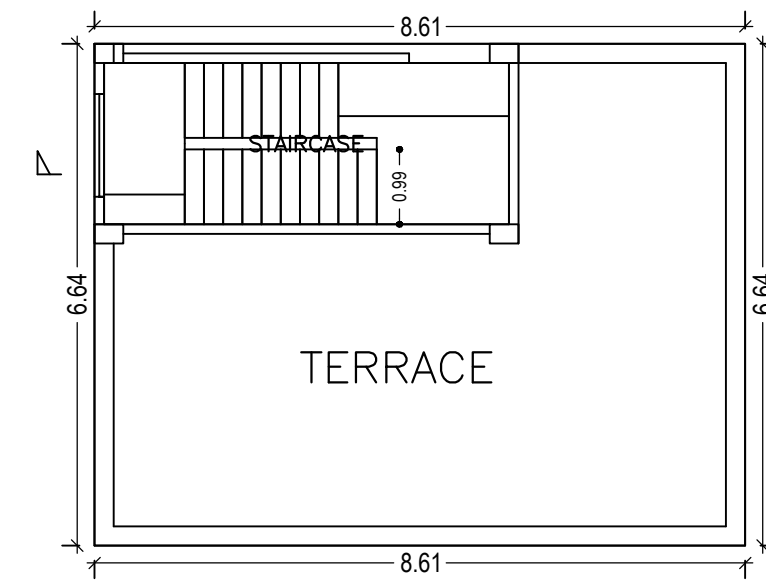

TERRACE FLOOR PLAN (SCALE 1:100)

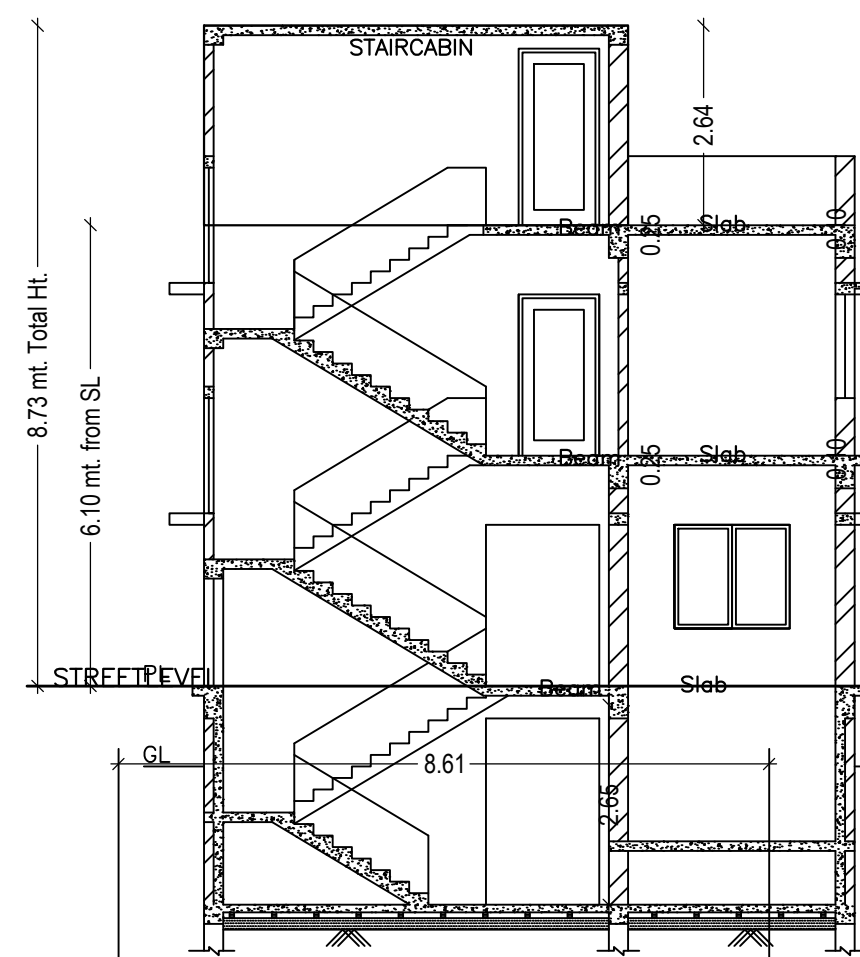

SECTION AT 'A-B'

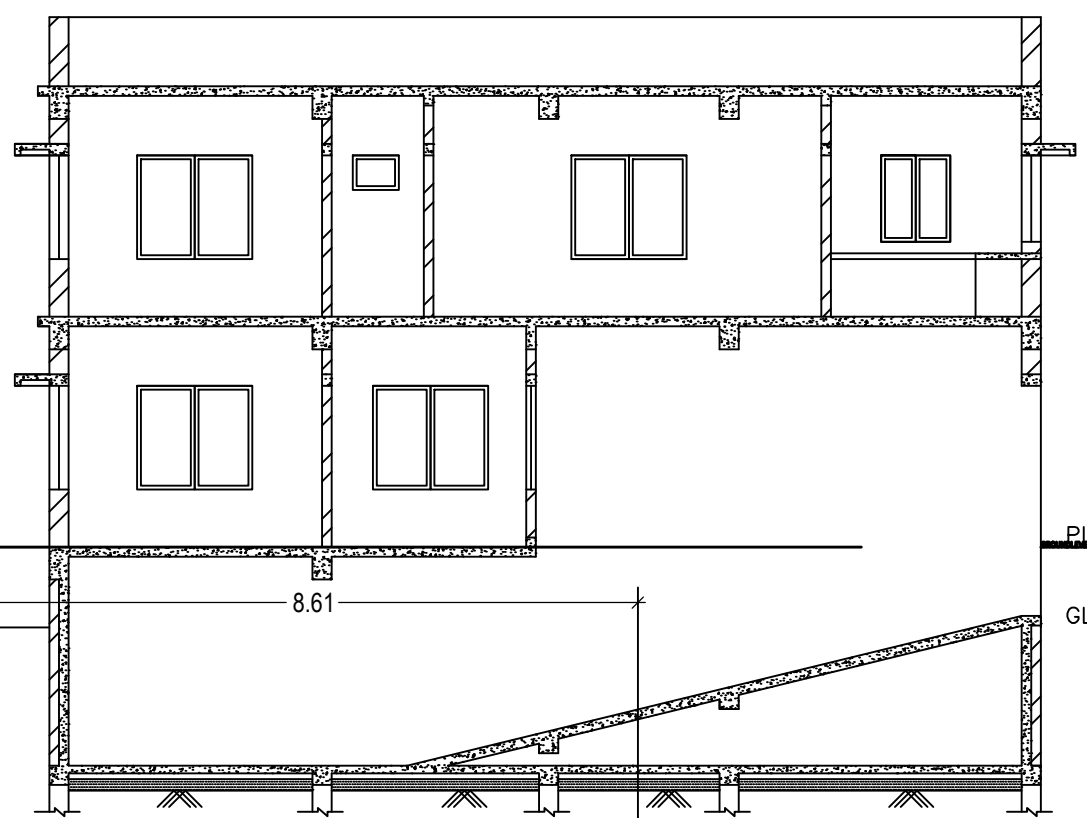

SECTION AT 'C-D'

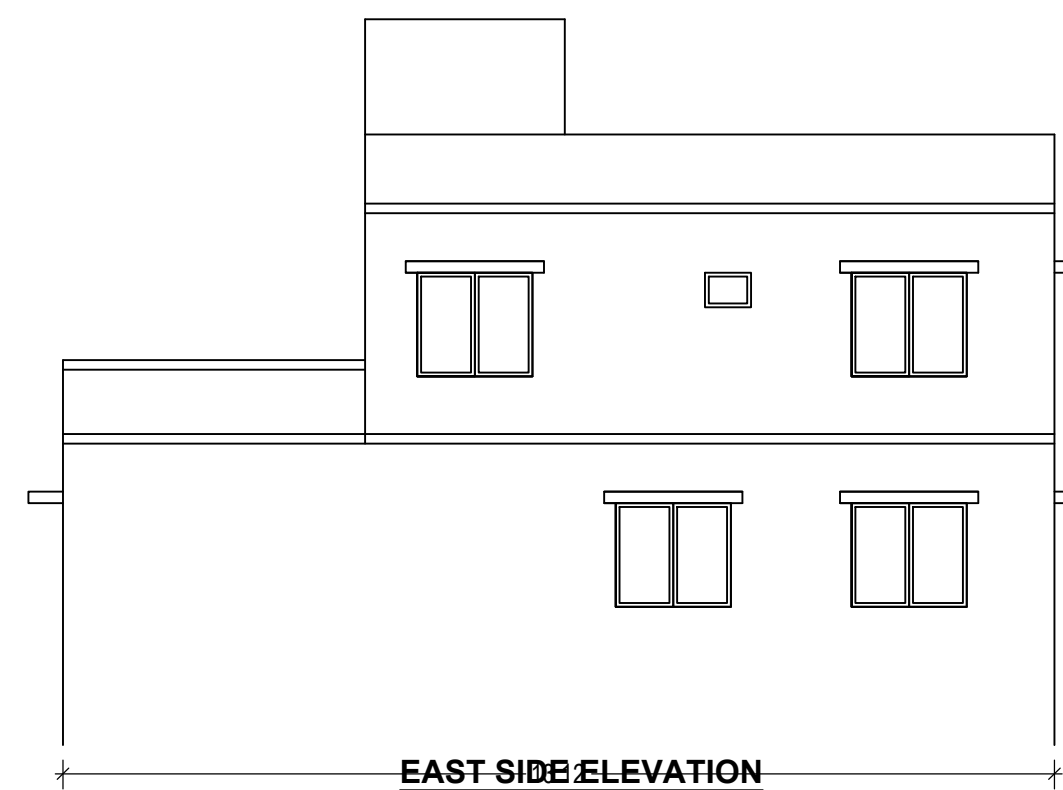

EAST SIDE ELEVATION



SOUTH SIDE ELEVATION

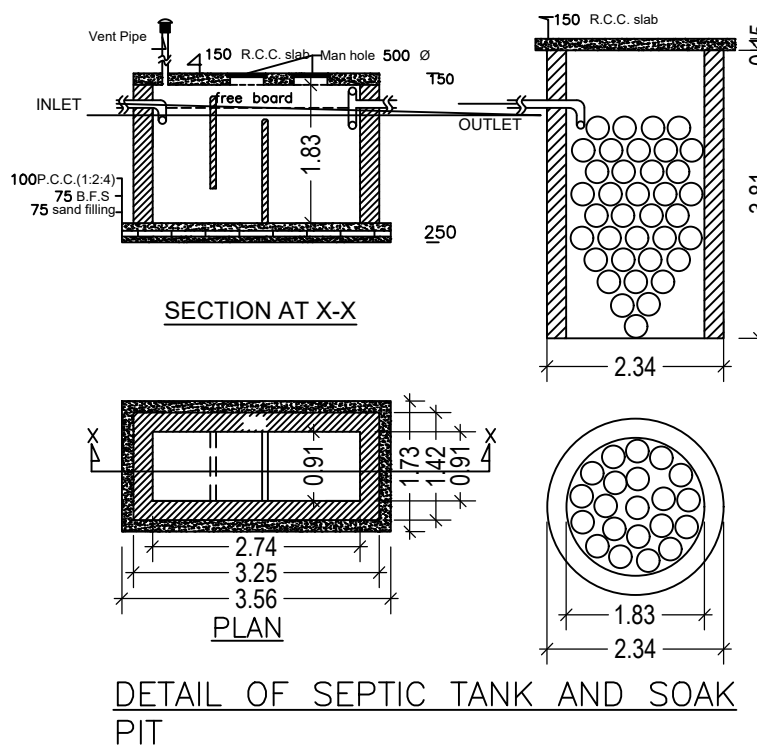
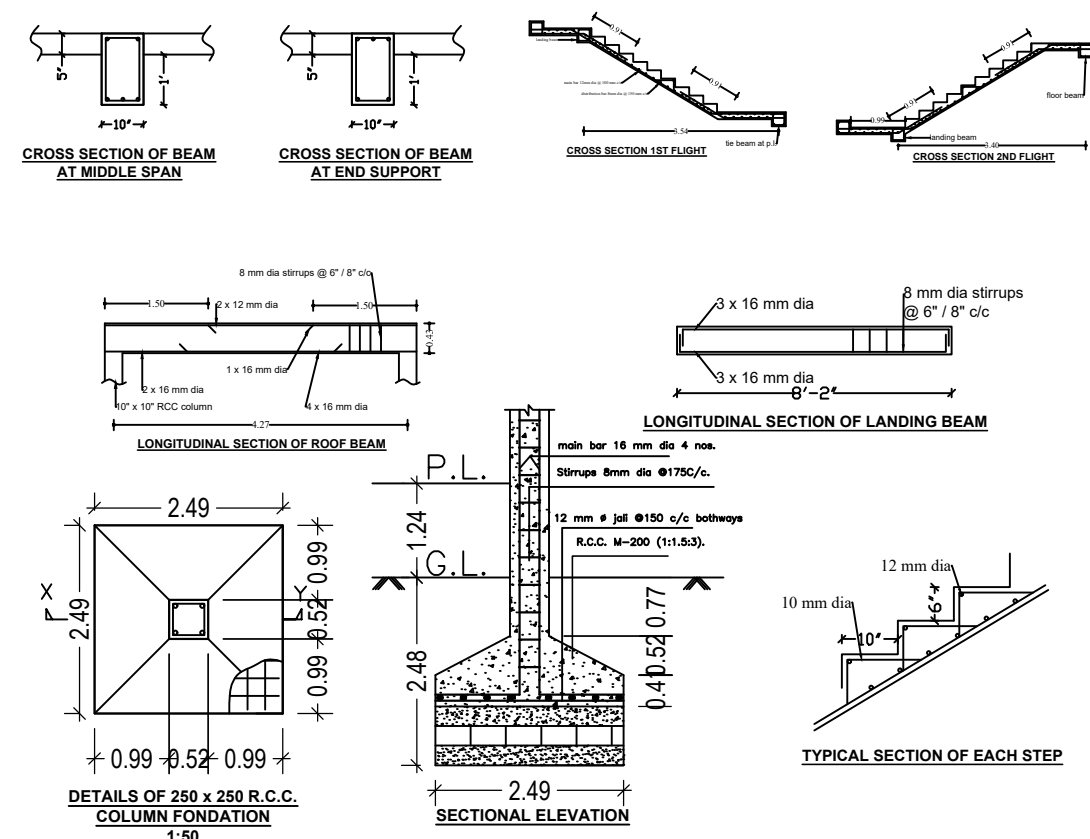

DETAIL OF SEPTIC TANK AND SOAK PIT

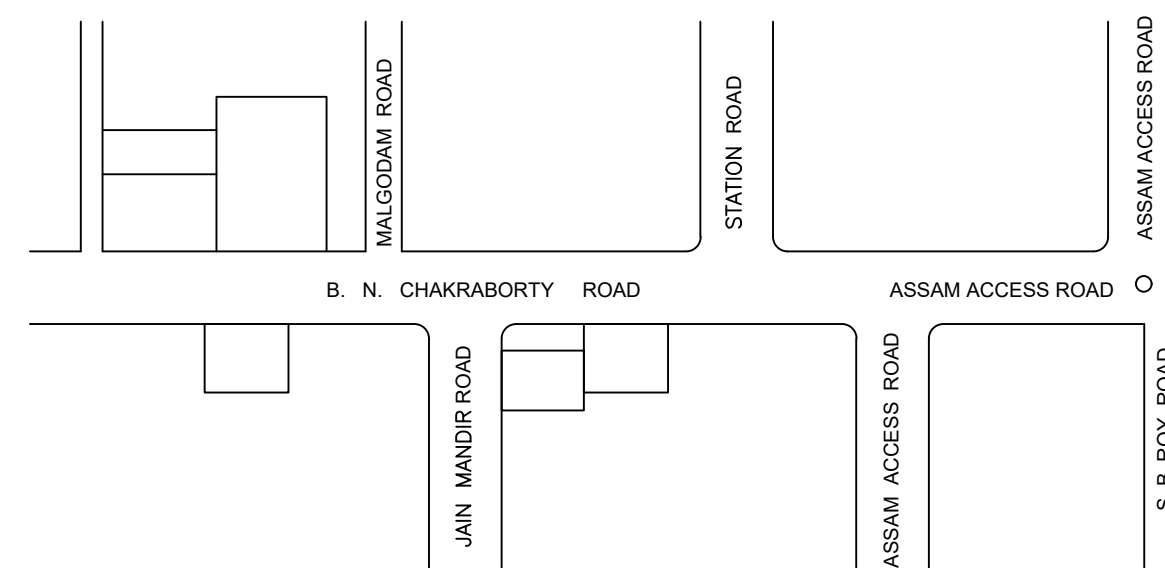

KEY PLAN NTS

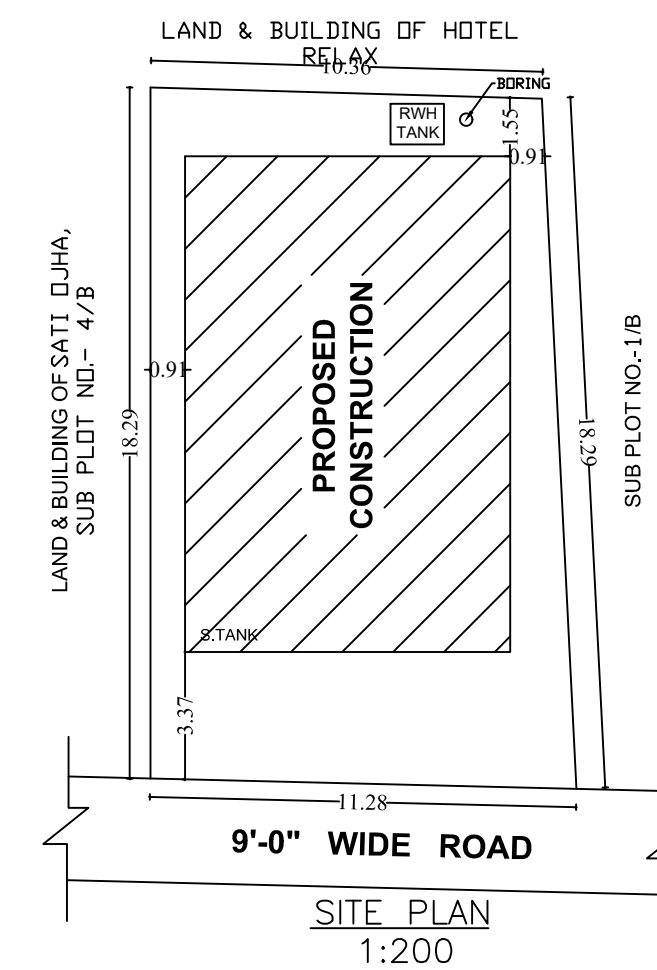

9'-0" WIDE ROAD
SITE PLAN 1:200

LTP NAME AND SIGNATURE	STRUCTURAL ENG'S NAME AND SIGNATURE	BUILDER NAME AND SIGNATURE	DIGITAL SIGNATURE
YAMUNA PRASAD LACHHIRAMKA DGMC/ENG/0013/2017			