

Buildingwise Floor FAR Details

Floor Name	Building Name		Total	
	Proposed Built Up Area (Sq.mt.)	Proposed FAR Area (Sq.mt.)	Total Proposed Built Up Area (Sq.mt.)	Total FAR Area (Sq.mt.)
Ground Floor	80.32	80.32	80.32	80.32
First Floor	80.32	80.32	80.32	80.32
Terrace Floor	0.00	0.00	0.00	0.00
Total :	160.64	160.64	160.64	160.64

FAR & Tenement Details (Table 4c-1)

Building	No. of Same Bldg	Total Built Up Area (Sq.mt.)	Proposed FAR Area (Sq.mt.)	Total FAR Area (Sq.mt.)	Total Consumed Additional FAR Area (Sq.mt.)	Tnmt (No.)
RESI (PRABHA KUMARI)	1	160.64	160.64	160.64	160.64	01
Grand Total :	1	160.64	160.64	160.64	160.64	01

Building USE/SUBUSE Details

Building Name	Building Use	Building SubUse	Building Structure
RESI (PRABHA KUMARI)	Residential	Bungalow/ Dwelling / Non Apartment	Non-Highrise

COLOR INDEX

PLOT BOUNDARY	Black
ABUTTING ROAD	Green
PROPOSED CONSTRUCTION	Red
COMMON PLOT	Yellow
ROAD WIDENING AREA	Blue
EXISTING (To be retained)	Blue
EXISTING (To be demolished)	Yellow

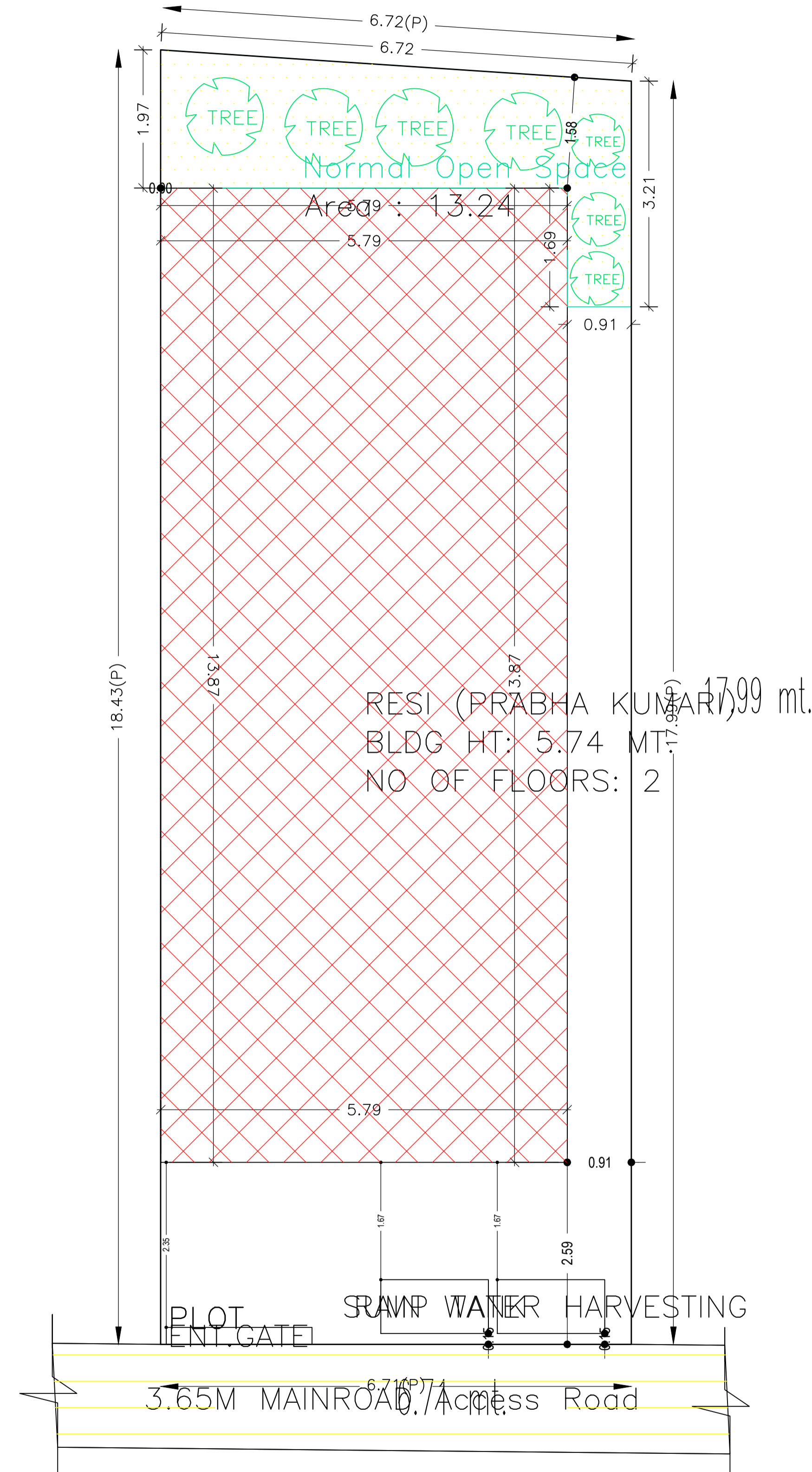

SITE PLAN

SITE PLAN

AREA STATEMENT	VERSION NO.:	SQ.MT.
DEOGHAR MUNICIPAL CORPORATION	1.0.49	122.00
PROJECT DETAIL:	VERSION DATE: 22/06/2020	
Region: JHARKHAND URBAN LOCAL BODIES	Plot Use: Residential	
District: DEOGHAR	Plot SubUse: Semidetached	
Authority: DEOGHAR MUNICIPAL CORPORATION	PlotNearbyReligiousStructure: NA	
Inward No: DGMC/BP/0066/W02/2020	Plot/SubPlot No: 697	
Application Type: General Proposal	North: Plot No. - SUB PLOT NO.104/A,105,106(PART)	
Project Type: Building Permission	South: Plot No. - HOUSE OF GAYATRI DEVI	
Nature of Development: New	East: Survey No. - MOUZA RAMCHANDRAPUR	
Location of Development Area: Old Area	West: Road Width - 3.65 M WIDE ROAD	
AREA DETAILS:		
AREA OF PLOT (Minimum)	(A)	122.00
NET AREA OF PLOT(Gross Plot Area - Deduction from Gross Plot area)	(A-Deductions)	122.00
Deduction for Balance Plot Area(from Gross Plot Area)		
Common Plot		13.24
Total		13.24
BALANCE AREA OF PLOT(Net Plot Area - Recreational/Amenity space)	(A-Deductions)	108.76
PLOT AREA FOR COVERAGE(Net Plot Area)	(A-Deductions)	122.00
Plot Area for FAR (Net Plot Area + RoadWidening Area)	(A-Deductions)	122.00
COVERAGE CHECK		
Permissible Coverage area (70.00 %)		85.40
Proposed Coverage Area (65.84 %)		80.32
Total Prop. Coverage Area (65.84 %)		80.32
Balance coverage area (4.16 %)		5.08
FAR CHECK		
Perm. FAR Area (1.50)		183.00
Total Perm. FAR area		183.00
Residential FAR		160.65
Proposed FAR Area		160.65
Total Proposed FAR Area		160.65
Consumed FAR (Factor)		1.32
Balance FAR Area		22.35
BUILT UP AREA CHECK		
Total Proposed BuiltUp Area		160.64
ARCHITECT (Regd)	RAMESH CHANDRA	
ENGINEER (Regd)		
SUPERVISOR (Regd)		
OWNER (Regd)	SMT.PRABHA KUMARI	
DEVELOPMENT AUTHORITY	LOCAL BODY	

Proposal File No	DGMC/BP/0066/W02/2020
Owner Name	SMT.PRABHA KUMARI
Khata No	50/9,15/34
Plot No	697
Village Name	Deoghar
Use	Residential
SubUse	Semidetached

LTP NAME AND SIGNATURE	STRUCTURAL ENG'S NAME AND SIGNATURE	BUILDER NAME AND SIGNATURE	DIGITAL SIGNATURE
RAMESH CHANDRA DGMC/ENG/0021/2017			



Proposal Basic Information	
Proposal File No.	DGMC/BP/0066/W02/2020
Owner Name	SMT.PRABHA KUMARI
Khata No	50/9,15/34
Plot No	697
Village Name	Deoghar
Use	Residential
SubUse	Semidetached

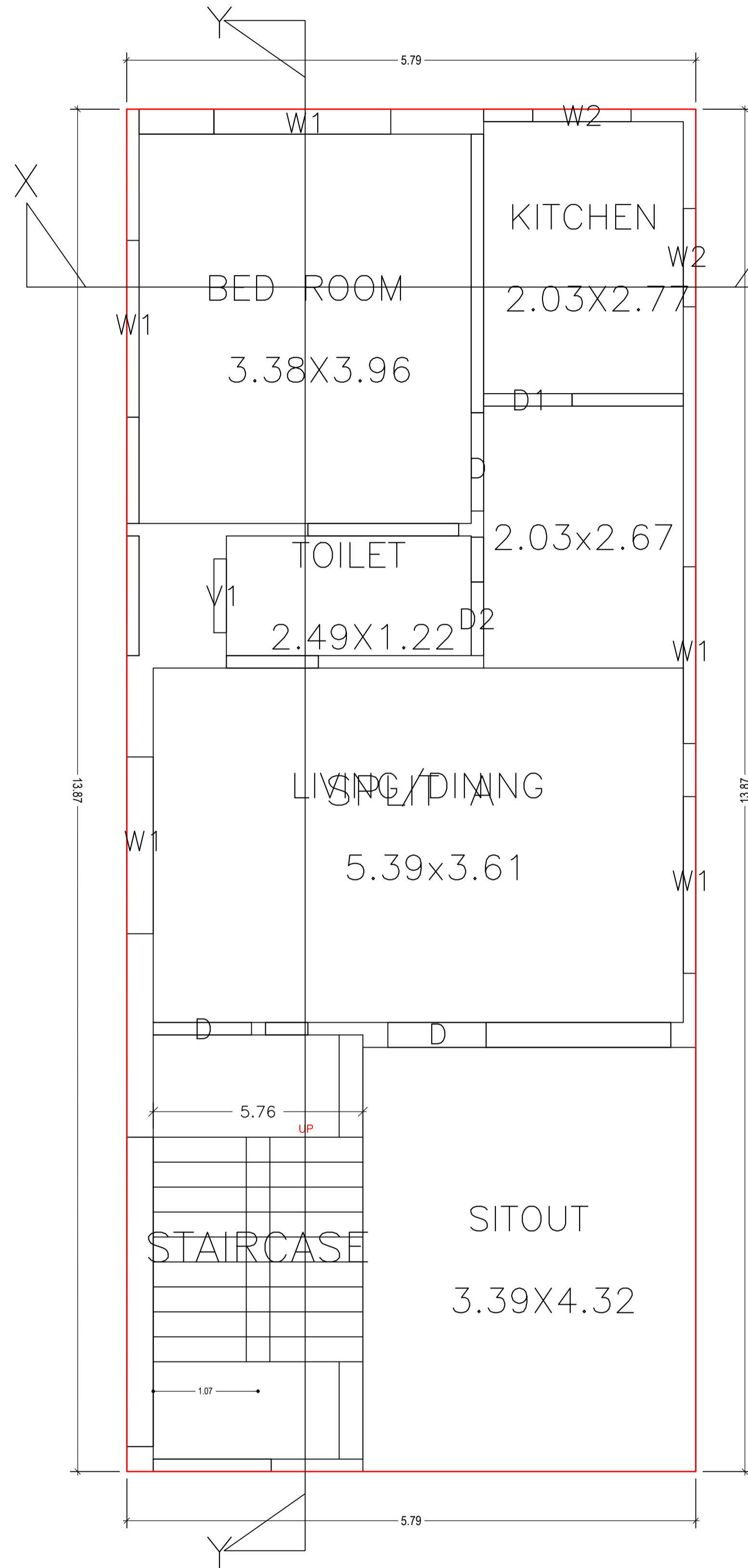

GROUND FLOOR PLAN
(Proposed)
(SCALE 1:100)

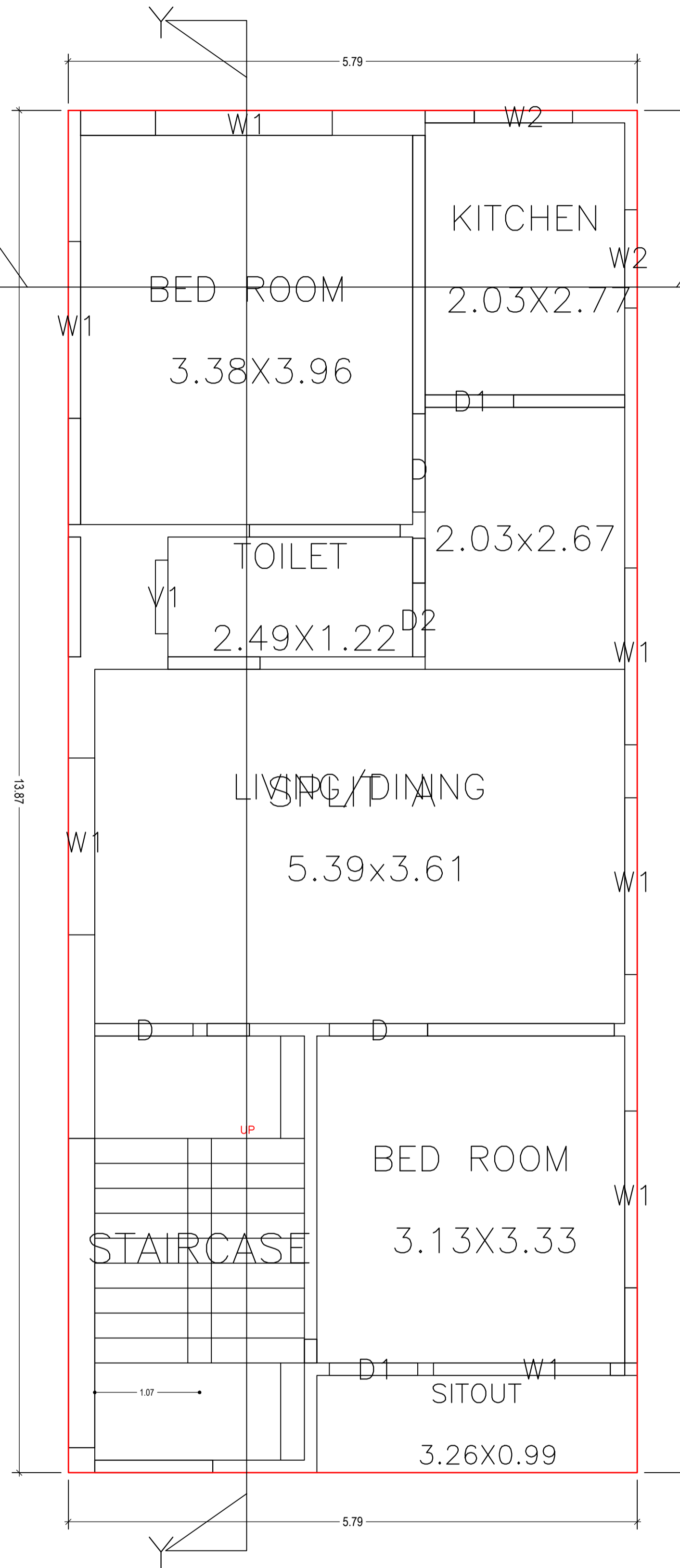

FIRST FLOOR PLAN
(Proposed)
(SCALE 1:100)

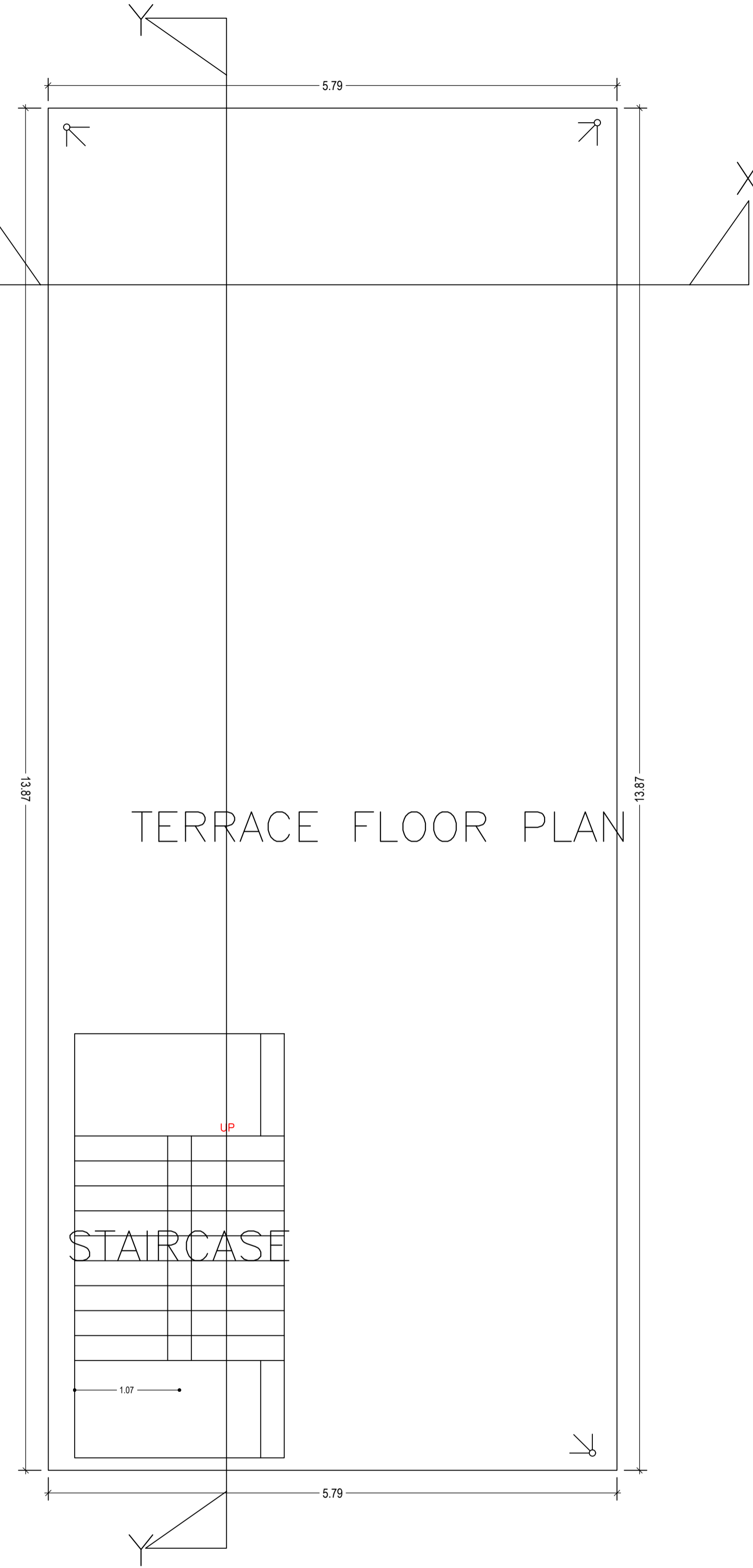

TERRACE FLOOR PLAN
(SCALE 1:100)

LTP NAME AND SIGNATURE	STRUCTURAL ENG'S NAME AND SIGNATURE	BUILDER NAME AND SIGNATURE	DIGITAL SIGNATURE
RAMESH CHANDRA DGMC/ENG/0021/2017			



Proposal Basis Information	
Proposal File No.	DGMC/BP/0066/W02/2020
Owner Name	SMT.PRABHA KUMARI
Khata No	50/9,15/34
Plot No	697
Village Name	Deoghar
Use	Residential
SubUse	Semidetached

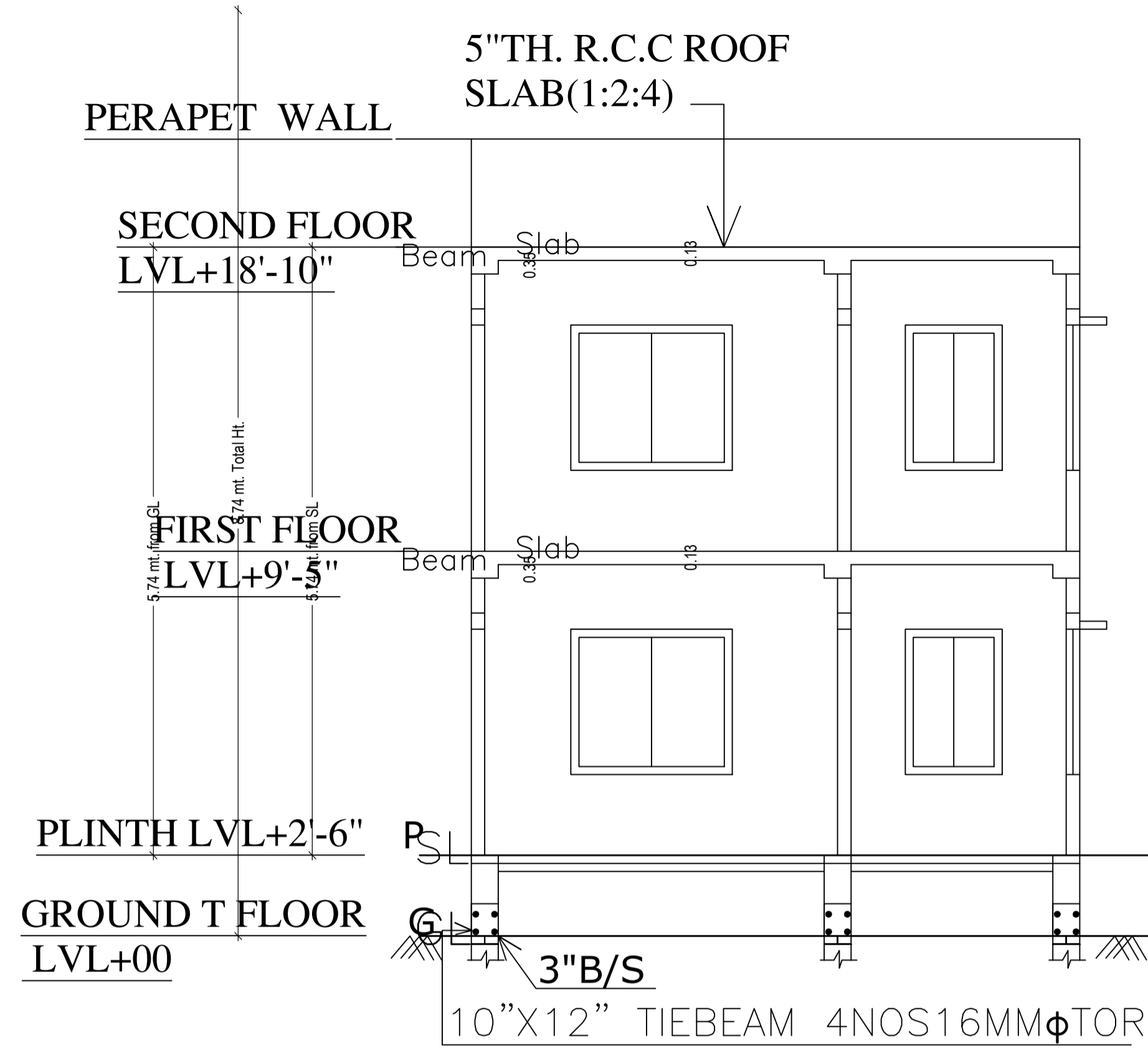

SECTION AT X-X

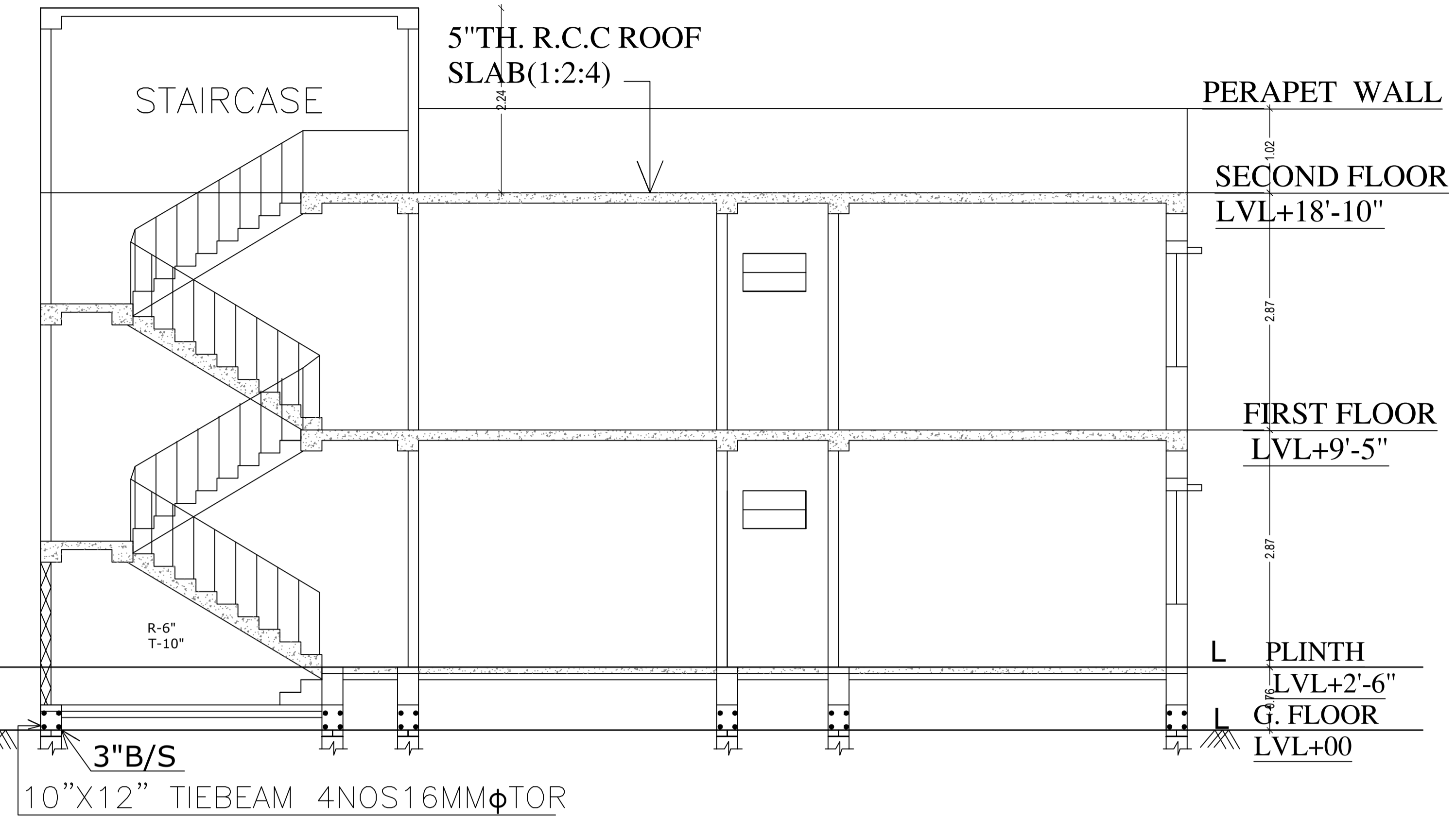

SECTION AT Y-Y

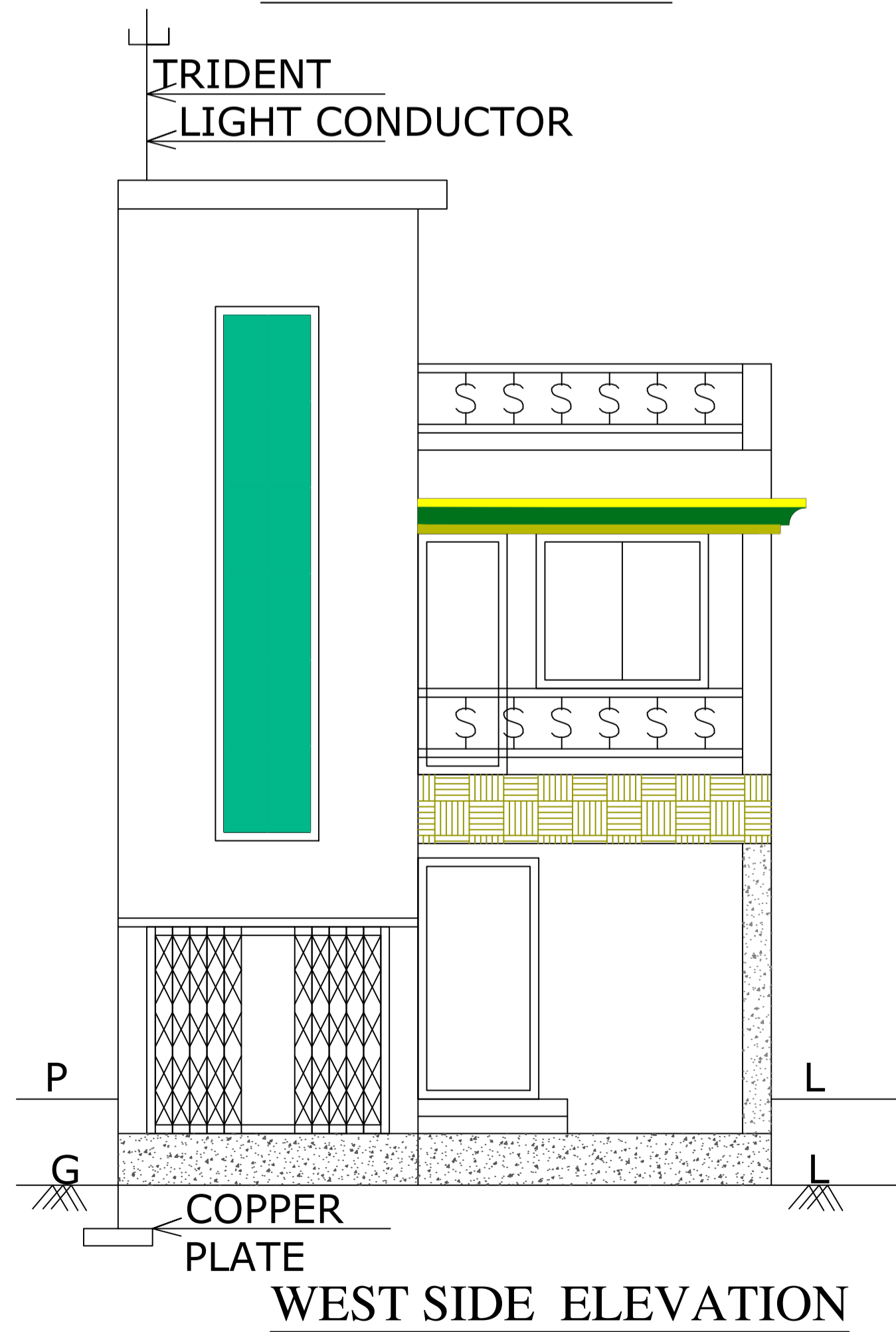

WEST SIDE ELEVATION

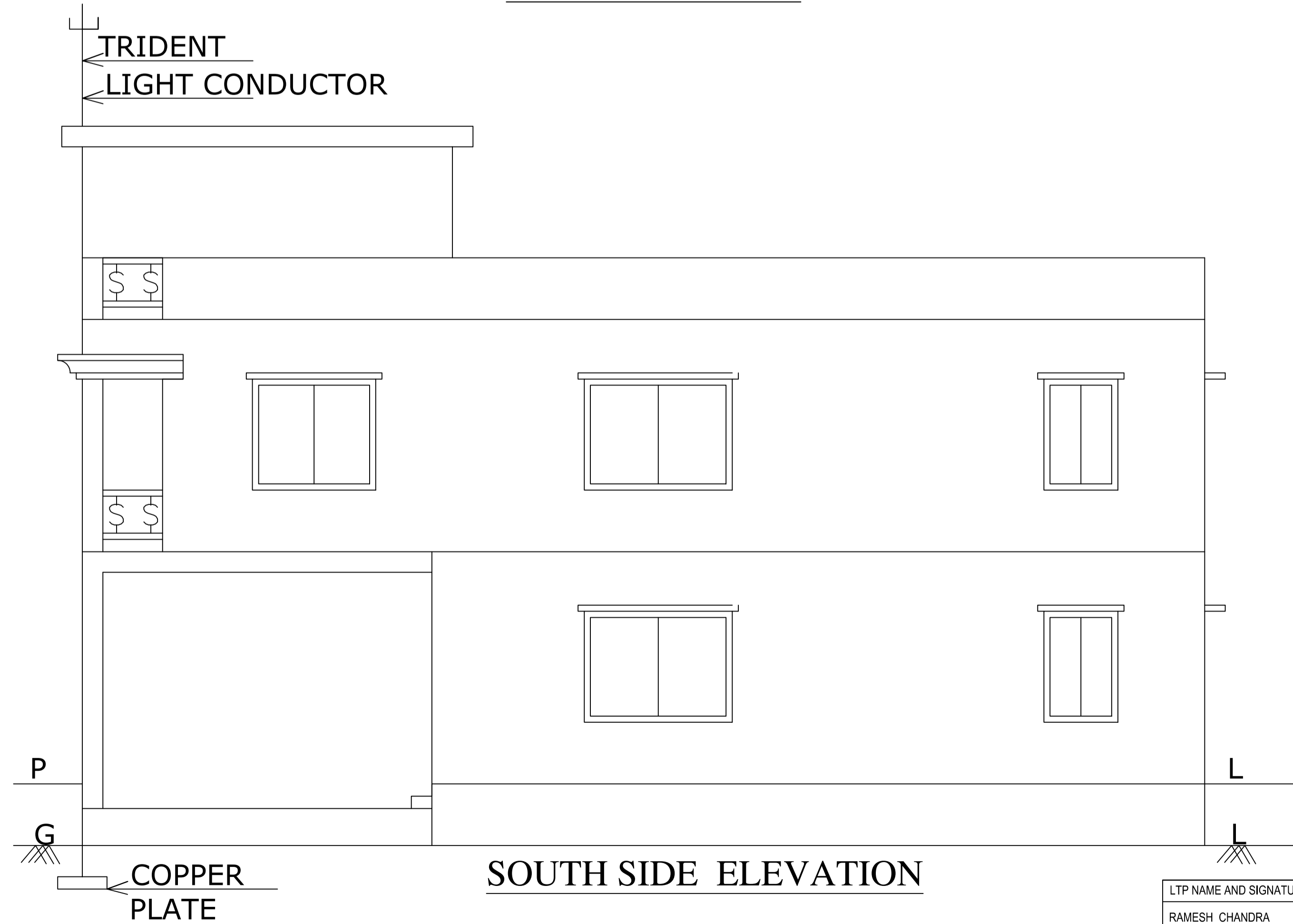

SOUTH SIDE ELEVATION

LTP NAME AND SIGNATURE	STRUCTURAL ENG'S NAME AND SIGNATURE	BUILDER NAME AND SIGNATURE	DIGITAL SIGNATURE
RAMESH CHANDRA DGMC/ENG/0021/2017			

Proposal Basic Information	
Proposal File No	DGMC/BP/0066/W02/2020
Owner Name	SMT.PRABHA KUMARI
Khata No	50/9,15/34
Plot No	697
Village Name	Deoghar
Use	Residential
SubUse	Semidetached

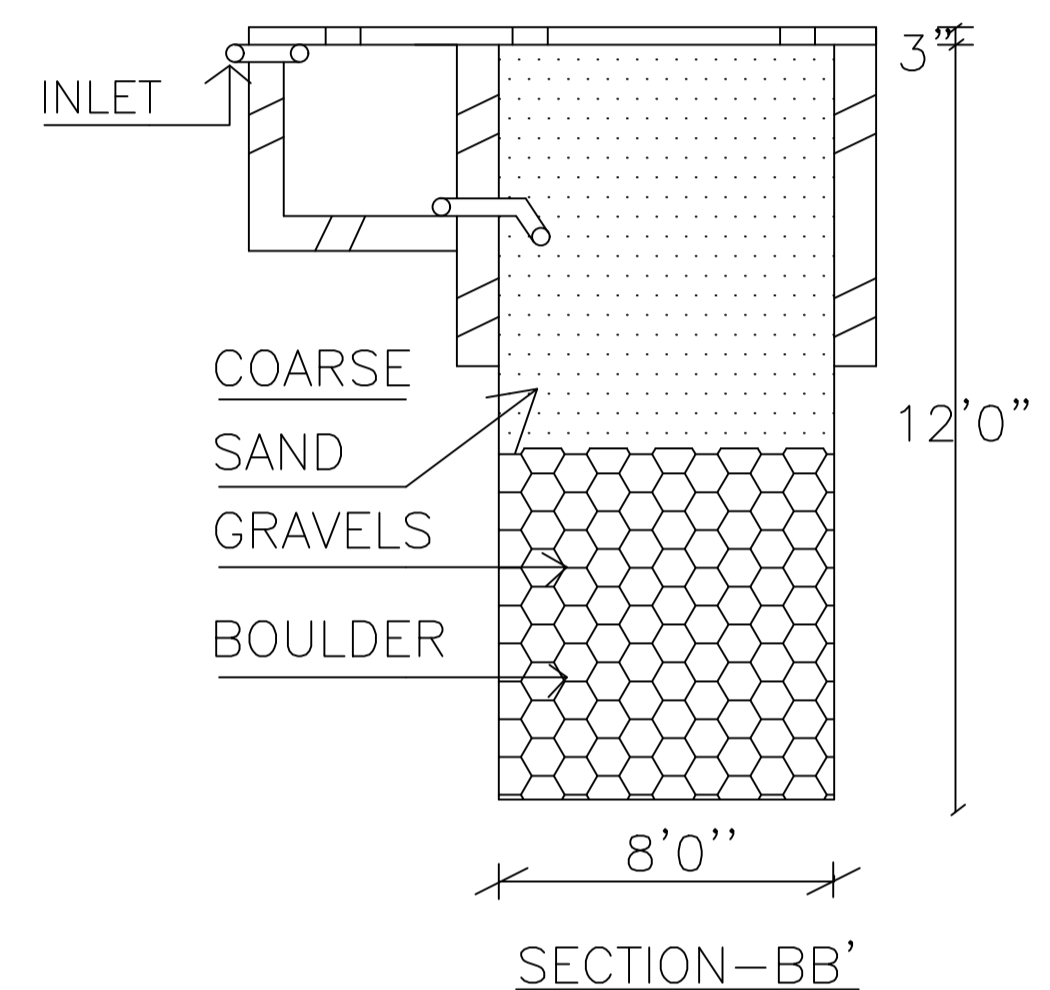
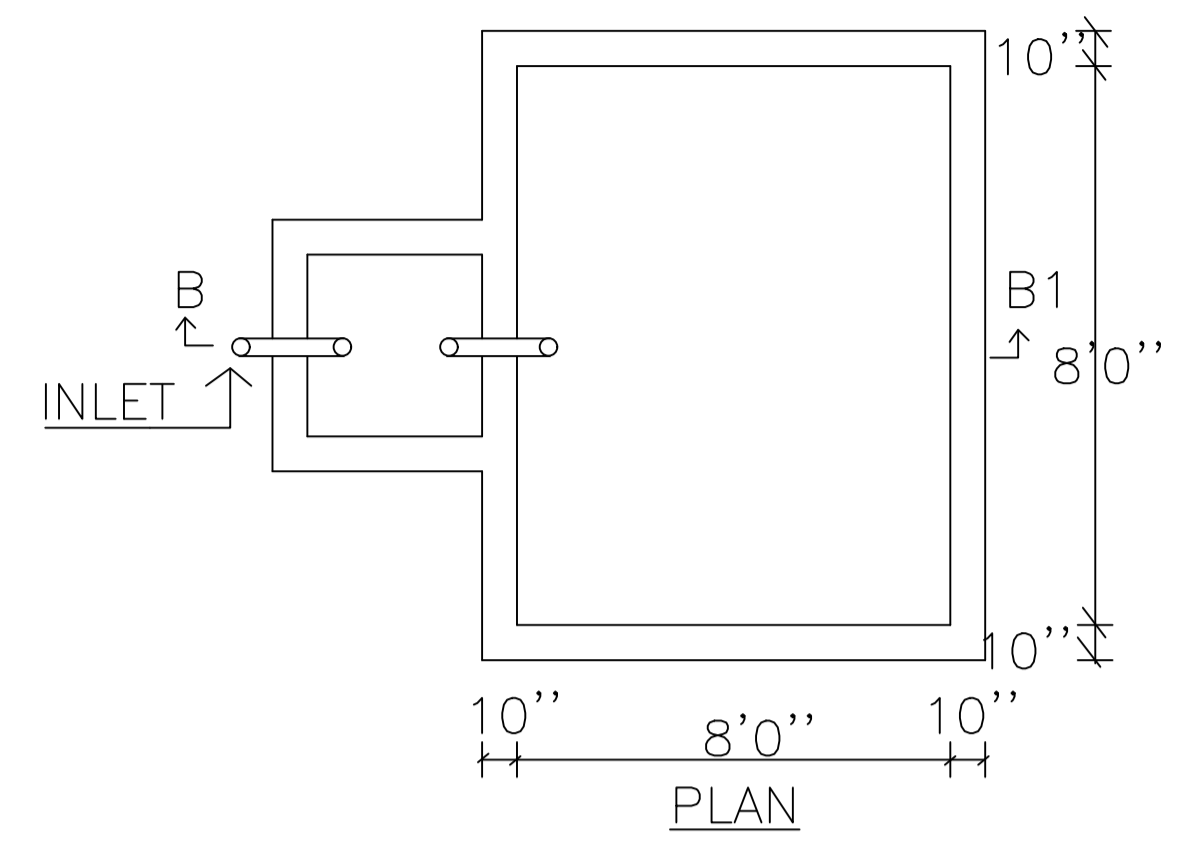
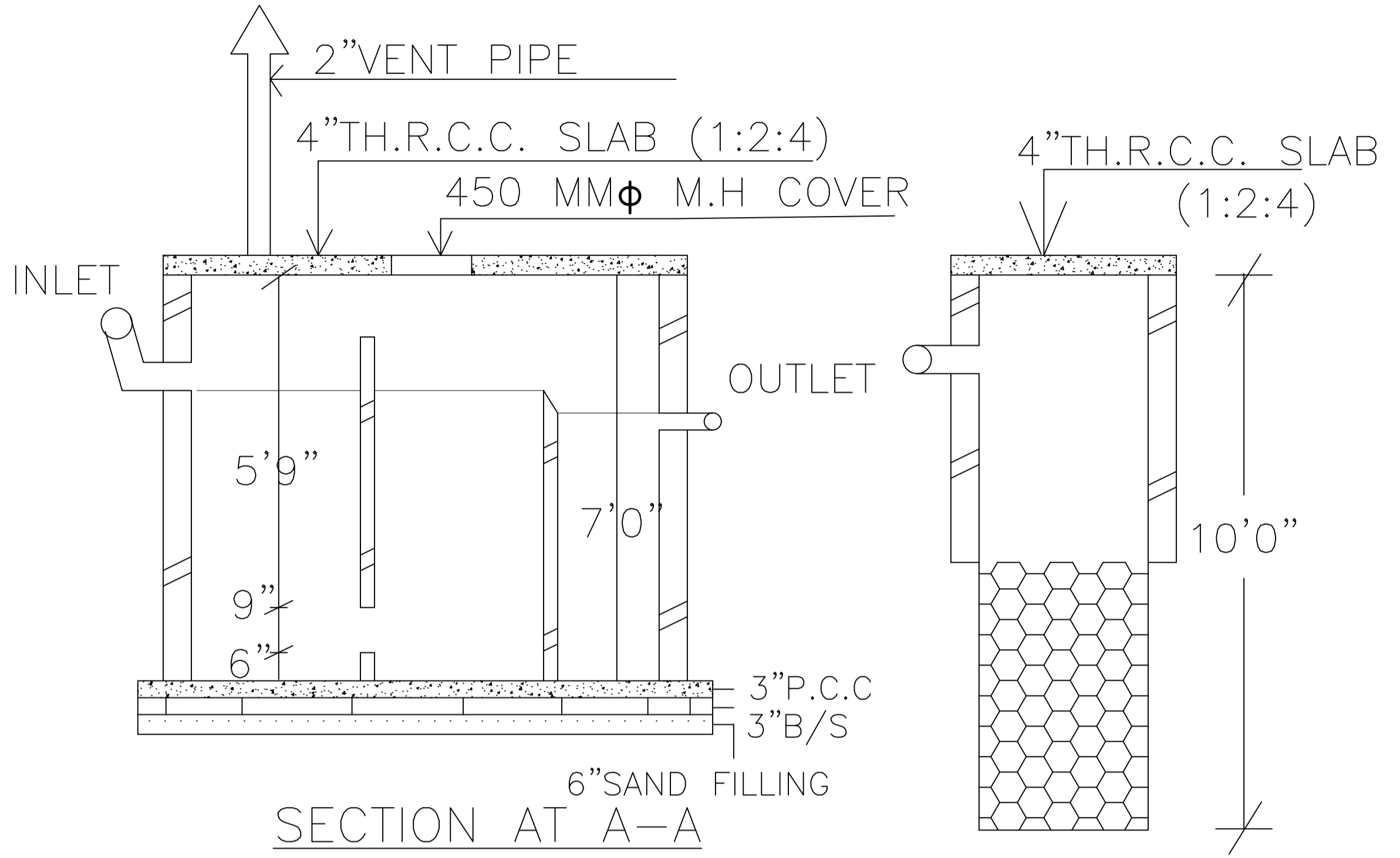

RAIN WATER HARVESTING SCHEME

BOUNDARY LINE OF RAM CHANDRAPUR

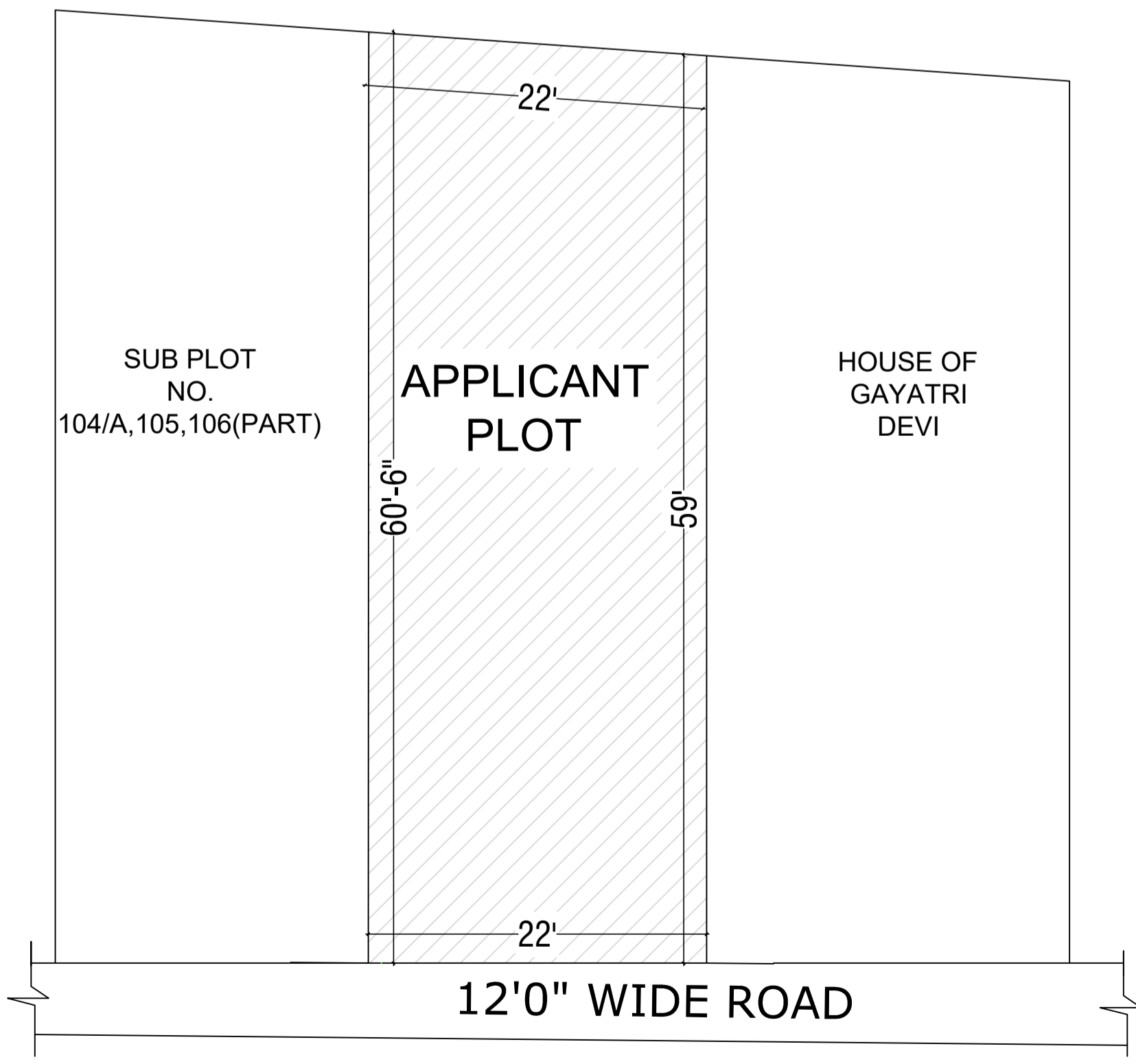

KEY PLAN

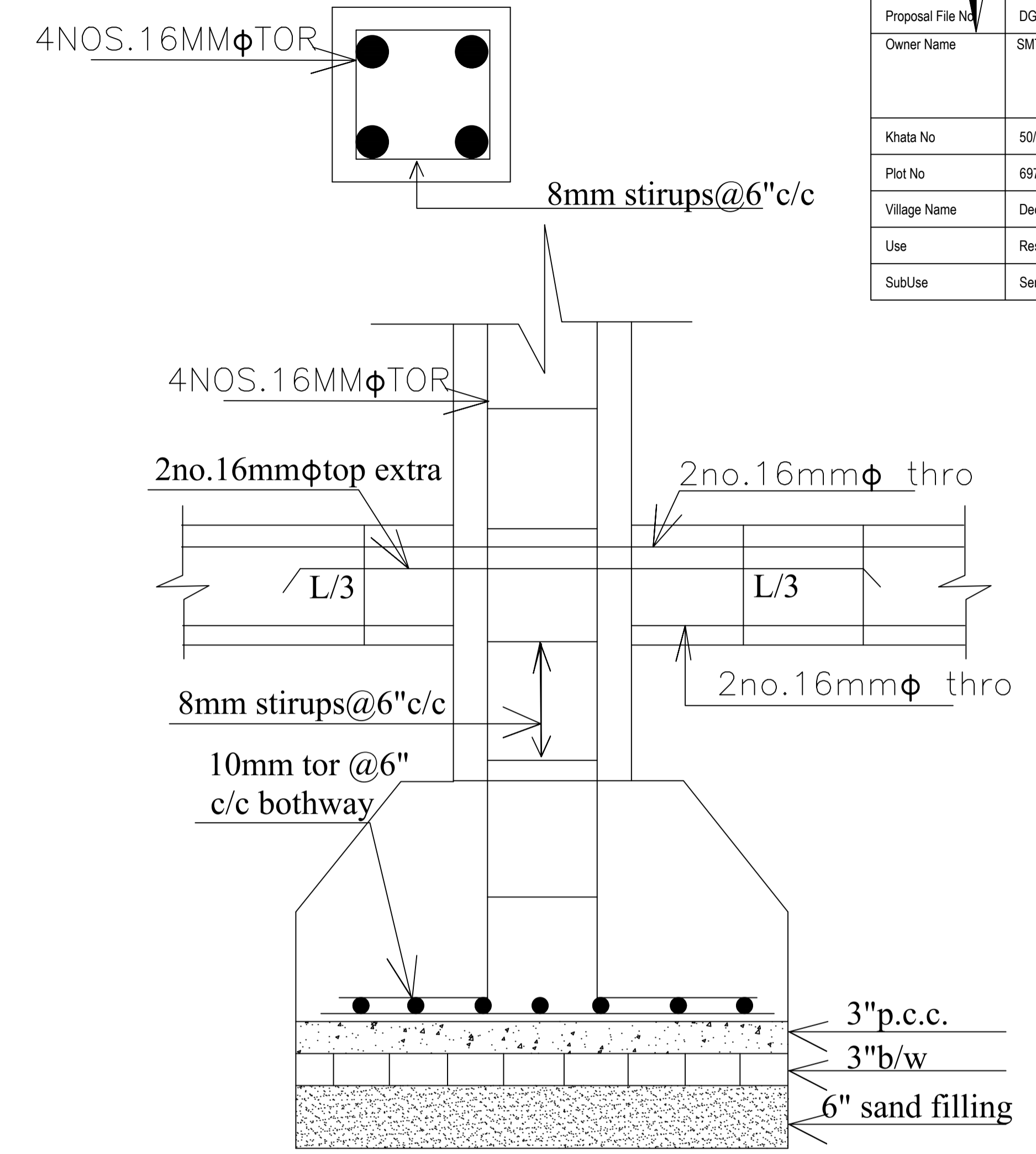

COLUMN (10''X10'')

Building :RESI (PRABHA KUMARI)

Floor Name	Total Built Up Area (Sq.mt.)	Proposed FAR Area (Sq.mt.) Resi	Total FAR Area (Sq.mt.)	Total Consumed Additional FAR Area (Sq.mt.)	Tnmt (No.)
Ground Floor	80.32	80.32	80.32	80.32	01
First Floor	80.32	80.32	80.32	80.32	00
Terrace Floor	0.00	0.00	0.00	0.00	00
Total :	160.64	160.64	160.64	160.64	01
Total Number of Same Buildings :	1				
Total :	160.64	160.64	160.64	160.64	01

UnitBUA Table for Building :RESI (PRABHA KUMARI)

FLOOR	Name	UnitBUA Type	UnitBUA Area	Carpet Area	No. of Rooms	No. of Tenement
GROUND FLOOR PLAN	SPLIT A	FLAT	149.09	146.46	5	1
FIRST FLOOR PLAN	SPLIT A	FLAT	0.00	0.00	6	0
Total:	-	-	149.09	146.46	11	1

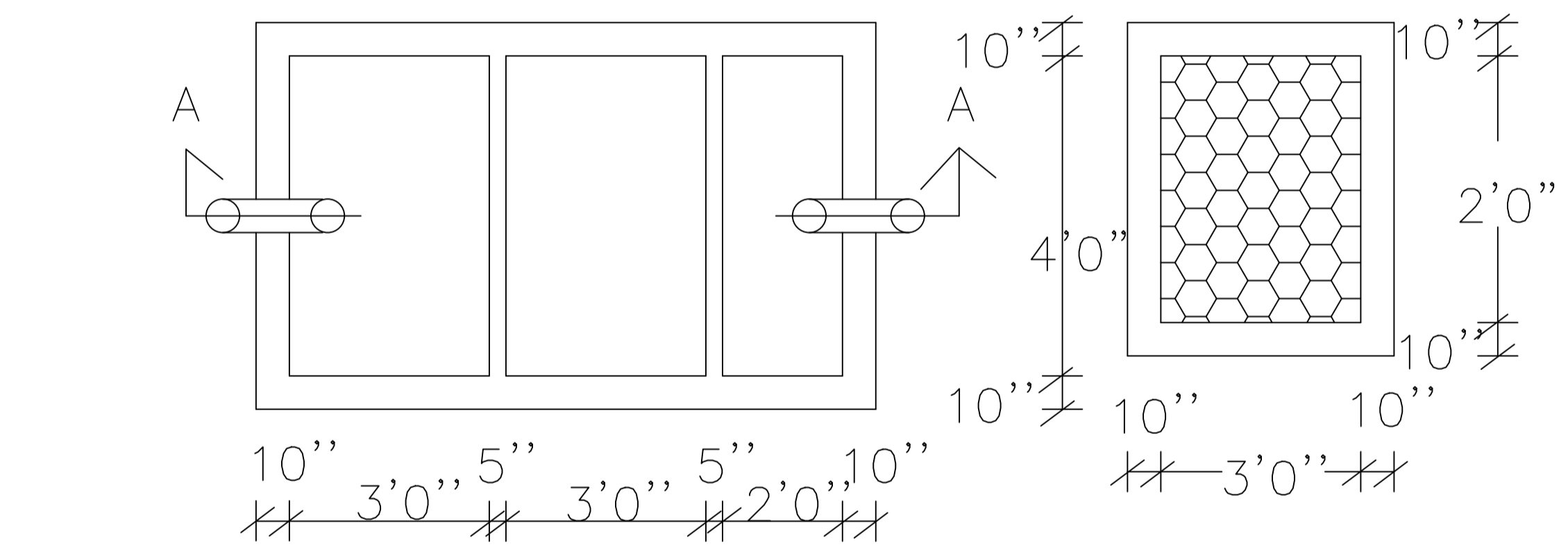

SEPTIC TANK AND SOAK - PIT

SCHEDULE OF DOOR:

BUILDING NAME	NAME	LENGTH	HEIGHT	NOS
RESI (PRABHA KUMARI)	D2	0.75	2.10	02
RESI (PRABHA KUMARI)	D1	0.90	2.10	03
RESI (PRABHA KUMARI)	D	1.00	2.10	06

SCHEDULE OF WINDOW/VENTILATION:

BUILDING NAME	NAME	LENGTH	HEIGHT	NOS
RESI (PRABHA KUMARI)	V1	0.75	0.90	02
RESI (PRABHA KUMARI)	W2	1.00	1.20	04
RESI (PRABHA KUMARI)	W1	1.80	1.20	12

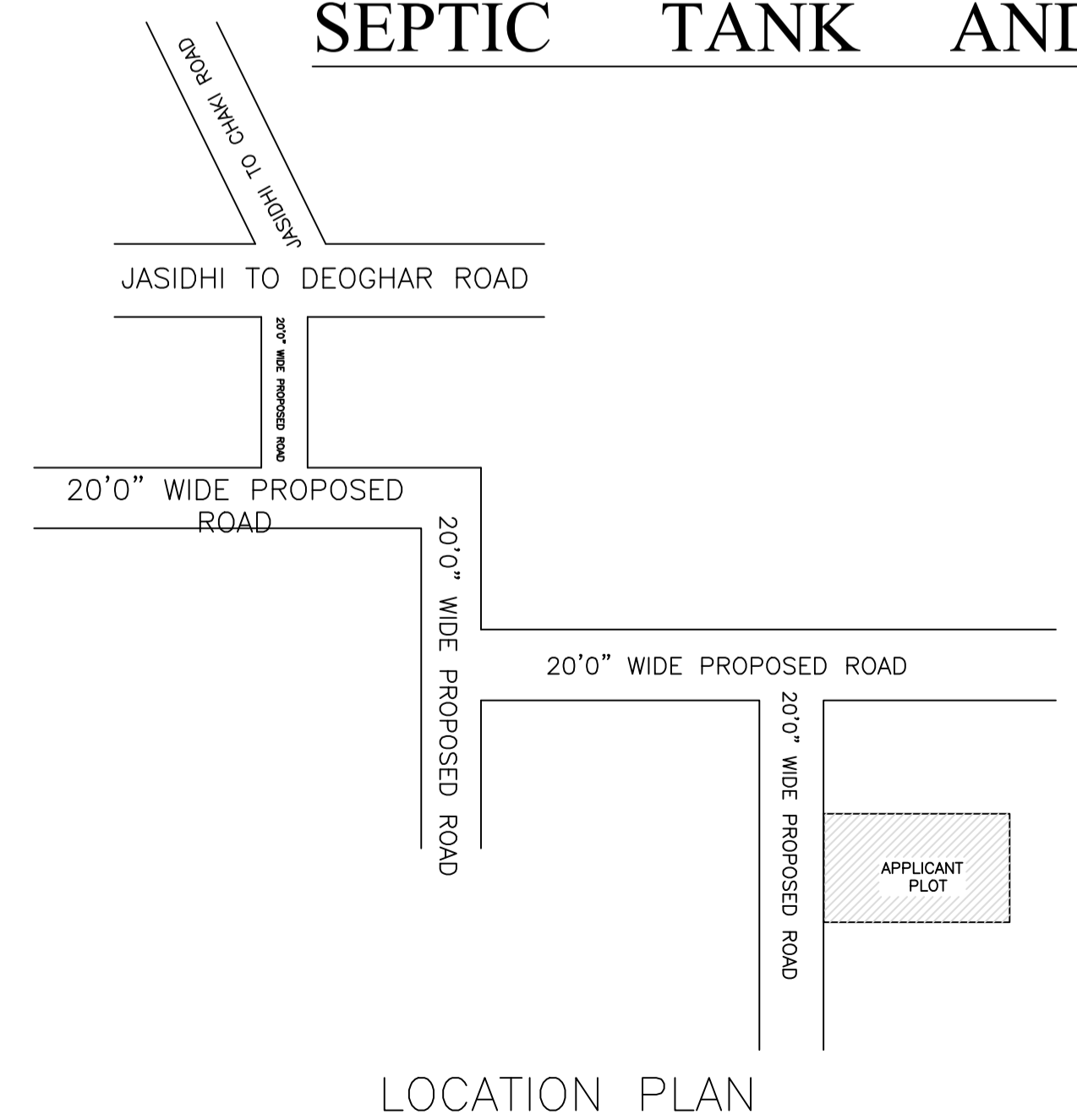

LOCATION PLAN

LTP NAME AND SIGNATURE	STRUCTURAL ENG'S NAME AND SIGNATURE	BUILDER NAME AND SIGNATURE	DIGITAL SIGNATURE
RAMESH CHANDRA DGMC/ENG/0021/2017			