

Proposal Basic Information

Proposal File No.	DGMC/BP/0024/W32/2020
Owner Name	SMT BINDU KUMARI
Khata No	54/3217/2/1
Plot No	776
Village Name	Deoghar
Use	Residential
SubUse	Bungalow/ Dwelling / Non Apartment

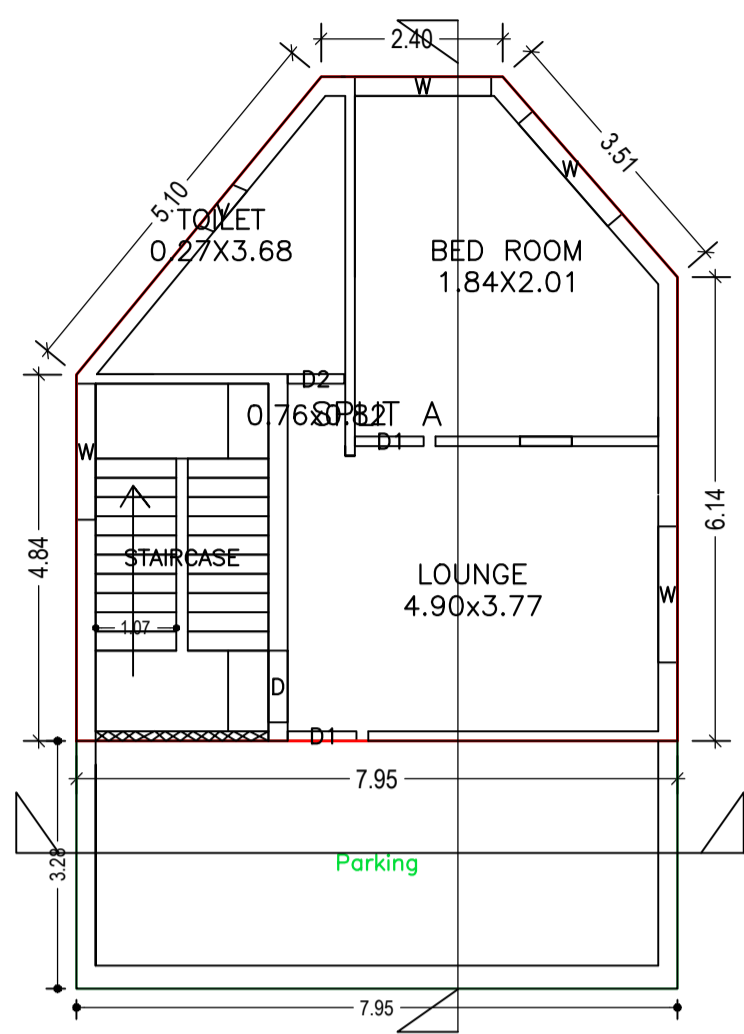

GROUND FLOOR PLAN
(Proposed)
(SCALE 1:100)

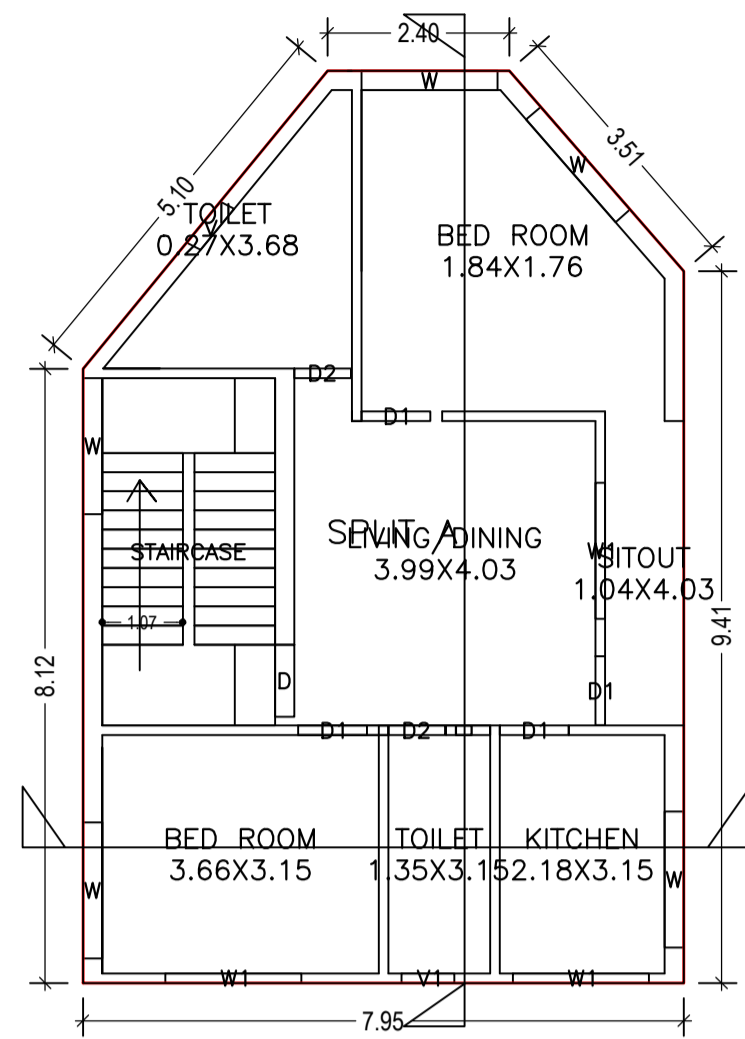

FIRST FLOOR PLAN
(Proposed)
(SCALE 1:100)

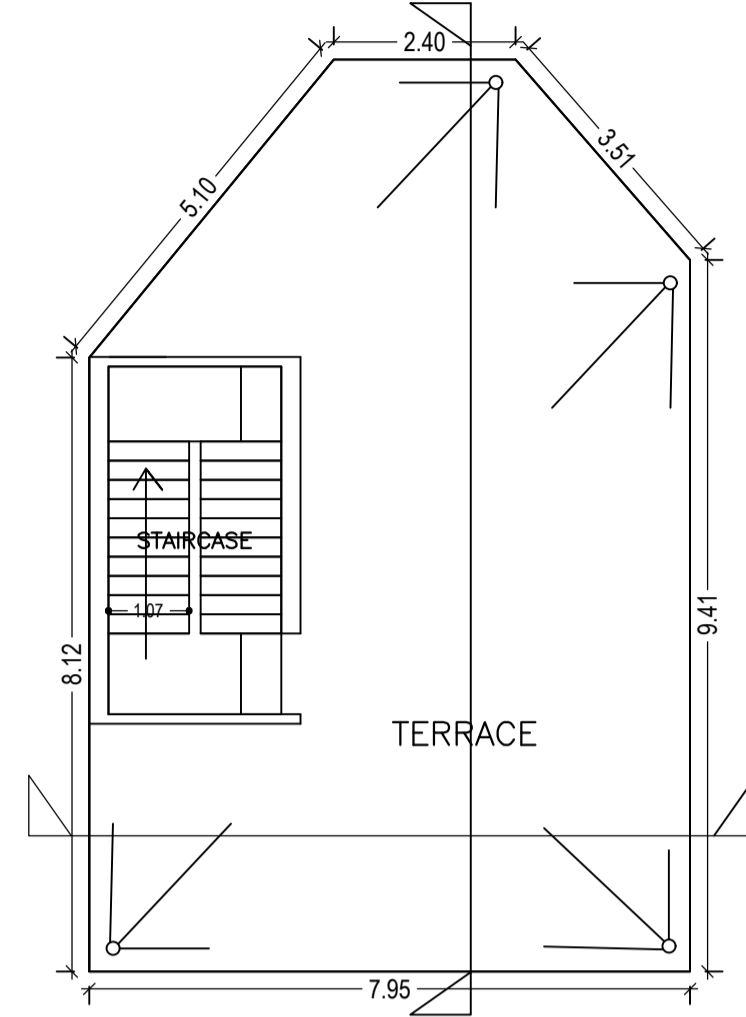

TERRACE FLOOR PLAN
(SCALE 1:100)

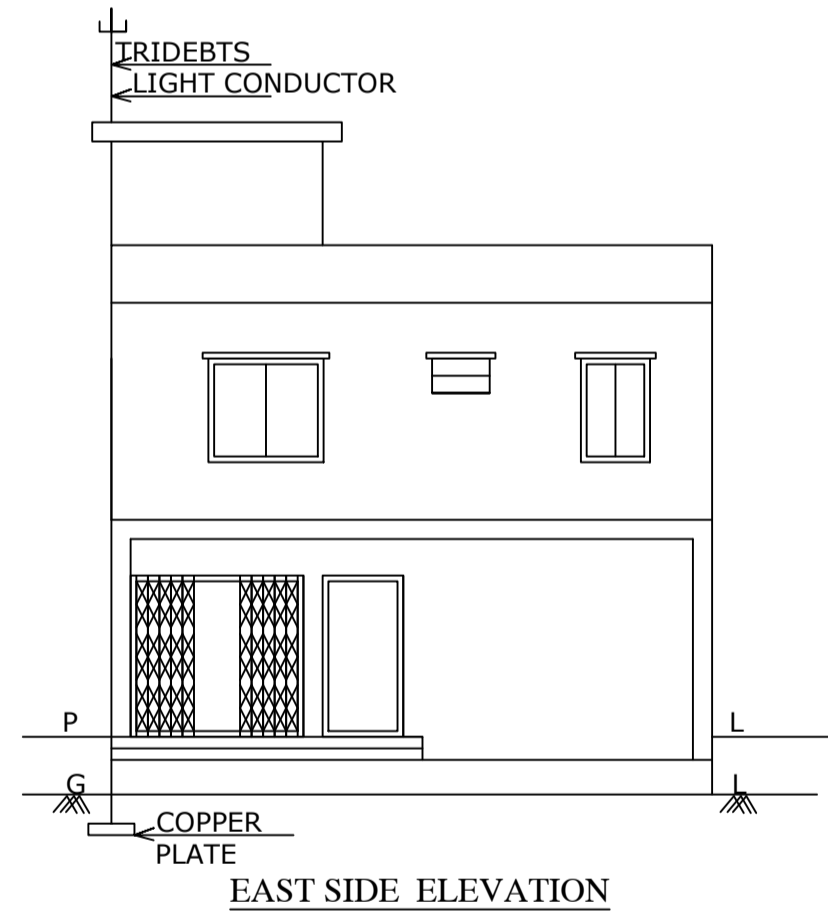

EAST SIDE ELEVATION

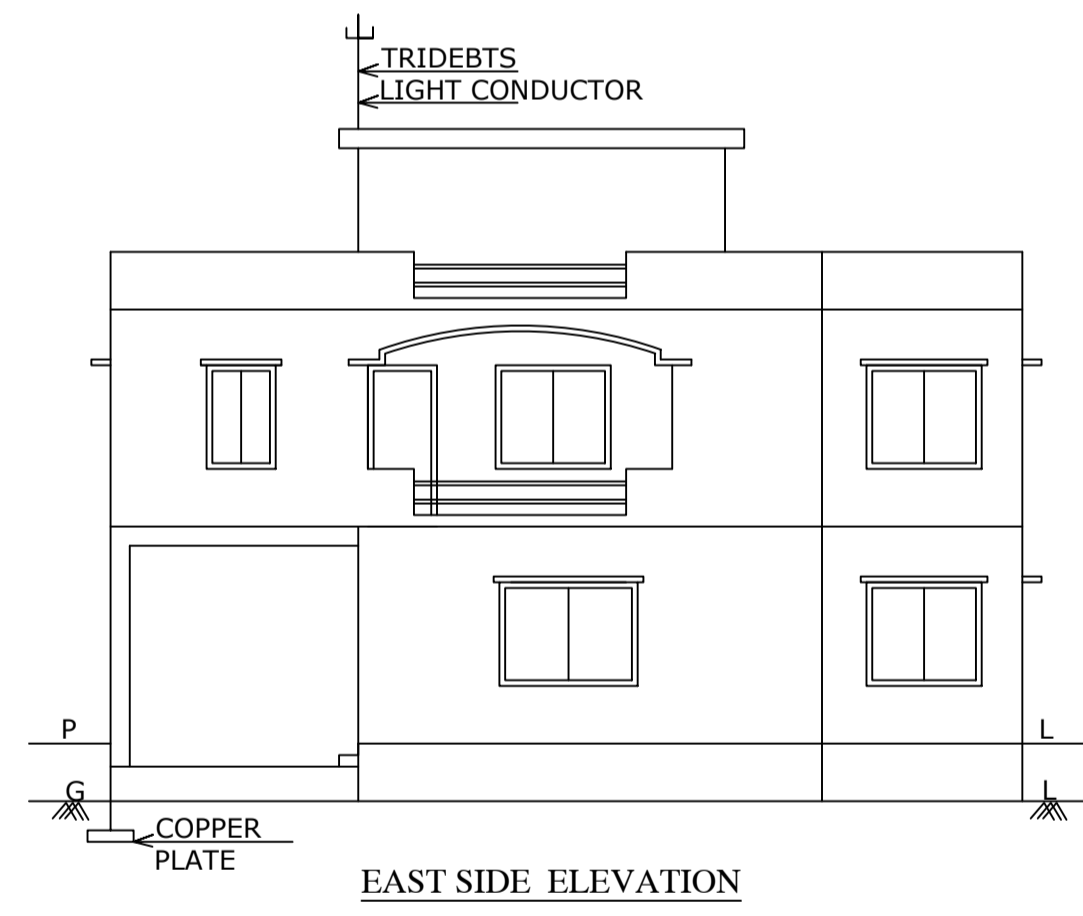

EAST SIDE ELEVATION

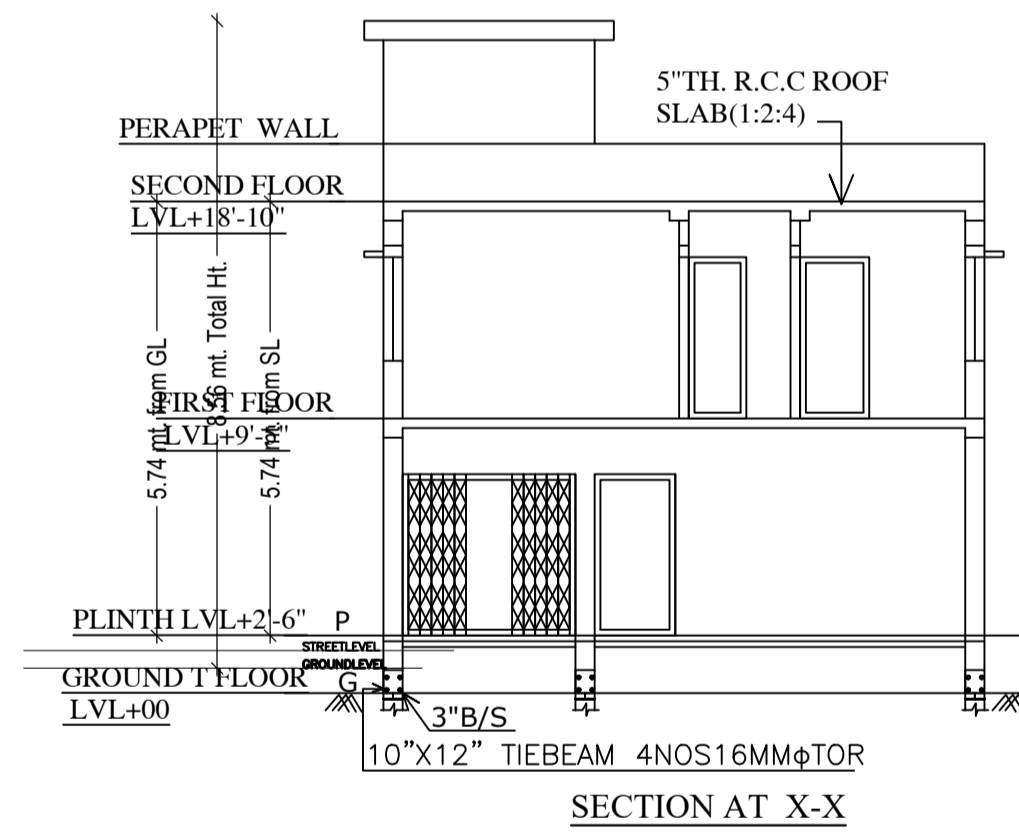

SECTION AT X-X

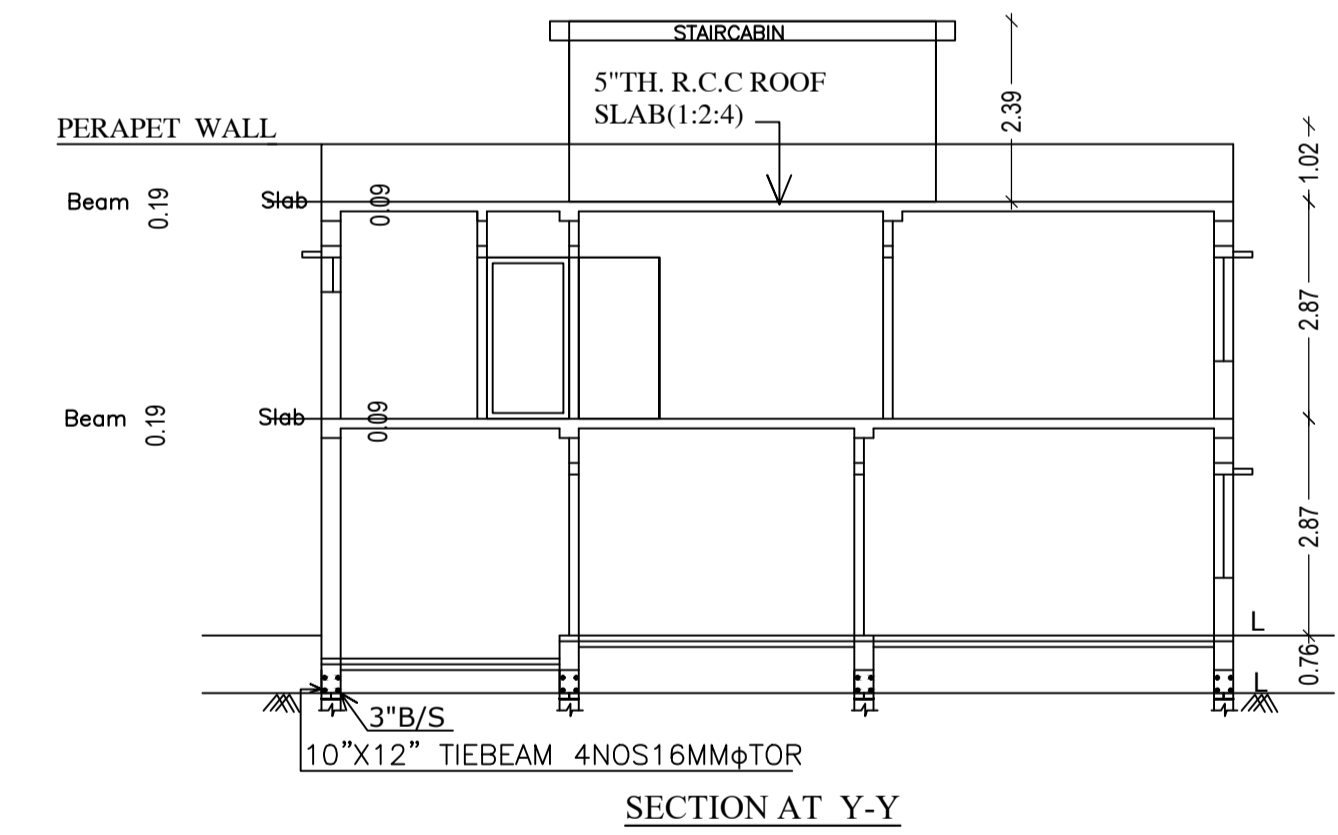

SECTION AT Y-Y

LTP NAME AND SIGNATURE	STRUCTURAL ENG'S NAME AND SIGNATURE	BUILDER NAME AND SIGNATURE	DIGITAL SIGNATURE
ALOK KUMAR SINGH DGMC/ENG/0007/2017			

Proposal Basic Information	
Proposal File No.	DGMC/BP/0024/W32/2020
Owner Name	SMT BINDU KUMARI
Khata No	54/3217/2/1
Plot No	776
Village Name	Deoghar
Use	Residential
SubUse	Bungalow/ Dwelling / Non Apartment

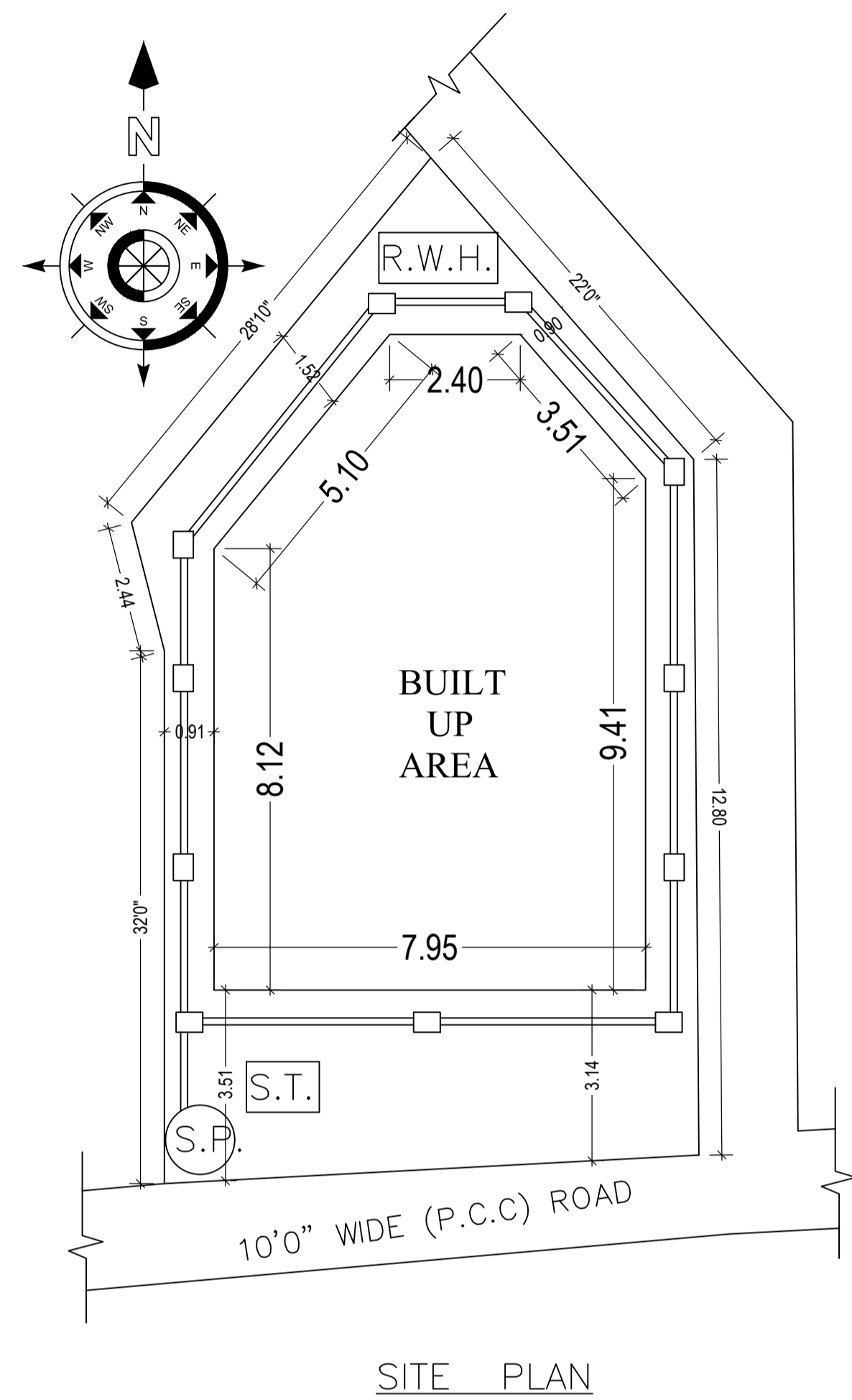

SITE PLAN

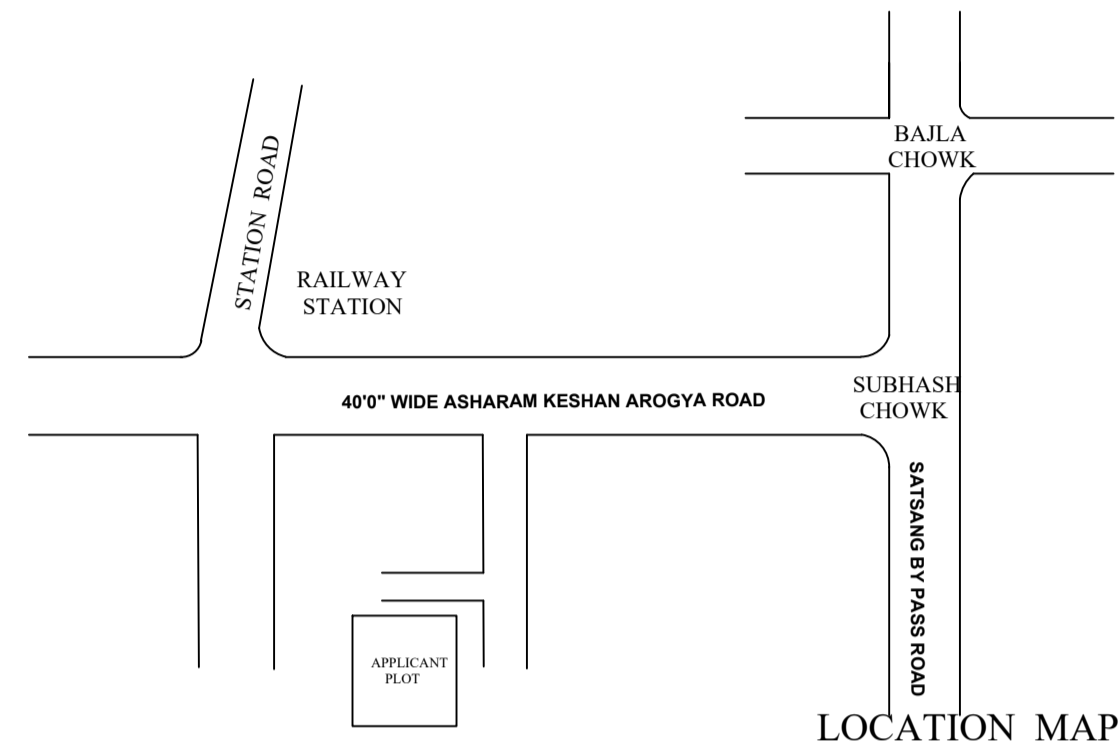

LOCATION MAP

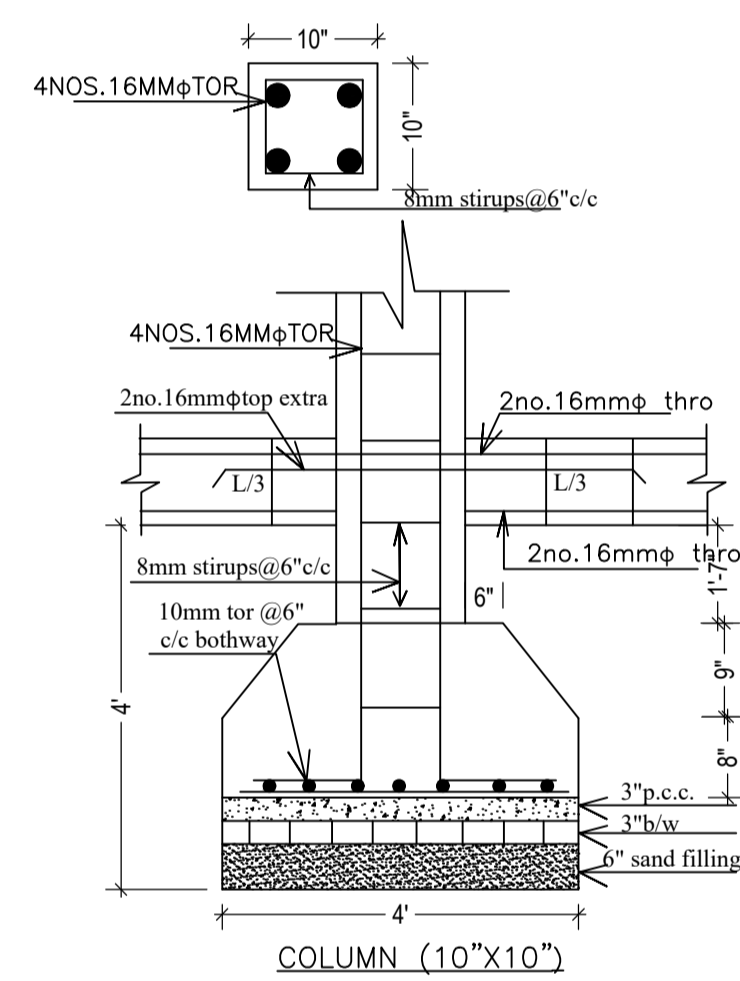

COLUMN (10"X10")

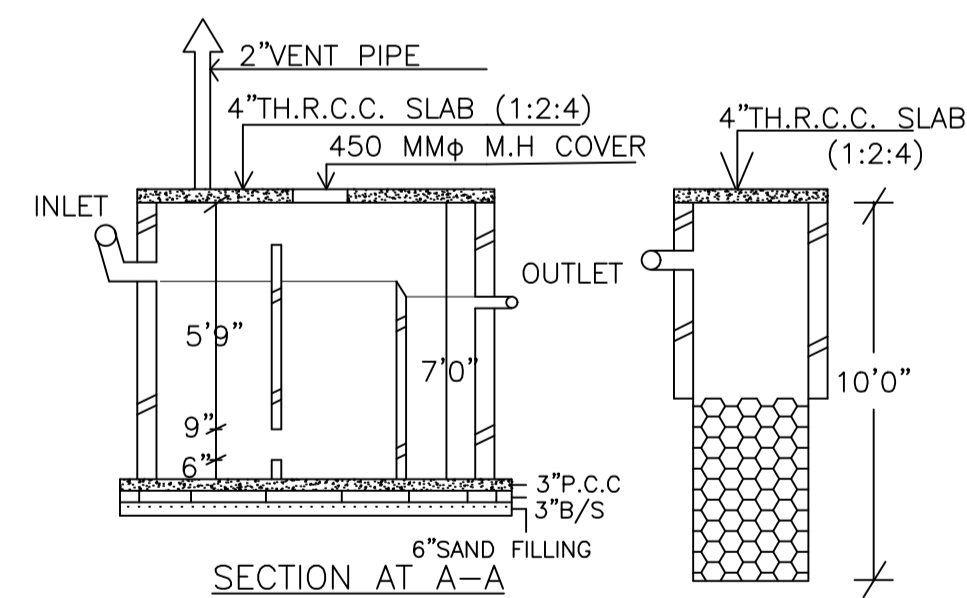

SECTION AT A-A

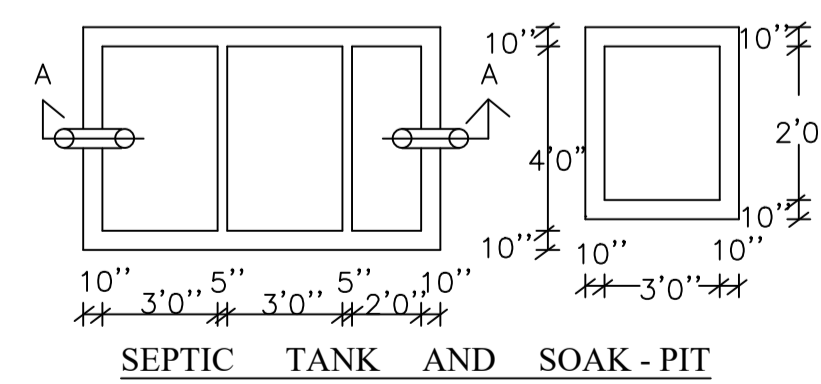

SEPTIC TANK AND SOAK-PIT

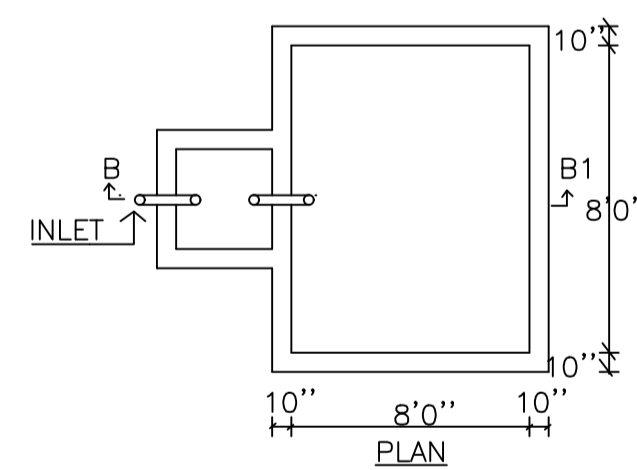

PLAN

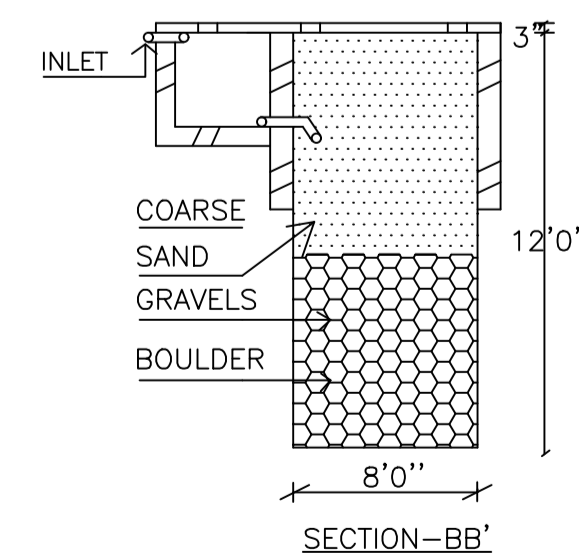

SECTION-BB'

RAIN WATER HARVESTING SCHEME

Building :A (SMT BINDU KUMARI)

Floor Name	Total Built Up Area (Sq.mt.)	Deductions (Area in Sq.mt.)	Proposed FAR Area (Sq.mt.)	Total FAR Area (Sq.mt.)	Total Consumed Additional FAR Area (Sq.mt.)	Tnmt (No.)
		Parking	Resi.			
Ground Floor	86.44	26.05	60.39	60.39	60.39	01
First Floor	86.44	0.00	86.44	86.44	86.44	00
Terrace Floor	0.00	0.00	0.00	0.00	0.00	00
Total :	172.88	26.05	146.83	146.83	146.83	01
Total Number of Same Buildings :	1					
Total :	172.88	26.05	146.83	146.83	146.83	01

SCHEDULE OF DOOR:

BUILDING NAME	NAME	LENGTH	HEIGHT	NOS
A (SMT BINDU KUMARI)	D2	0.75	2.13	03
A (SMT BINDU KUMARI)	D1	0.91	2.13	06
A (SMT BINDU KUMARI)	D	0.95	2.13	02

SCHEDULE OF WINDOW/VENTILATION:

BUILDING NAME	NAME	LENGTH	HEIGHT	NOS
A (SMT BINDU KUMARI)	V	0.70	2.70	02
A (SMT BINDU KUMARI)	V1	0.70	2.70	01
A (SMT BINDU KUMARI)	W	1.80	2.70	09
A (SMT BINDU KUMARI)	W1	1.80	2.70	03

UnitBUA Table for Building :A (SMT BINDU KUMARI)

FLOOR	Name	UnitBUA Type	UnitBUA Area	Carpet Area	No. of Rooms	No. of Tenement
GROUND FLOOR PLAN	SPLIT A	FLAT	109.50	109.39	3	1
FIRST FLOOR PLAN	SPLIT A	FLAT	0.00	0.00	7	0
Total:	-	-	109.50	109.39	10	1

LTP NAME AND SIGNATURE	STRUCTURAL ENG'S NAME AND SIGNATURE	BUILDER NAME AND SIGNATURE	DIGITAL SIGNATURE
ALOK KUMAR SINGH DGMC/ENG/0007/2017			