

Project Title : RESIDENCE OF JITESH ANAND

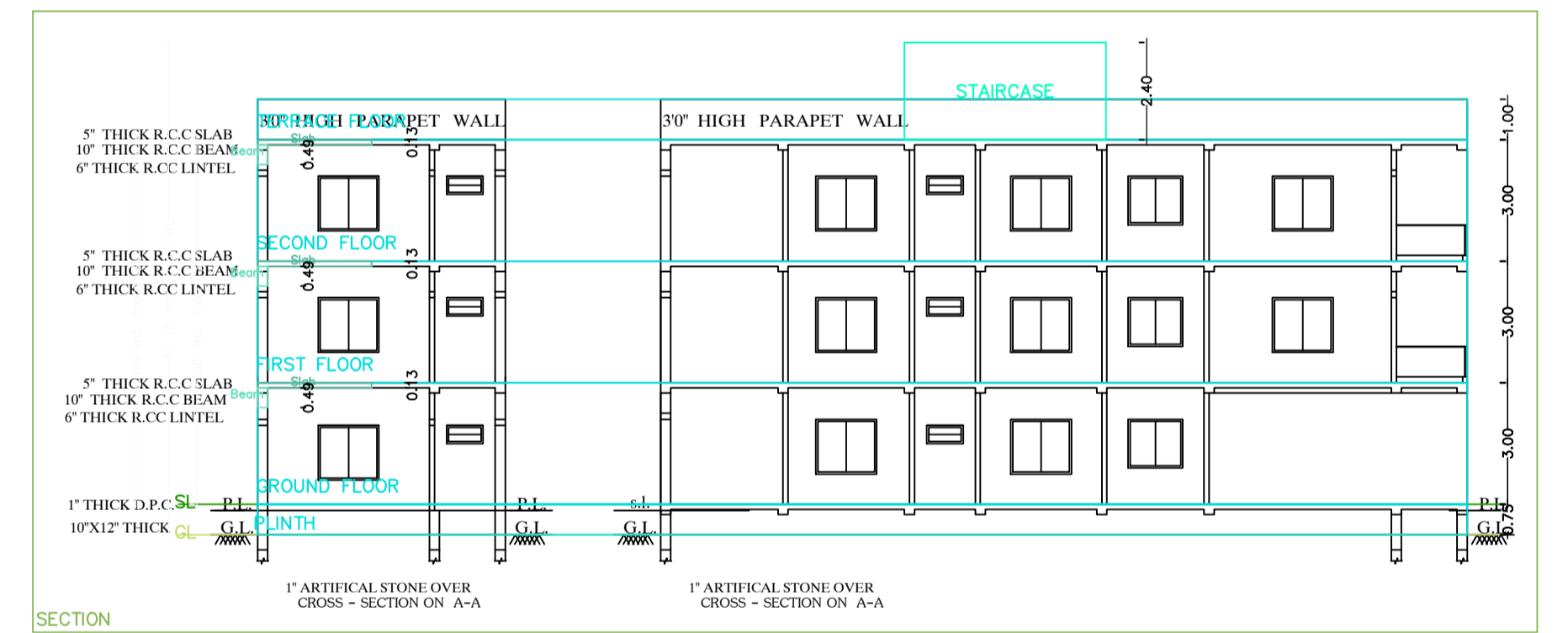
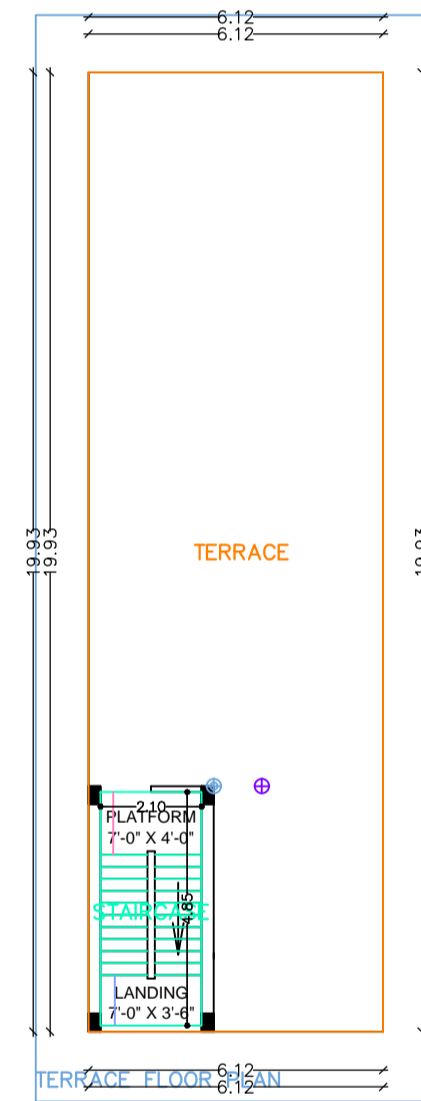
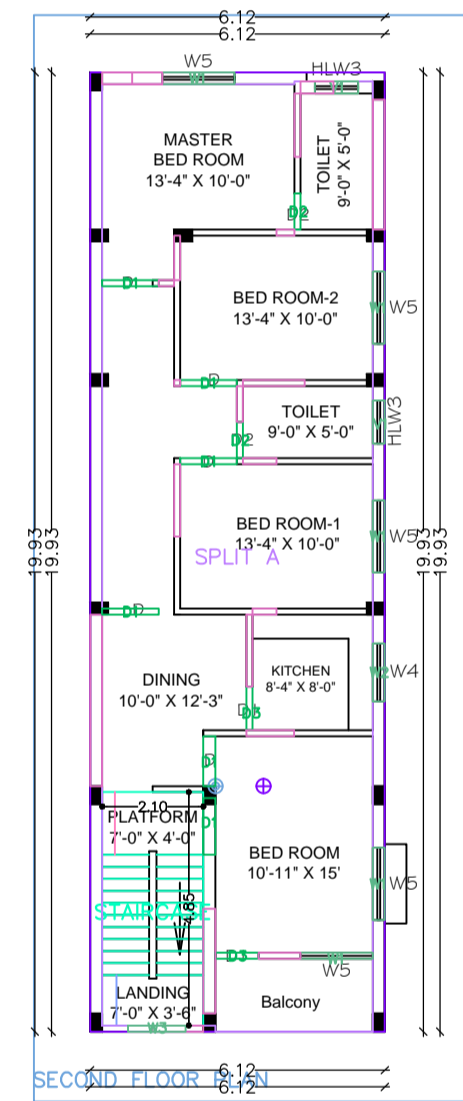
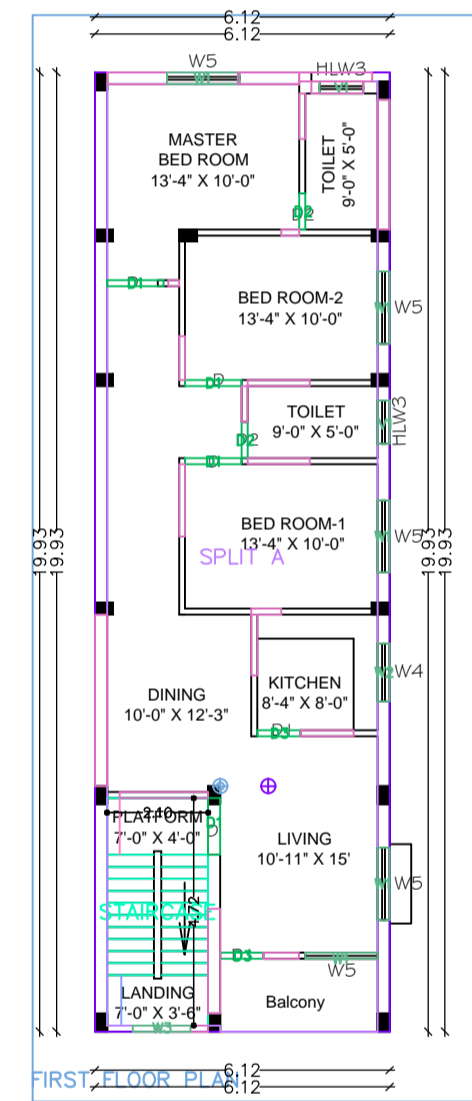
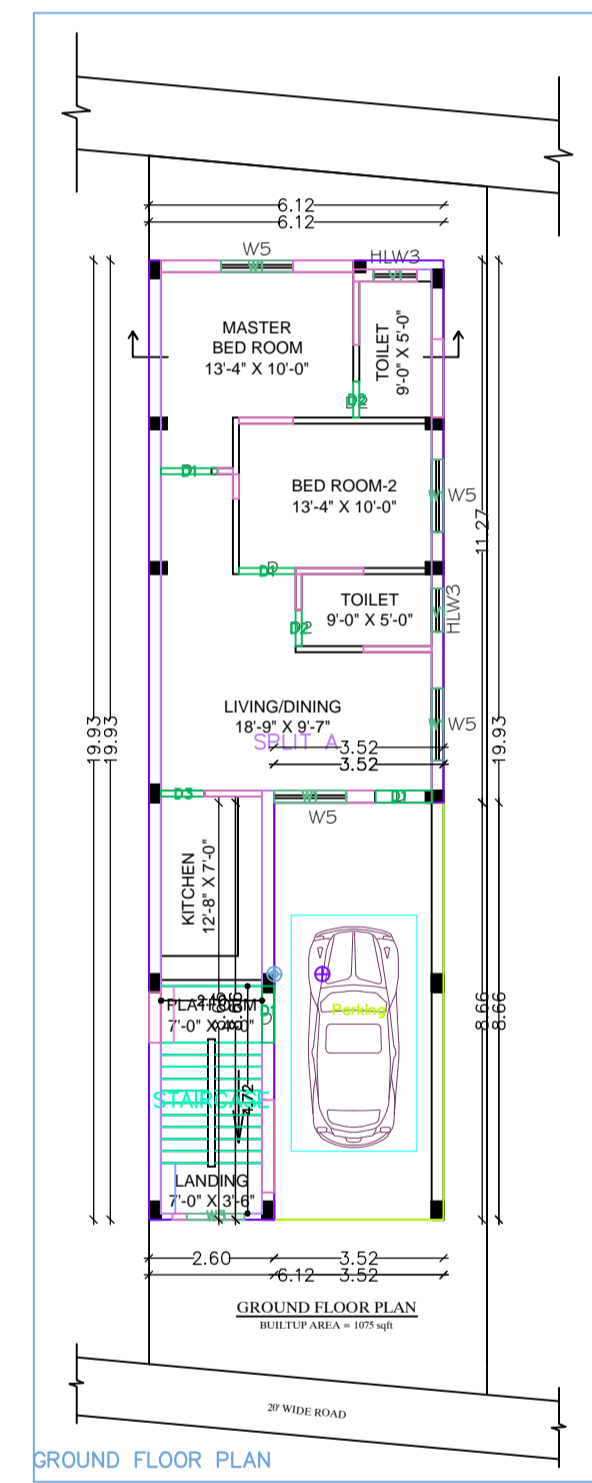
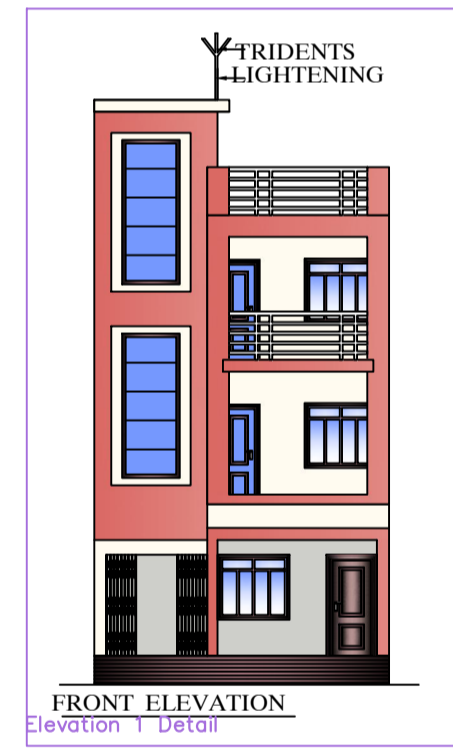
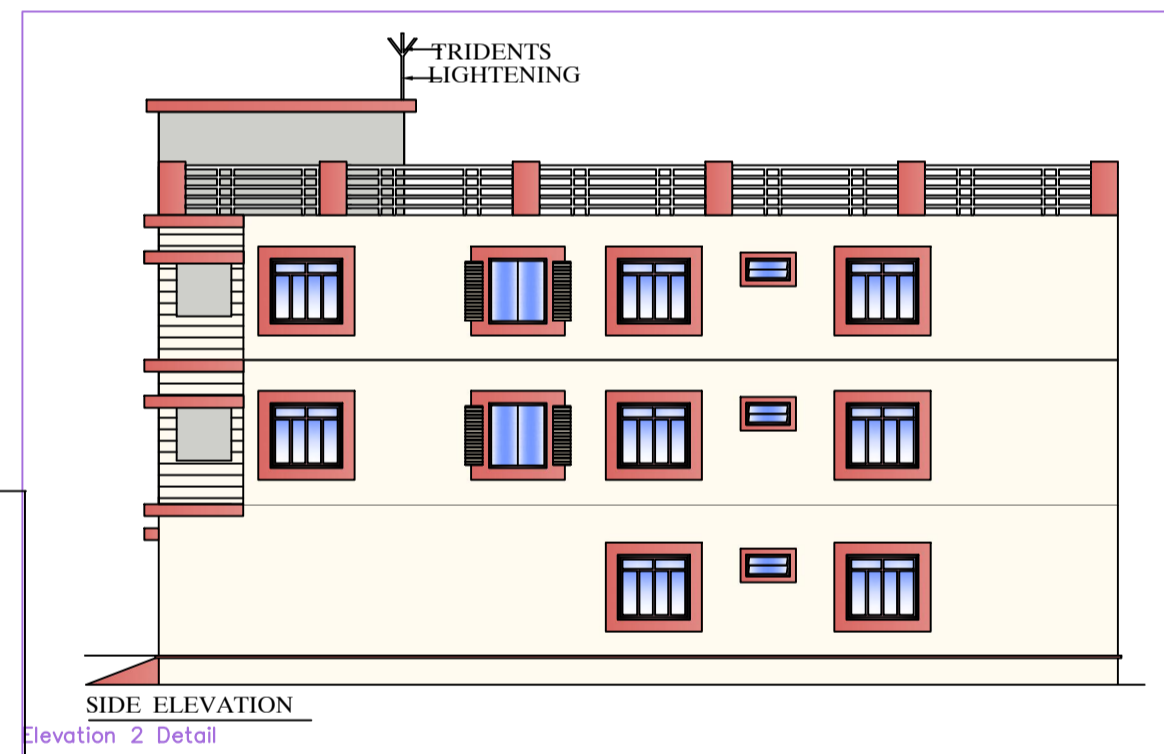
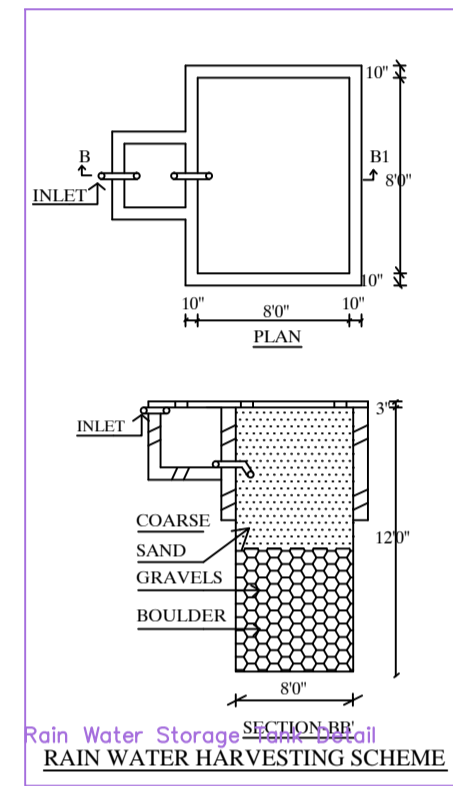
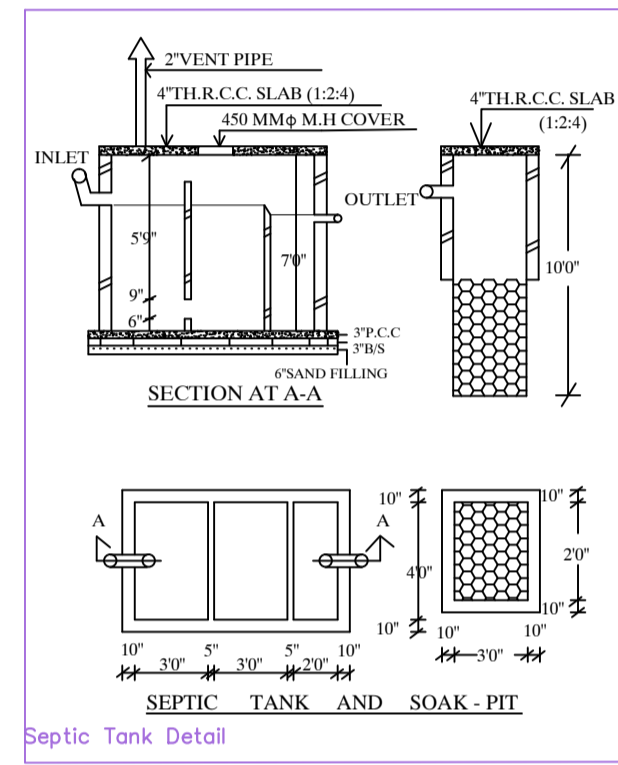

PROPOSED RESIDENTIAL BUILDING FOR
 JITESH ANAND S/O NAND KISHOR
 PRASAD SAH
 LAND UNDER MOUZA :-NOORPUR
 HOLDING NO.-0220002438000M0,
 WARD NO :- 22, J.B.NO-236/2/KH PART
 OF T.P PLOT NO.-189, THANA NO-415
 P.S.- DEOGHAR, DISTRICT :- DEOGHAR,
 PIN-814112, JHARKHAND.