

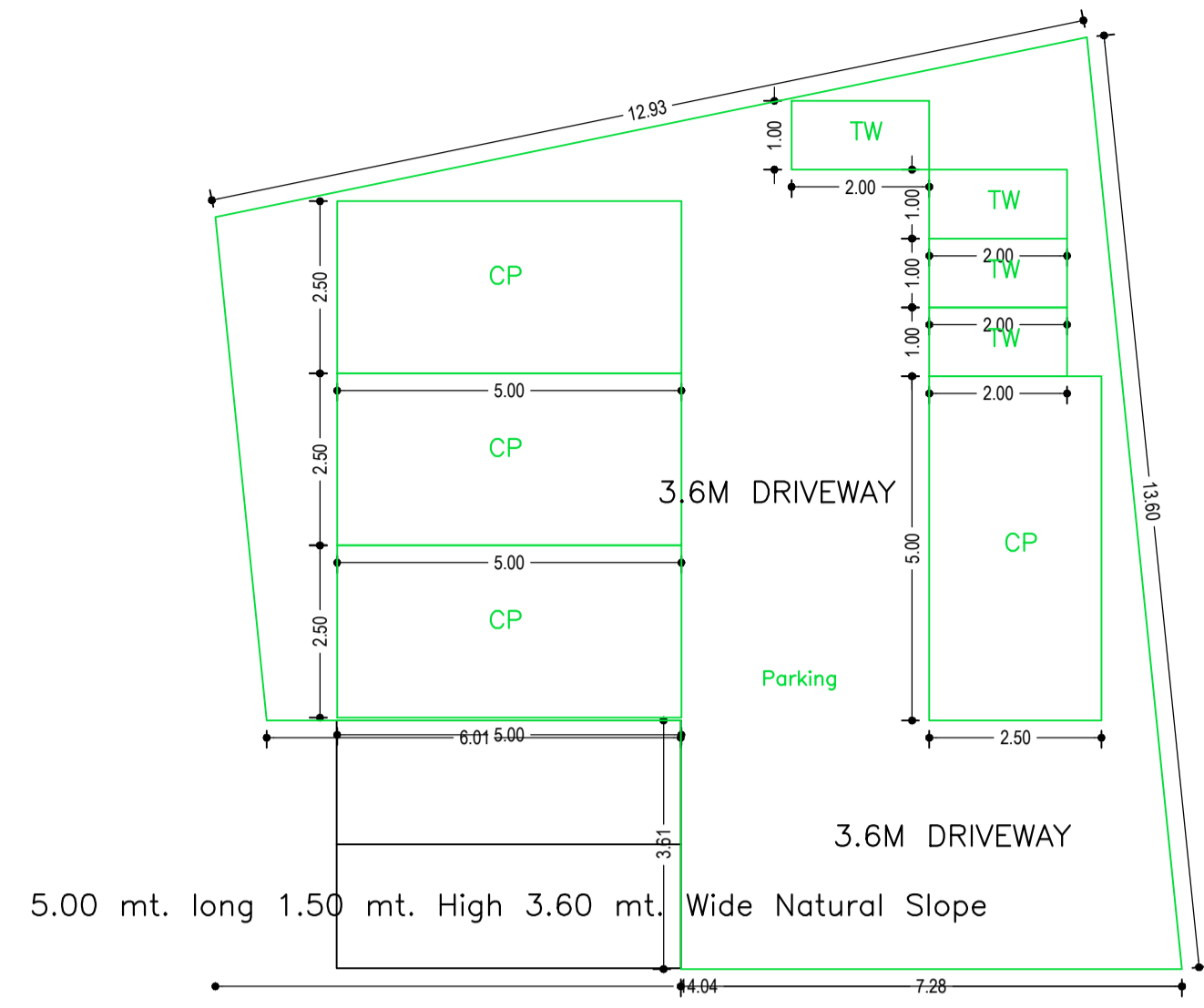

Proposal Basic Information	
Proposal File No.	DGMC/BP/0060/W07/2021
Owner Name	SNEHASISH CHAKRABORTY AND JULI BANERJEE
Khata No	298/3035 kha/a
Plot No	510
Village Name	Deoghar
Use	Residential
SubUse	Residential Bldg/Apartment

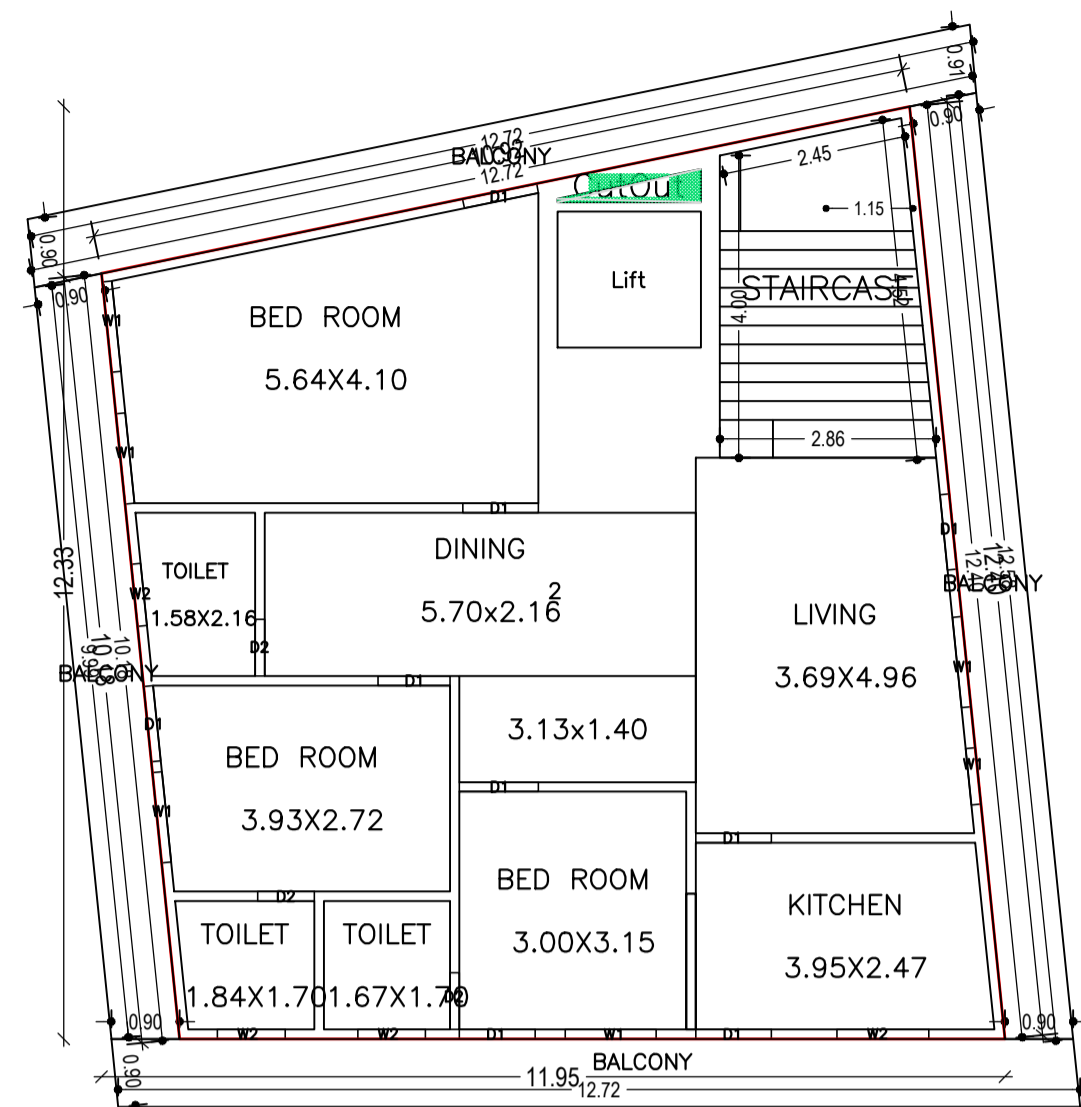

BASEMENT FLOOR PLAN (SCALE 1:100)



TYPICAL - 1, 2& 3 FLOOR PLAN (Proposed) (SCALE 1:100)

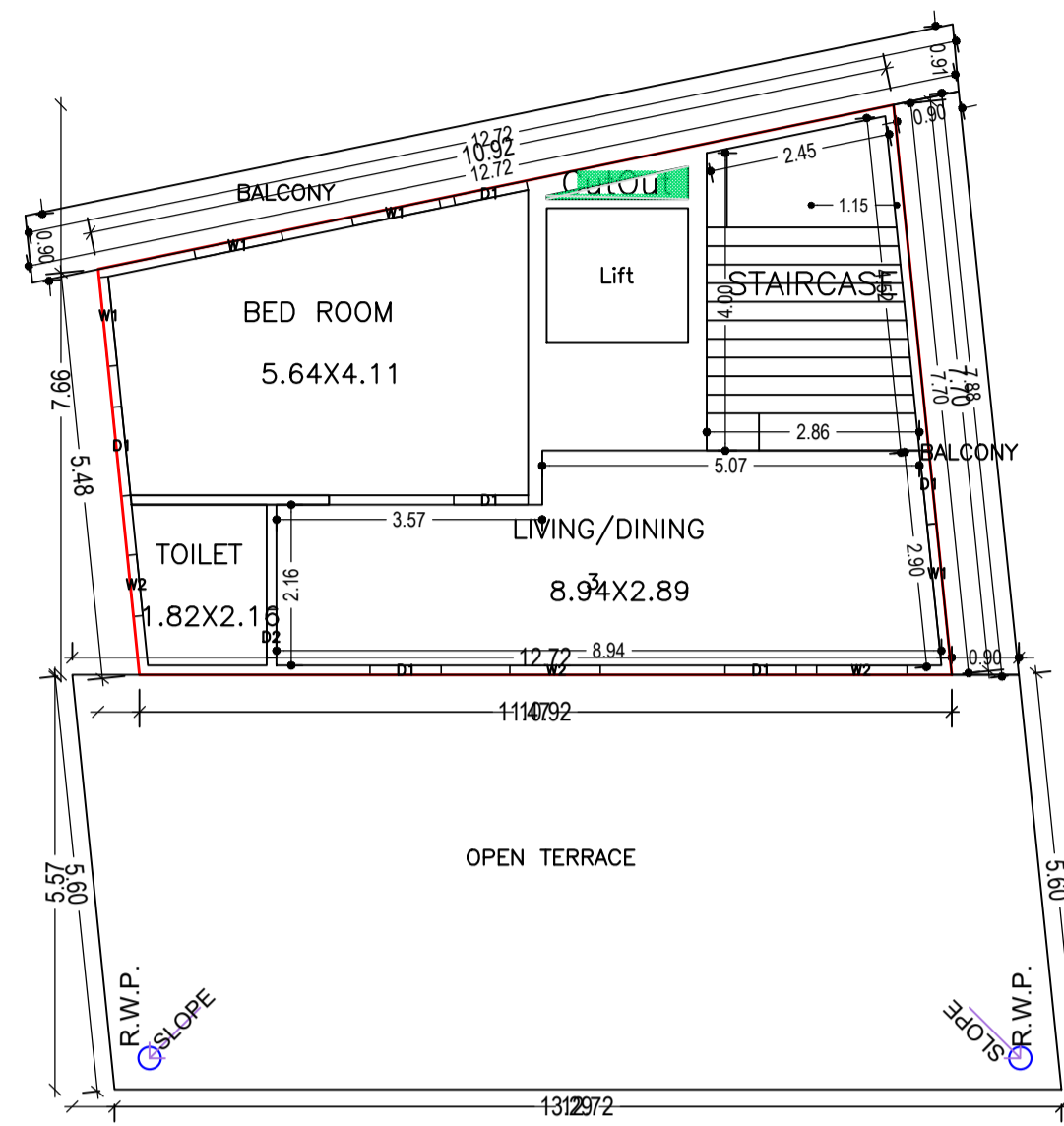

FOURTH FLOOR PLAN (Proposed) (SCALE 1:100)

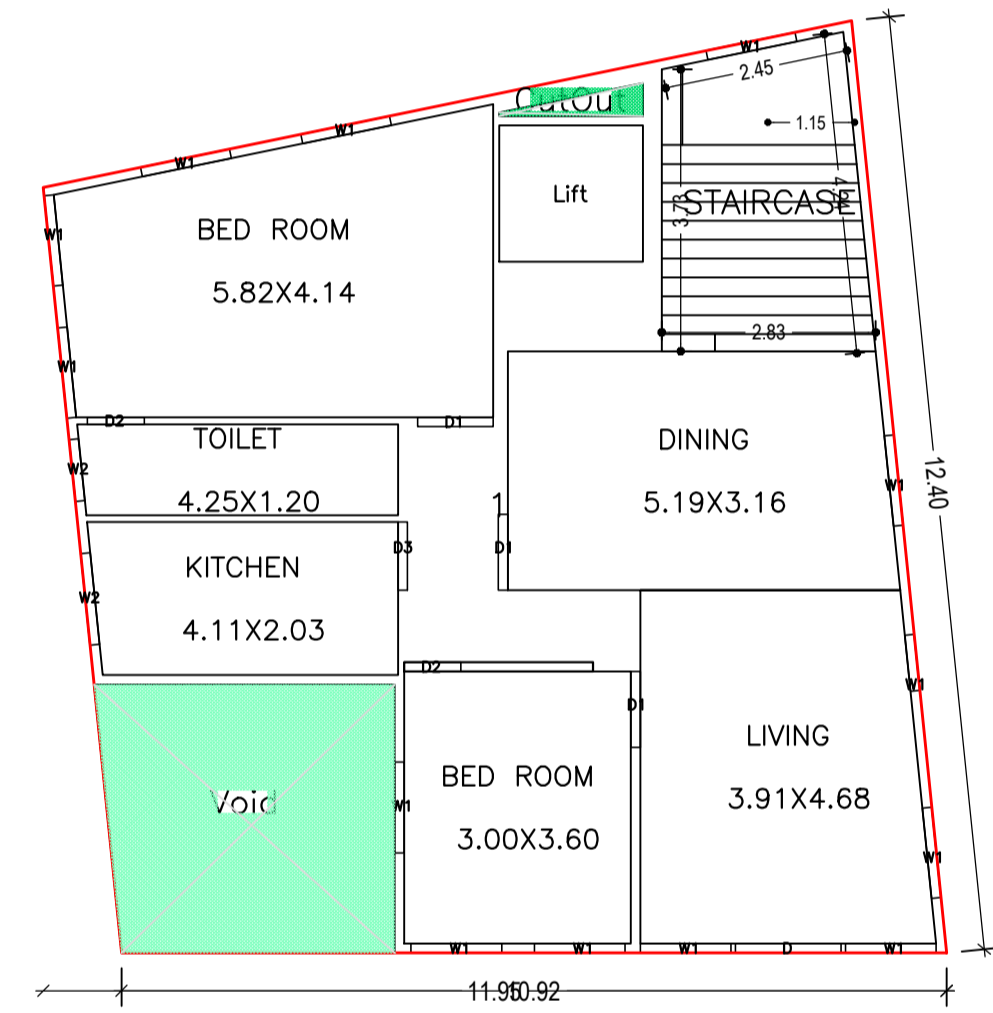
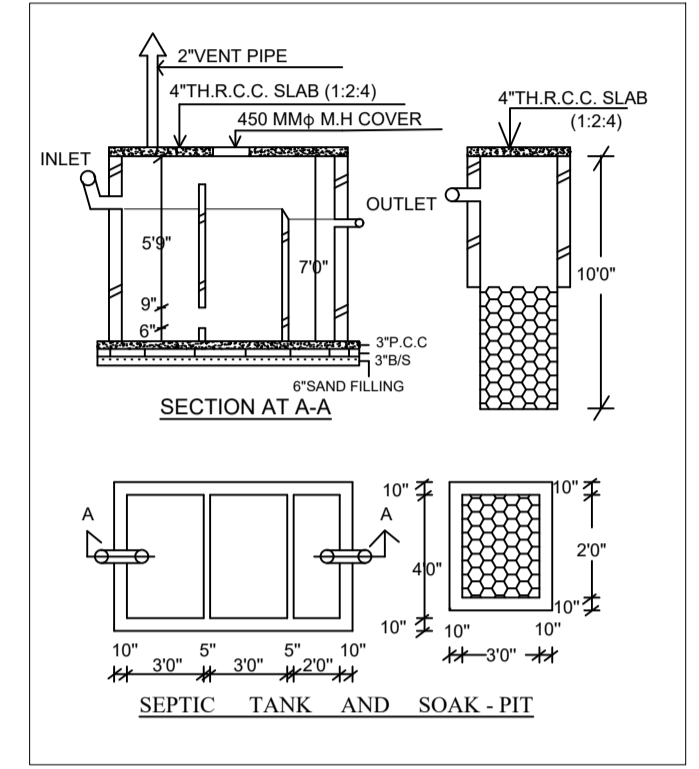

GROUND FLOOR PLAN (Proposed) (SCALE 1:100)

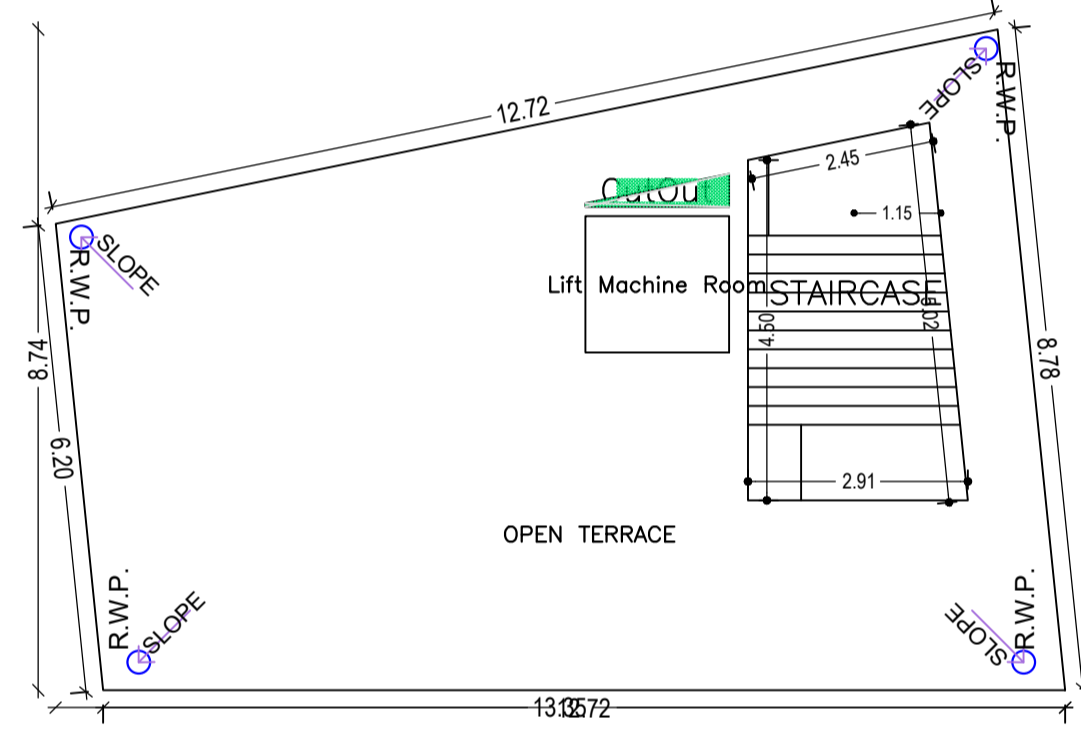

TERRACE FLOOR PLAN (SCALE 1:100)

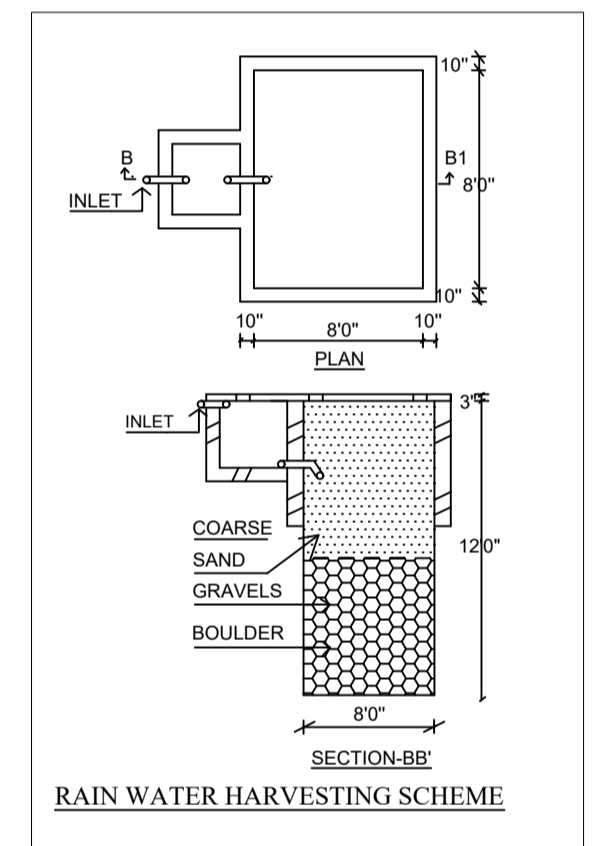
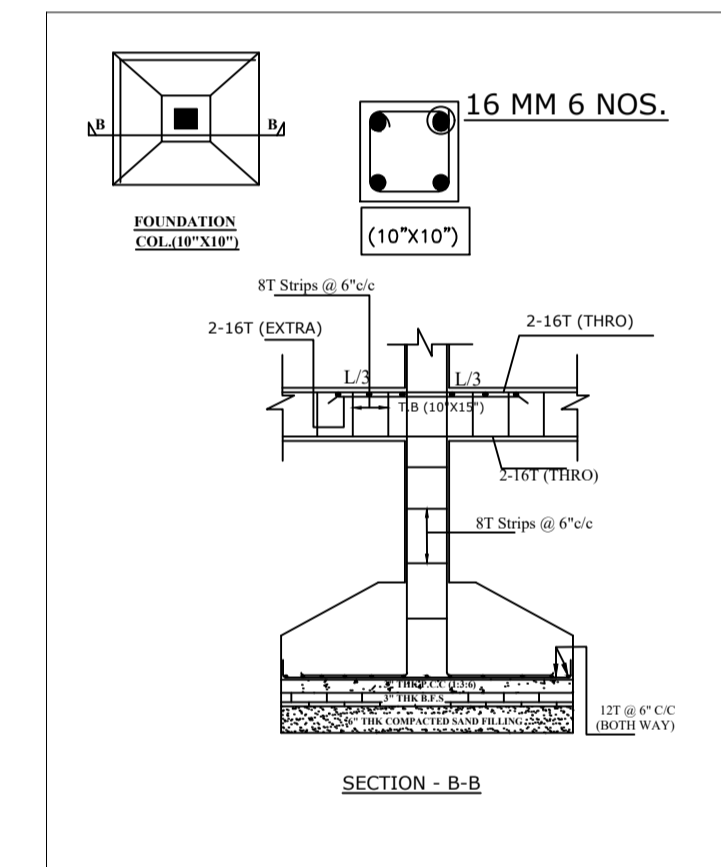
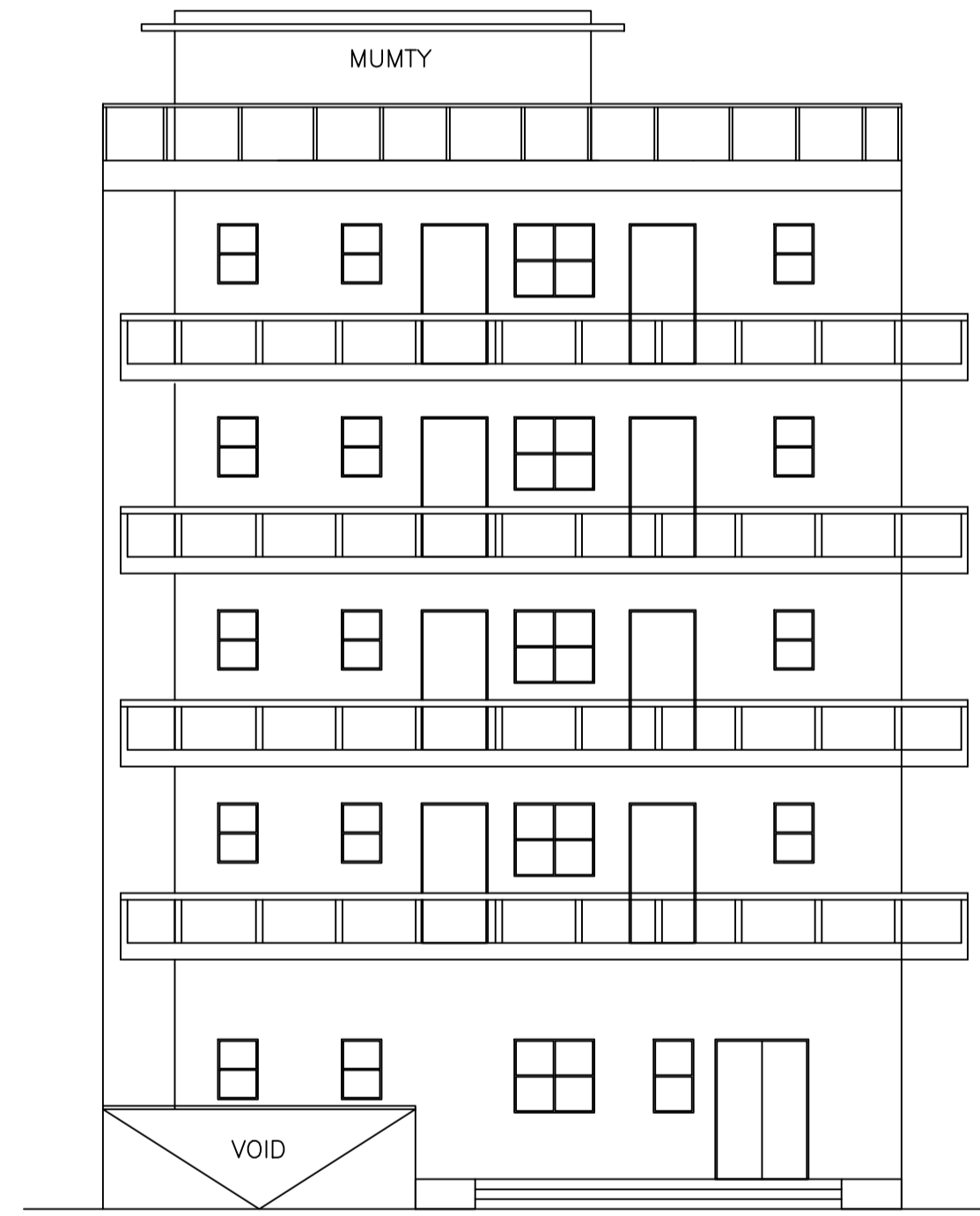

SCHEDULE OF DOOR:

BUILDING NAME	NAME	LENGTH	HEIGHT	NOS
RESI (SNEHASISH CHAKRABORTY AND JULI BANERJEE)	D2	0.65	2.10	01
RESI (SNEHASISH CHAKRABORTY AND JULI BANERJEE)	D2	0.75	2.10	11
RESI (SNEHASISH CHAKRABORTY AND JULI BANERJEE)	D3	0.90	2.10	01
RESI (SNEHASISH CHAKRABORTY AND JULI BANERJEE)	D1	0.95	2.10	05
RESI (SNEHASISH CHAKRABORTY AND JULI BANERJEE)	D1	1.00	2.10	27
RESI (SNEHASISH CHAKRABORTY AND JULI BANERJEE)	D1	1.05	2.10	03
RESI (SNEHASISH CHAKRABORTY AND JULI BANERJEE)	D1	1.20	2.10	01
RESI (SNEHASISH CHAKRABORTY AND JULI BANERJEE)	D	1.40	2.10	01

SCHEDULE OF WINDOW/VENTILATION:

BUILDING NAME	NAME	LENGTH	HEIGHT	NOS
RESI (SNEHASISH CHAKRABORTY AND JULI BANERJEE)	W1	0.75	1.20	04
RESI (SNEHASISH CHAKRABORTY AND JULI BANERJEE)	W2	0.82	1.20	05
RESI (SNEHASISH CHAKRABORTY AND JULI BANERJEE)	W2	0.90	1.20	06
RESI (SNEHASISH CHAKRABORTY AND JULI BANERJEE)	W1	1.20	1.20	30
RESI (SNEHASISH CHAKRABORTY AND JULI BANERJEE)	W2	1.21	1.20	06
RESI (SNEHASISH CHAKRABORTY AND JULI BANERJEE)	W1	1.81	1.20	01

Balcony Calculations Table

FLOOR	SIZE	AREA	TOTAL AREA
TYPICAL - 1, 2& 3 FLOOR PLAN	0.90 X 12.73 X 2 X 3	68.70	129.48
	0.90 X 12.58 X 1 X 3	33.54	
	0.90 X 10.18 X 1 X 3	27.24	
FOURTH FLOOR PLAN	0.90 X 12.73 X 1 X 1	11.45	18.42
	0.90 X 7.88 X 1 X 1	6.97	
Total	-	-	147.90

Building :RESI (SNEHASISH CHAKRABORTY AND JULI BANERJEE)

Floor Name	Gross Builtup Area	Deductions From Gross BUA(Area in Sq.mt.)	Total Built Up Area (Sq.mt.)	Deductions (Area in Sq.mt.)				Proposed FAR Area (Sq.mt.)	Total FAR Area (Sq.mt.)	Total Consumed FAR Area (Sq.mt.)	Tnmt (No.)
				Lift	Balcony	Void	Parking				
Basement Floor	137.01	0.00	137.01	0.00	0.00	0.00	137.01	0.00	0.00	0.00	00
Ground Floor	122.55	0.46	122.09	3.42	0.00	13.47	0.00	105.20	105.20	105.20	01
First Floor	165.71	0.46	165.25	3.42	21.58	0.00	0.00	140.25	140.25	140.25	01
Second Floor	165.71	0.46	165.25	3.42	21.58	0.00	0.00	140.25	140.25	140.25	01
Third Floor	165.71	0.46	165.25	3.42	21.58	0.00	0.00	140.25	140.25	140.25	01
Fourth Floor	89.94	0.46	89.48	3.42	9.21	0.00	0.00	76.85	76.85	76.85	01
Terrace Floor	0.00	0.00	0.00	0.00	0.00	0.00	0.00	0.00	0.00	0.00	00
Total :	846.63	2.30	844.33	17.10	73.95	13.47	137.01	602.80	602.80	602.80	05
Total Number of Same Buildings	1										
Total :	846.63	2.30	844.33	17.10	73.95	13.47	137.01	602.80	602.80	602.80	05

UnitBUA Table for Building :RESI (SNEHASISH CHAKRABORTY AND JULI BANERJEE)

FLOOR	Name	UnitBUA Type	UnitBUA Area	Carpet Area	No. of Rooms	No. of Tenement
GROUND FLOOR PLAN	1	FLAT	99.67	99.36	6	1
TYPICAL - 1, 2& 3 FLOOR PLAN	2	FLAT	113.19	112.96	9	3
FOURTH FLOOR PLAN	3	FLAT	63.33	63.00	3	1
Total:	-	-	502.56	501.24	36	5

LTP NAME AND SIGNATURE	STRUCTURAL ENG'S NAME AND SIGNATURE	BUILDER NAME AND SIGNATURE	DIGITAL SIGNATURE
RAMESH CHANDRA DGMC/ENG0021/2017			