

Proposal Basic Information	
Proposal File No.	DGMC/BP/0107/W18/2022
Owner Name	VINA JHA
Khata No	935
Plot No	TPP No. 750
Village Name	Deoghar
Use	Residential
SubUse	Bungalow/ Dwelling / Non Apartment

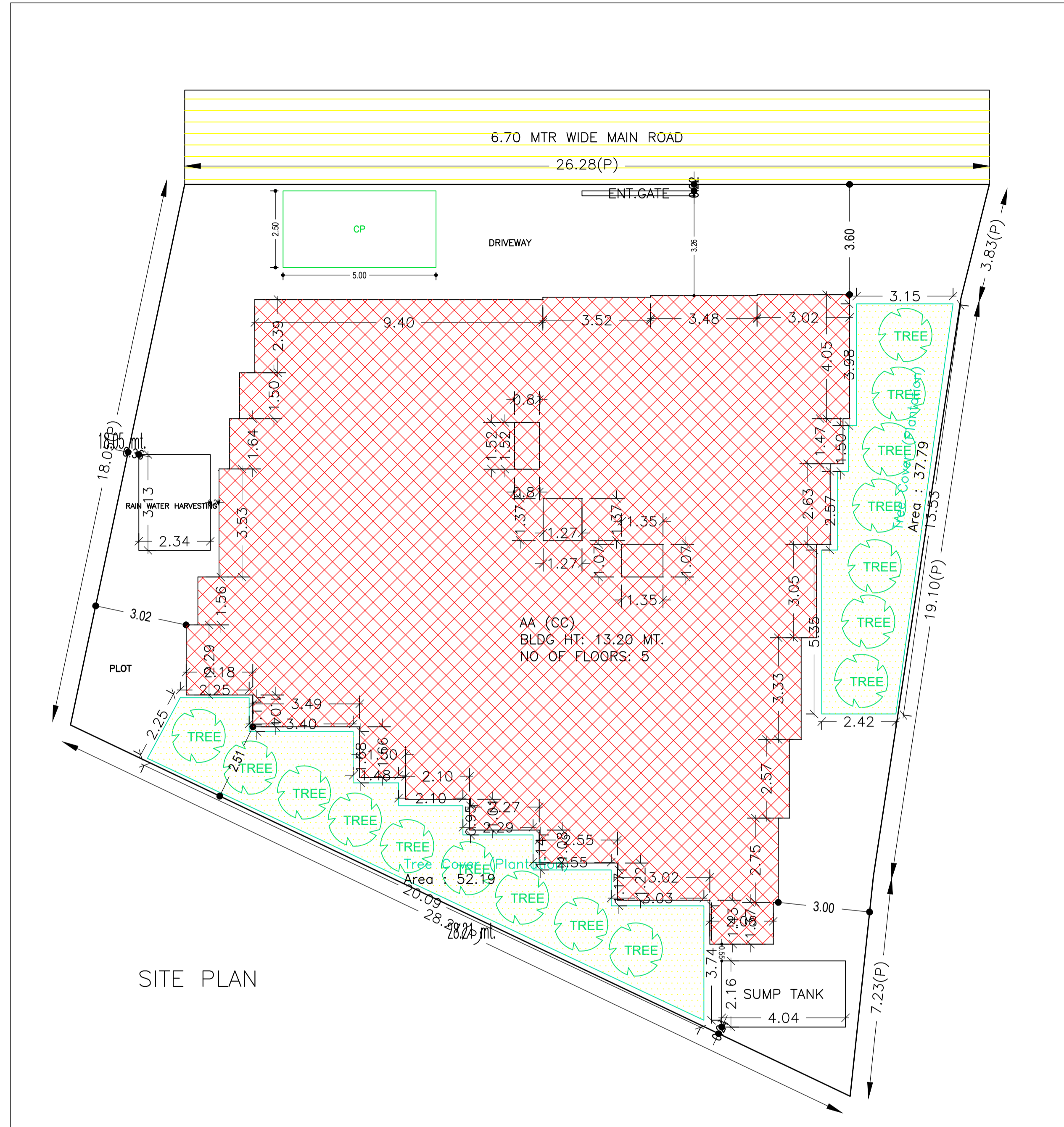
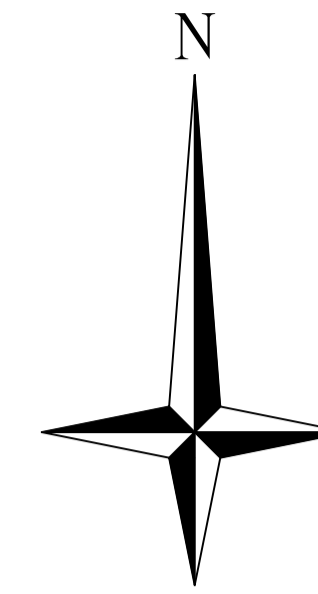

COLOR INDEX	
PLOT BOUNDARY	
ABUTTING ROAD	
PROPOSED CONSTRUCTION	
COMMON PLOT	
ROAD WIDENING AREA	
EXISTING (To be retained)	
EXISTING (To be demolished)	

Building USE/SUBUSE Details

Building Name	Building Use	Building SubUse	Building Structure
AA (CC)	Residential	Bungalow/ Dwelling / Non Apartment	Non-Highrise

Buildingwise Floor FAR Details

Floor Name	Building Name		Total	
	Proposed Built Up Area (Sq.mt.)	Proposed FAR Area (Sq.mt.)	Total Proposed Built Up Area (Sq.mt.)	Total FAR Area (Sq.mt.)
Ground Floor	332.92	147.02	332.92	147.02
First Floor	332.88	329.72	332.88	329.72
Second Floor	362.43	339.99	362.43	339.99
Third Floor	362.43	339.99	362.43	339.99
Fourth Floor	362.43	339.99	362.43	339.99
Terrace Floor	0.00	0.00	0.00	0.00
<b>Total :</b>	<b>1753.09</b>	<b>1496.71</b>	<b>1753.09</b>	<b>1496.71</b>

AREA STATEMENT	DEOGHAR MUNICIPAL CORPORATION	VERSION NO.: 1.0.66
PROJECT DETAIL:	Region: JHARKHAND URBAN LOCAL BODIES	Plot Use: Residential
Authority: DEOGHAR MUNICIPAL CORPORATION	District: DEOGHAR	Plot SubUse: Bungalow/ Dwelling / Non Apartment
Inward No: DGMC/BP/0107/W18/2022	Application Type: General Proposal	Plot/SubPlot No: TPP No. 750
Project Type: Building Permission	Nature of Development: New	North: Road Width - 6.7
Location of Development Area: Old Area	Location of Development Area: Old Area	South: Plot No. - VENDOR LAND
		East: Plot No. - OTHER'S PLOT
		West: Plot No. - OTHER'S PLOT
AREA DETAILS:		SQ.MT.
AREA OF PLOT (Minimum)	(A)	630.41
NET AREA OF PLOT(Gross Plot Area - Deduction from Gross Plot area)	(A-Deductions)	630.41
Deduction for Balance Plot Area(from Gross Plot Area)		
Common Plot		89.98
Total		89.98
BALANCE AREA OF PLOT(Net Plot Area - Recreational/Amenity space)	(A-Deductions)	540.43
PLOT AREA FOR COVERAGE(Net Plot Area)	(A-Deductions)	630.41
Plot Area for FAR (Net Plot Area + RoadWidening Area)	(A-Deductions)	630.41
COVERAGE CHECK		
Permissible Coverage area ( 60.00 % )		378.25
Proposed Coverage Area ( 52.80 % )		332.88
Total Prop. Coverage Area ( 52.8 % )		332.88
Balance coverage area ( 7.20 % )		45.37
FAR CHECK		
Perm. FAR Area ( 2.500 )		1576.02
Total Perm. FAR area		1576.02
Residential FAR		1496.69
Proposed FAR Area		1496.69
Total Proposed FAR Area		1496.69
Consumed FAR (Factor)		2.37
Balance FAR Area		79.33
BUILT UP AREA CHECK		
Total Proposed BuiltUp Area		1753.09
ARCHITECT (Regd)		SIDHARTH
ENGINEER (Regd)		
SUPERVISOR (Regd)		
OWNER (Regd)		VINA JHA
DEVELOPMENT AUTHORITY		LOCAL BODY

Required Parking(Table 7a)

Building Name	Type	SubUse	Area (Sq.mt.)	Units		Car			Visitors Car		
				Reqd.	Prop.	Reqd./Unit	Reqd.	Prop.	Reqd./Unit	Reqd.	Prop.
AA (CC)	Residential	Bungalow/ Dwelling / Non Apartment	> 0	1	5.00	1.00	5	-	-	-	-
			> 0	1	5.00	-	-	-	1	1	-
<b>Total :</b>			-	-	-	-	5	5	-	1	1

Parking Check (Table 7b)

Vehicle Type	Reqd.		Prop.	
	No.	Area	No.	Area
Car	-	-	5	62.50
Total Car	5	62.50	5	62.50
Visitor's Car Parking	-	-	1	12.50
Total Visitor Parking	1	12.50	1	12.50
Other Parking	-	-	-	117.77
<b>Total</b>		<b>75.00</b>		<b>192.77</b>

FAR & Tenement Details (Table 4c-1)

Building	No. of Same Bldg	Gross Built Up Area (Sq.mt.)	Deductions From Gross BUA(Area in Sq.mt.)	Total Built Up Area (Sq.mt.)	Deductions (Area in Sq.mt.)				Proposed FAR Area (Sq.mt.)	Total FAR Area (Sq.mt.)	Total Consumed Additional FAR Area (Sq.mt.)	Tnmt (No.)
					Lift	Balcony	Accessory Use	Parking				
AA (CC)	1	1770.77	17.68	1753.09	22.52	40.95	12.64	180.27	1496.71	1496.71	1496.71	05
<b>Grand Total</b>	<b>1</b>	<b>1770.77</b>	<b>17.68</b>	<b>1753.09</b>	<b>22.52</b>	<b>40.95</b>	<b>12.64</b>	<b>180.27</b>	<b>1496.71</b>	<b>1496.71</b>	<b>1496.71</b>	<b>05</b>

LTP NAME AND SIGNATURE	STRUCTURAL ENG'S NAME AND SIGNATURE	BUILDER NAME AND SIGNATURE	DIGITAL SIGNATURE
SIDHARTH DGMC/ARC/0002/2016			

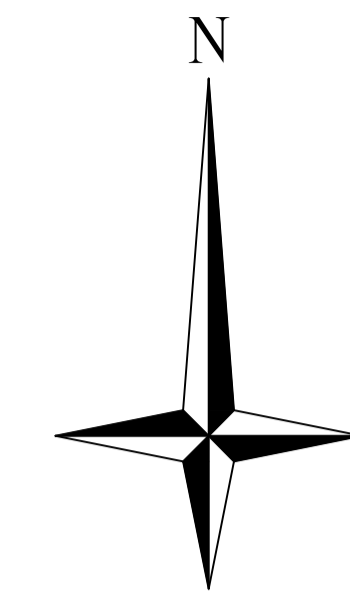

Proposal Basic Information	
Proposal File No.	DGMC/BP/0107/W18/2022
Owner Name	VINA JHA
Khata No	935
Plot No	TPP No. 750
Village Name	Deoghar
Use	Residential
SubUse	Bungalow/ Dwelling / Non Apartment

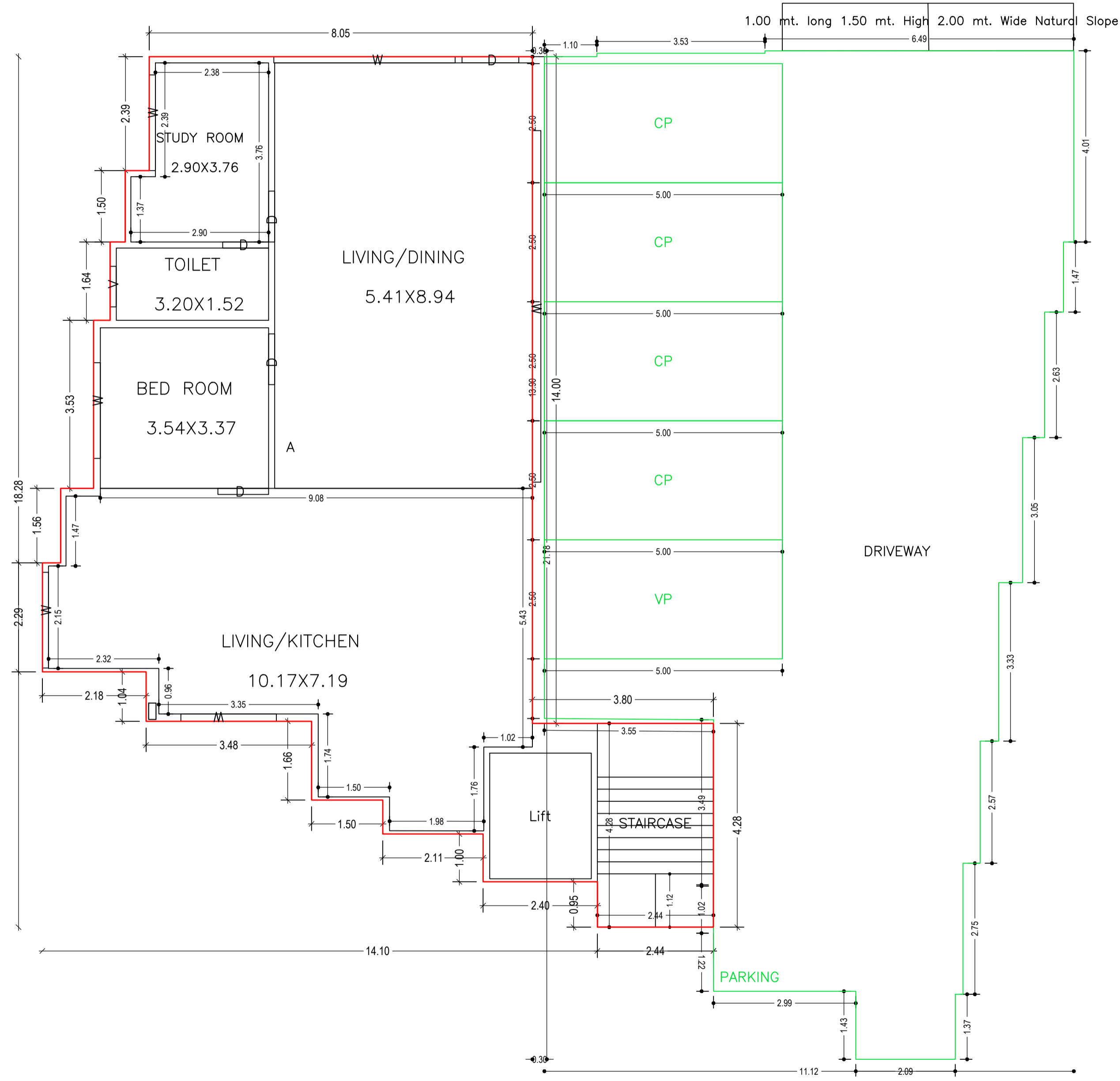

GROUND FLOOR PLAN  
(Proposed)  
(SCALE 1:100)

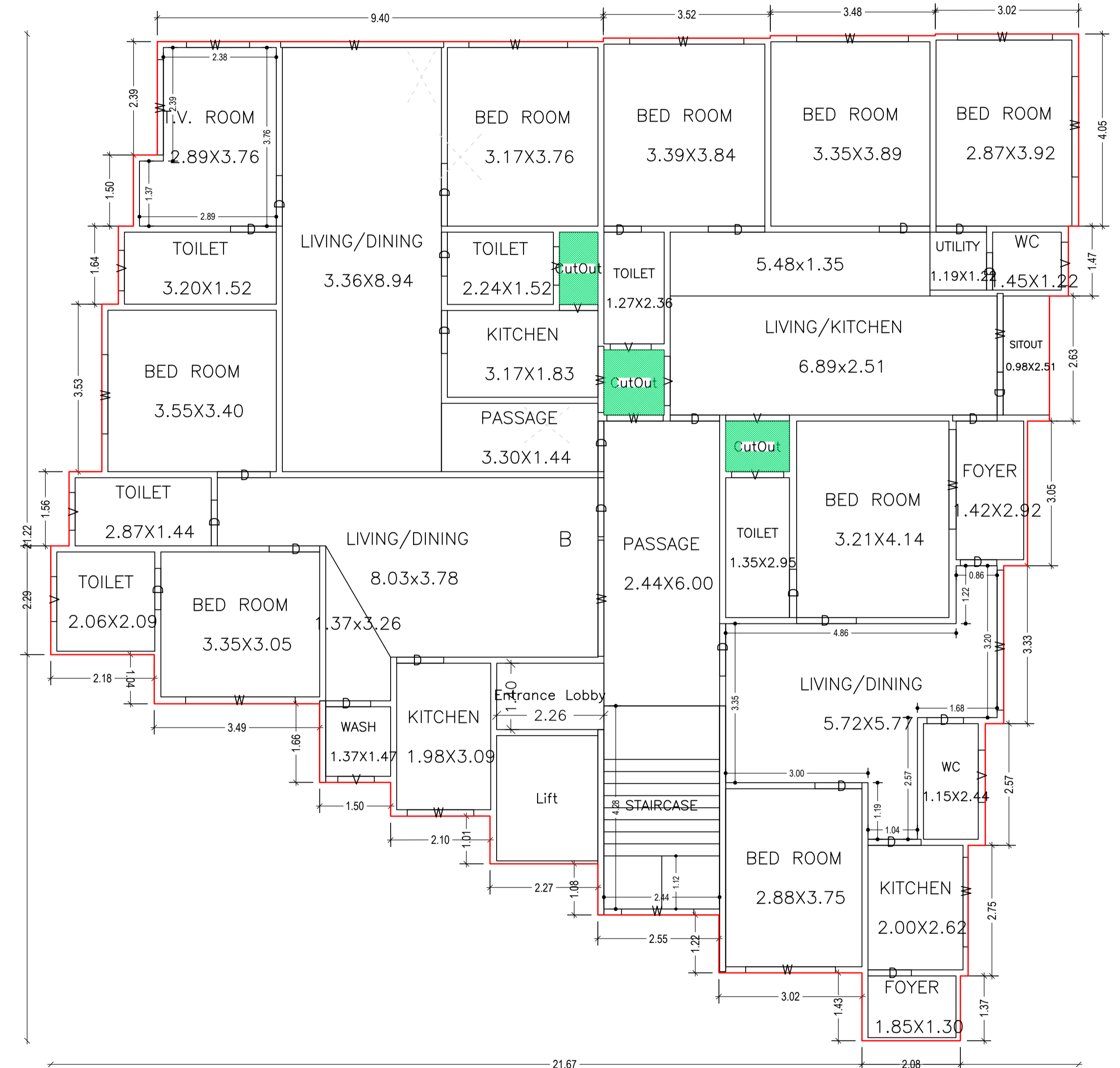

FIRST FLOOR PLAN  
(Proposed)  
(SCALE 1:100)

LTP NAME AND SIGNATURE	STRUCTURAL ENG'S NAME AND SIGNATURE	BUILDER NAME AND SIGNATURE	DIGITAL SIGNATURE
SIDHARTH DGMC/ARC/0002/2016			

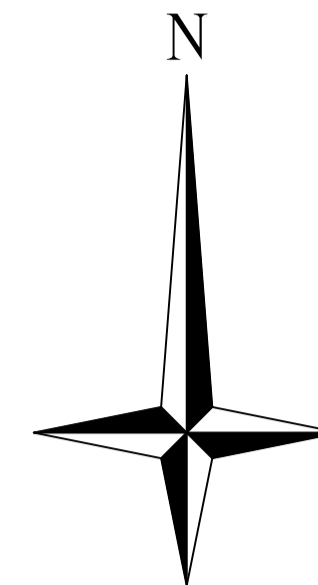

Proposal Basic Information	
Proposal File No.	DGMC/BP/0107/W18/2022
Owner Name	VINA JHA
Khata No	935
Plot No	TPP No. 750
Village Name	Deoghar
Use	Residential
SubUse	Bungalow/ Dwelling / Non Apartment

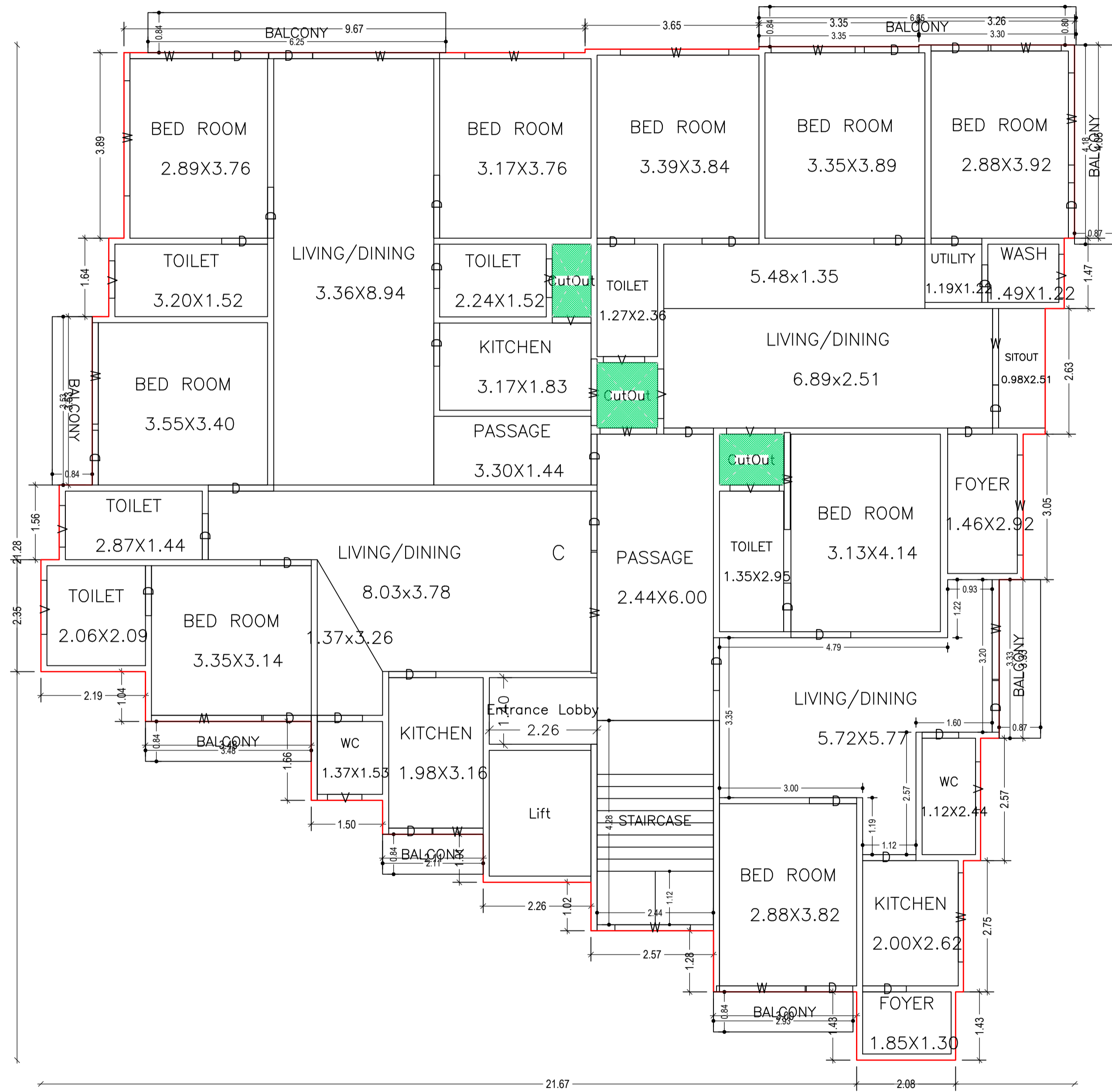

TYPICAL – 2, 3, 4 FLOOR PLAN  
(Proposed)  
(SCALE 1:100)

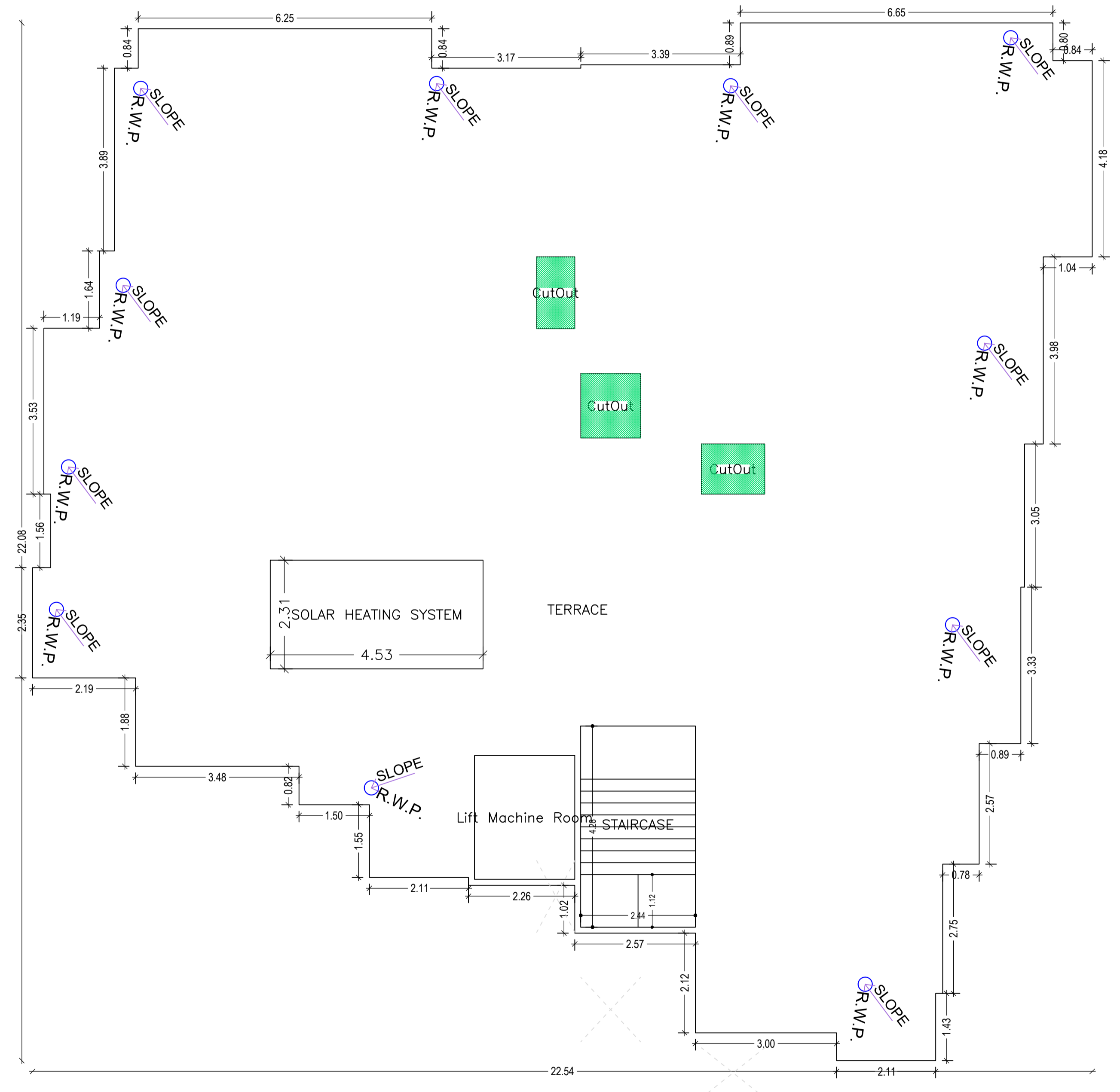

TERRACE FLOOR PLAN  
(SCALE 1:100)

LTP NAME AND SIGNATURE	STRUCTURAL ENG'S NAME AND SIGNATURE	BUILDER NAME AND SIGNATURE	DIGITAL SIGNATURE
SIDHARTH DGMC/ARC/0002/2016			

Proposal Basic Information	
Proposal File No.	DGMC/BP/0107/W18/2022
Owner Name	VINA JHA
Khata No	935
Plot No	TPP No. 750
Village Name	Deoghar
Use	Residential
SubUse	Bungalow/ Dwelling / Non Apartment

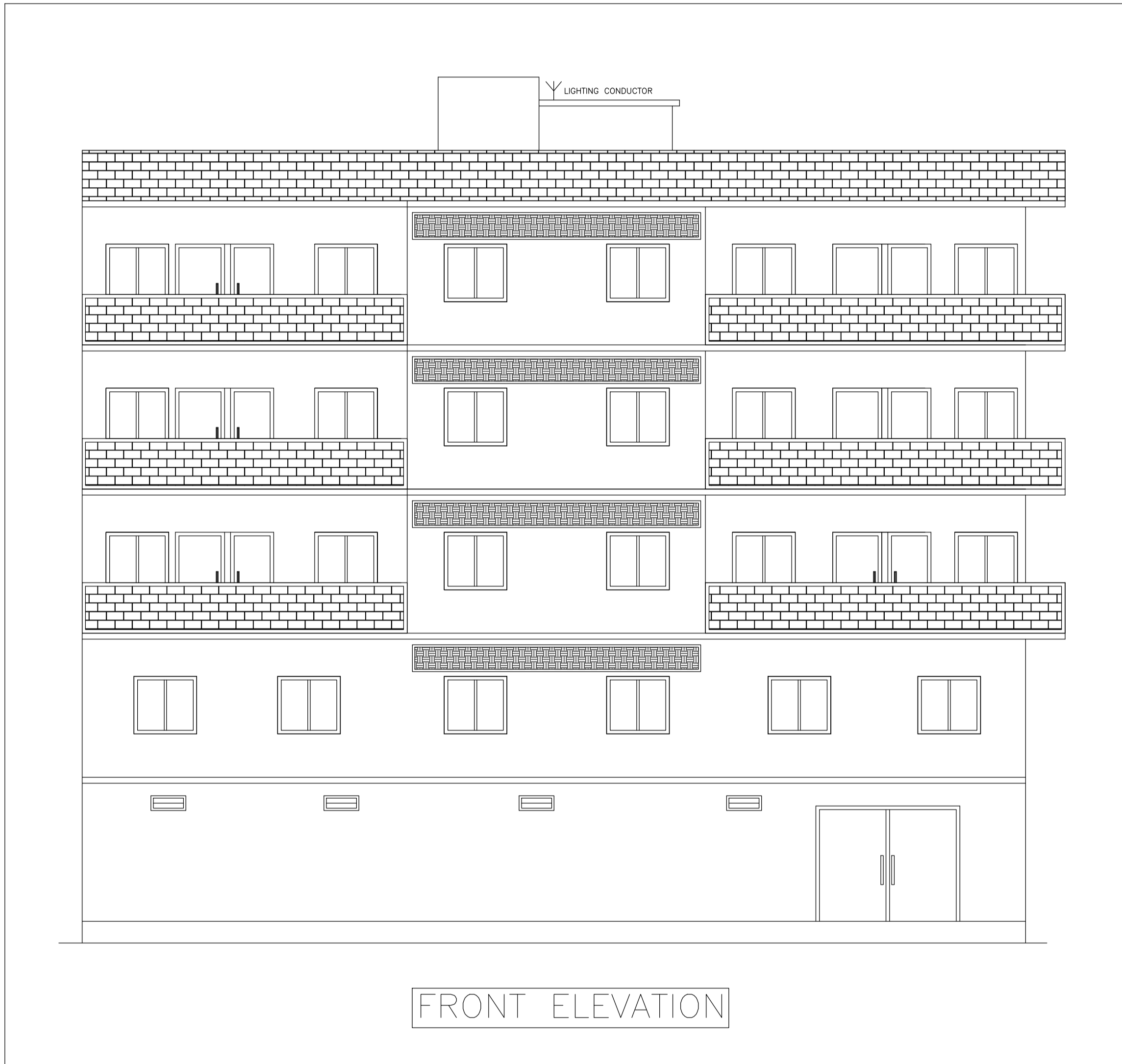
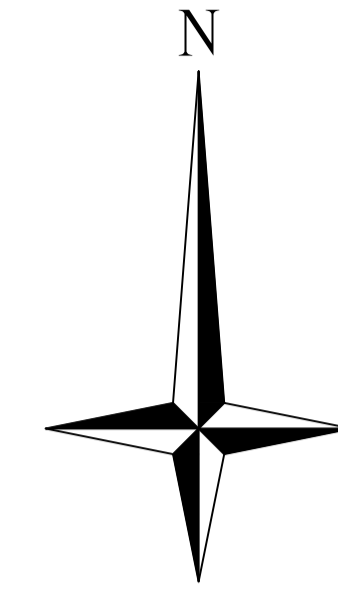

LTP NAME AND SIGNATURE	STRUCTURAL ENG'S NAME AND SIGNATURE	BUILDER NAME AND SIGNATURE	DIGITAL SIGNATURE
SIDHARTH DGMC/ARC/0002/2016			

Proposal Basic Information

Proposal File No.	DGMC/BP/0107/W18/2022
Owner Name	VINA JHA
Khata No	935
Plot No	TPP No. 750
Village Name	Deoghar
Use	Residential
SubUse	Bungalow/ Dwelling / Non Apartment

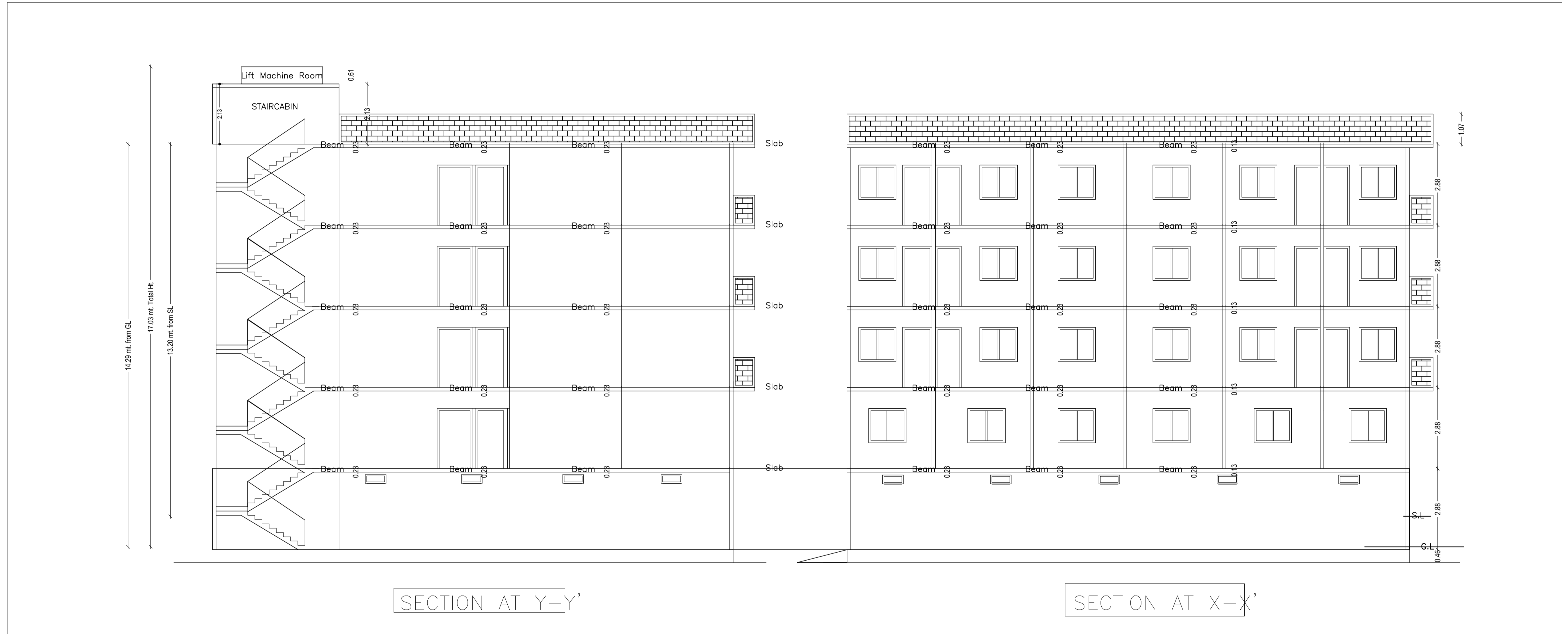
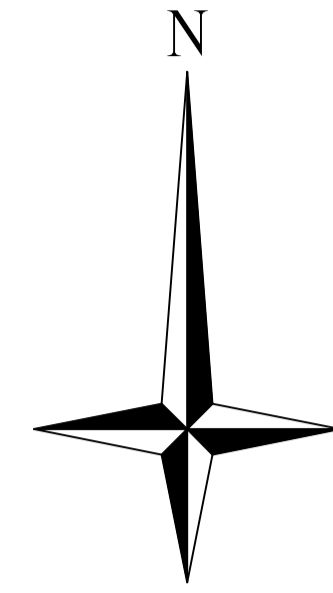

LTP NAME AND SIGNATURE	STRUCTURAL ENG'S NAME AND SIGNATURE	BUILDER NAME AND SIGNATURE	DIGITAL SIGNATURE
SIDHARTH DGMC/ARC/0002/2016			

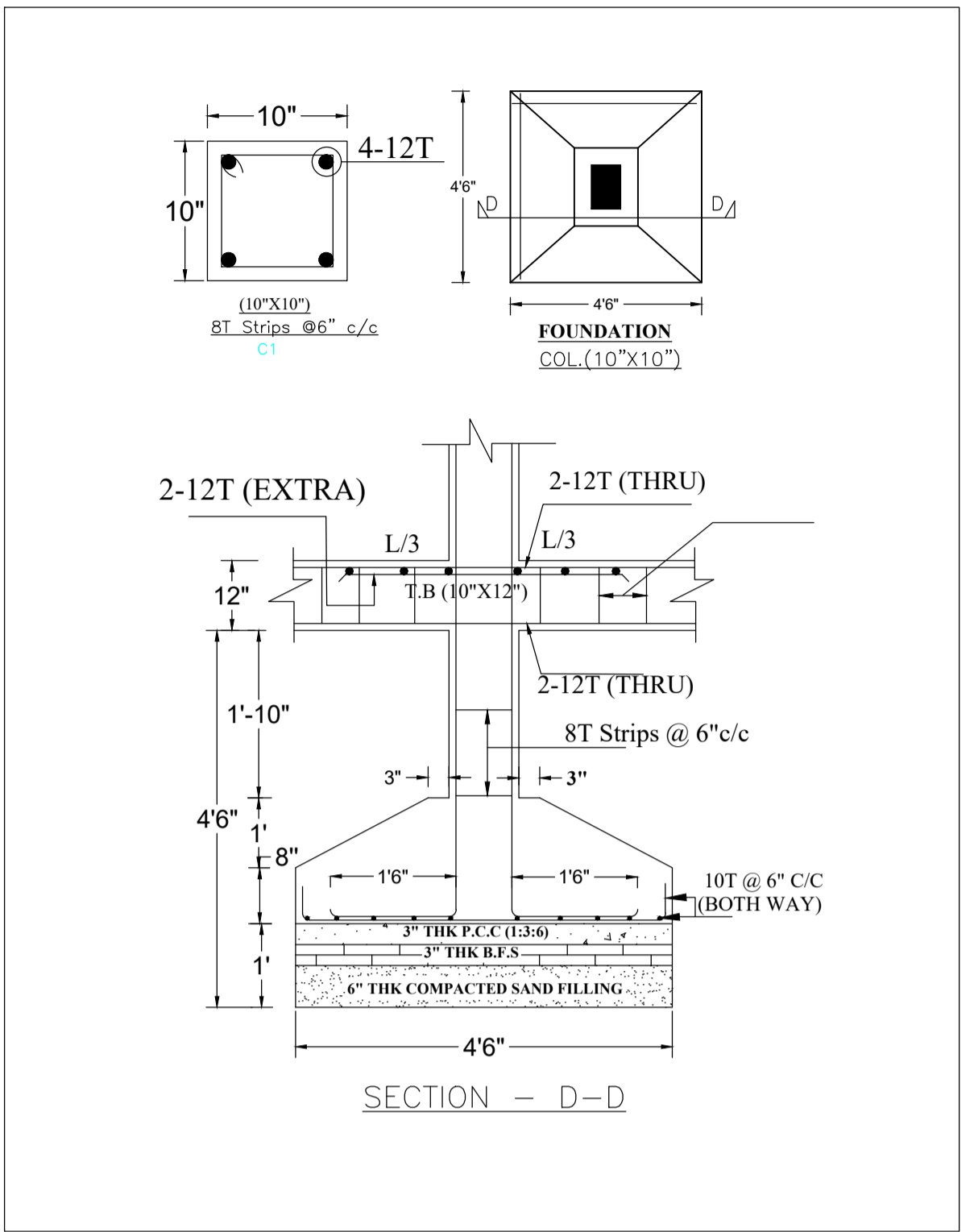
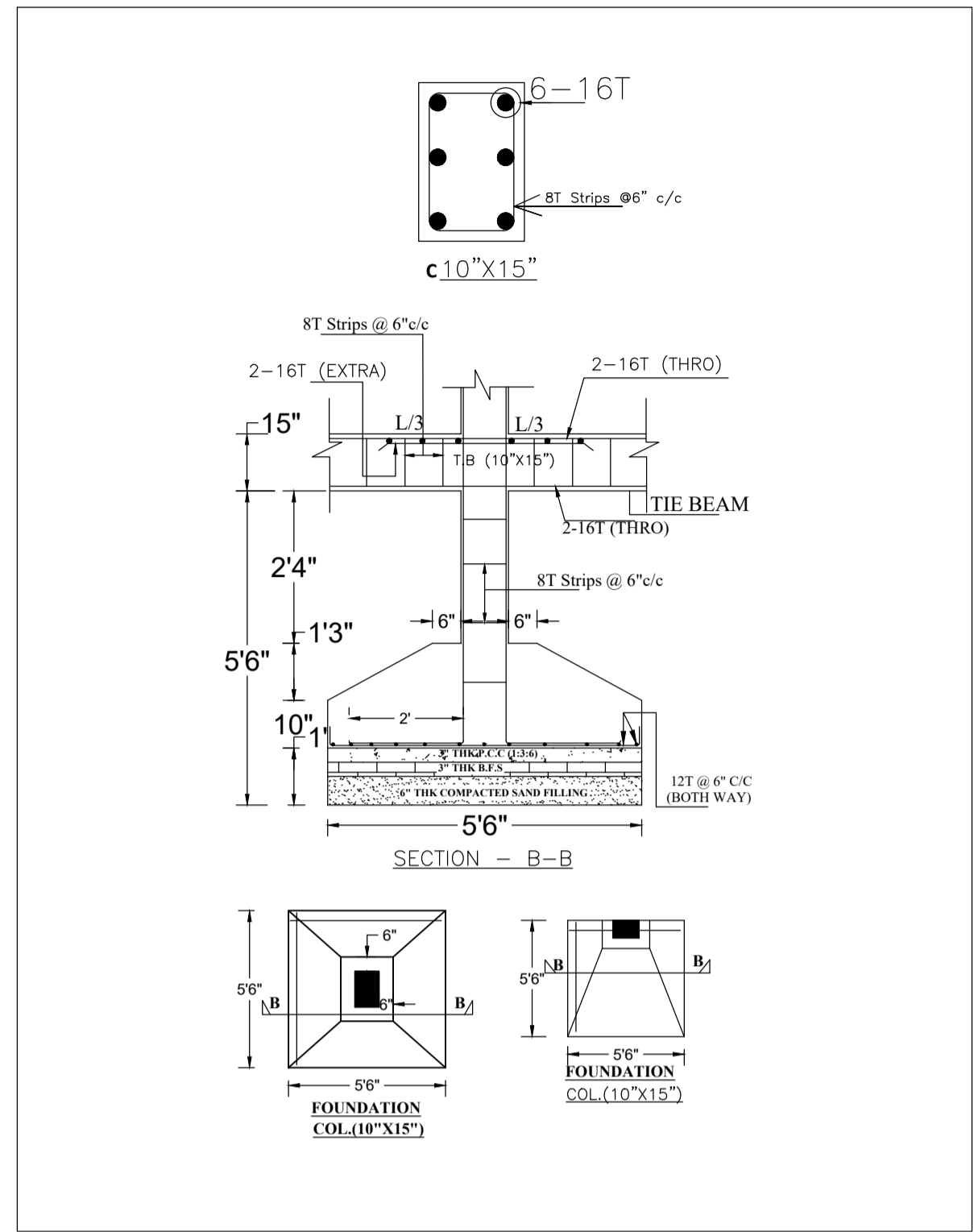

Building :AA (CC)

Floor Name	Gross Builtup Area	Deductions From Gross BUA (Area in Sq.mt.) Cutout	Total Built Up Area (Sq.mt.)	Deductions (Area in Sq.mt.)				Proposed FAR Area (Sq.mt.)	Total FAR Area (Sq.mt.)	Total Consumed Additional FAR Area (Sq.mt.)	Tnmt (No.)
				Lift	Balcony	Accessory Use	Parking				
Ground Floor	332.92	0.00	332.92	5.63	0.00	0.00	180.27	147.02	147.02	147.02	01
First Floor	337.30	4.42	332.88	0.00	0.00	3.16	0.00	329.72	329.72	329.72	01
Second Floor	366.85	4.42	362.43	5.63	13.65	3.16	0.00	339.99	339.99	339.99	01
Third Floor	366.85	4.42	362.43	5.63	13.65	3.16	0.00	339.99	339.99	339.99	01
Fourth Floor	366.85	4.42	362.43	5.63	13.65	3.16	0.00	339.99	339.99	339.99	01
Terrace Floor	0.00	0.00	0.00	0.00	0.00	0.00	0.00	0.00	0.00	0.00	00
<b>Total :</b>	<b>1770.77</b>	<b>17.68</b>	<b>1753.09</b>	<b>22.52</b>	<b>40.95</b>	<b>12.64</b>	<b>180.27</b>	<b>1496.71</b>	<b>1496.71</b>	<b>1496.71</b>	<b>05</b>
Total Number of Same Buildings :	1										
<b>Total :</b>	<b>1770.77</b>	<b>17.68</b>	<b>1753.09</b>	<b>22.52</b>	<b>40.95</b>	<b>12.64</b>	<b>180.27</b>	<b>1496.71</b>	<b>1496.71</b>	<b>1496.71</b>	<b>05</b>

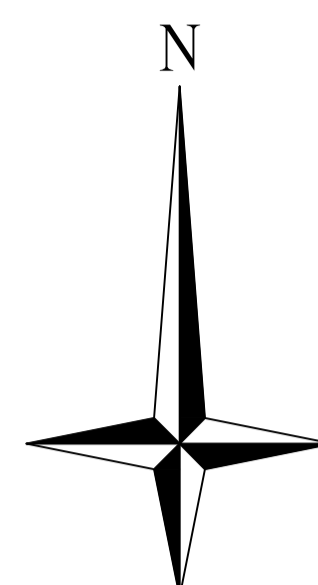

Proposal Basic Information

Proposal File No.	DGMC/BP/0107/W18/2022
Owner Name	VINA JHA
Khata No	935
Plot No	TPP No. 750
Village Name	Deoghar
Use	Residential
SubUse	Bungalow/ Dwelling / Non Apartment

SCHEDULE OF DOOR:

BUILDING NAME	NAME	LENGTH	HEIGHT	NOS
AA (CC)	D	0.77	2.10	05
AA (CC)	D	0.79	2.10	08
AA (CC)	D	0.87	2.10	01
AA (CC)	D	0.90	2.10	08
AA (CC)	D	0.91	2.10	10
AA (CC)	D	0.93	2.10	04
AA (CC)	D	0.94	2.10	04
AA (CC)	D	0.95	2.10	04
AA (CC)	D	0.97	2.10	09
AA (CC)	D	0.98	2.10	03
AA (CC)	D	0.99	2.10	08
AA (CC)	D	1.01	2.10	03
AA (CC)	D	1.02	2.10	04
AA (CC)	D	1.04	2.10	04
AA (CC)	D	1.05	2.10	03
AA (CC)	D	1.07	2.10	23
AA (CC)	D	1.08	2.10	03
AA (CC)	D	1.10	2.10	04
AA (CC)	D	1.12	2.10	05
AA (CC)	D	1.14	2.10	03
AA (CC)	D	1.15	2.10	03
AA (CC)	D	1.16	2.10	03
AA (CC)	D	1.17	2.10	03
AA (CC)	D	1.19	2.10	06
AA (CC)	D	1.20	2.10	03
AA (CC)	D	1.24	2.10	04
AA (CC)	D	1.26	2.10	04
AA (CC)	D	1.32	2.10	04
AA (CC)	D	1.37	2.10	03

SCHEDULE OF WINDOW/VENTILATION:

BUILDING NAME	NAME	LENGTH	HEIGHT	NOS
AA (CC)	V	0.72	1.20	03
AA (CC)	V	0.77	1.20	01
AA (CC)	V	0.78	1.20	03
AA (CC)	V	0.79	1.20	01
AA (CC)	V	0.81	1.20	08
AA (CC)	V	0.85	1.20	02
AA (CC)	V	0.86	1.20	04
AA (CC)	V	0.87	1.20	03
AA (CC)	V	0.91	1.20	04
AA (CC)	V	0.95	1.20	01
AA (CC)	V	1.00	1.20	03
AA (CC)	V	1.02	1.20	03
AA (CC)	V	1.03	1.20	03
AA (CC)	V	1.04	1.20	04
AA (CC)	W	1.05	1.20	03
AA (CC)	V	1.10	1.20	02
AA (CC)	V	1.13	1.20	03
AA (CC)	W	1.19	1.20	04
AA (CC)	W	1.33	1.20	01
AA (CC)	V	1.35	1.20	01
AA (CC)	W	1.40	1.20	05
AA (CC)	W	1.47	1.20	03
AA (CC)	W	1.52	1.20	01
AA (CC)	W	1.58	1.20	03
AA (CC)	W	1.60	1.20	03
AA (CC)	W	1.66	1.20	01
AA (CC)	W	1.67	1.20	01
AA (CC)	W	1.73	1.20	03
AA (CC)	W	1.76	1.20	03
AA (CC)	W	1.86	1.20	03
AA (CC)	W	1.87	1.20	03
AA (CC)	W	1.89	1.20	02
AA (CC)	W	1.93	1.20	03
AA (CC)	W	2.00	1.20	01
AA (CC)	W	2.01	1.20	05
AA (CC)	W	2.03	1.20	03
AA (CC)	W	2.08	1.20	04
AA (CC)	W	2.09	1.20	03
AA (CC)	W	2.10	1.20	04
AA (CC)	W	2.12	1.20	01
AA (CC)	W	2.13	1.20	03
AA (CC)	W	2.27	1.20	03
AA (CC)	W	2.31	1.20	04
AA (CC)	W	2.36	1.20	01
AA (CC)	W	2.41	1.20	04
AA (CC)	W	2.45	1.20	01
AA (CC)	W	2.54	1.20	03
AA (CC)	W	2.66	1.20	03
AA (CC)	W	2.95	1.20	01
AA (CC)	W	3.44	1.20	01
AA (CC)	W	3.81	1.20	01
AA (CC)	W	7.38	1.20	01

UnitBUA Table for Building :AA (CC)

FLOOR	Name	UnitBUA Type	UnitBUA Area	Carpet Area	No. of Rooms	No. of Tenement
GROUND FLOOR PLAN	A	FLAT	147.02	146.96	5	1
FIRST FLOOR PLAN	B	FLAT	327.25	325.82	31	1
TYPICAL - 2, 3, 4 FLOOR PLAN	C	FLAT	356.80	328.04	31	3
<b>Total:</b>	-	-	<b>1544.66</b>	<b>1456.91</b>	<b>129</b>	<b>5</b>

Balcony Calculations Table

FLOOR	SIZE	AREA	TOTAL AREA
TYPICAL - 2, 3, 4 FLOOR PLAN	0.84 X 6.25 X 1 X 3	15.69	81.93
	0.84 X 2.11 X 1 X 3	5.31	
	0.84 X 3.48 X 1 X 3	8.73	
	0.84 X 3.53 X 1 X 3	8.88	
	0.84 X 6.65 X 1 X 3	16.35	
	0.87 X 4.18 X 1 X 3	10.92	
	0.84 X 2.93 X 1 X 3	7.35	
	0.87 X 3.33 X 1 X 3	8.70	
<b>Total</b>	-	-	<b>81.93</b>

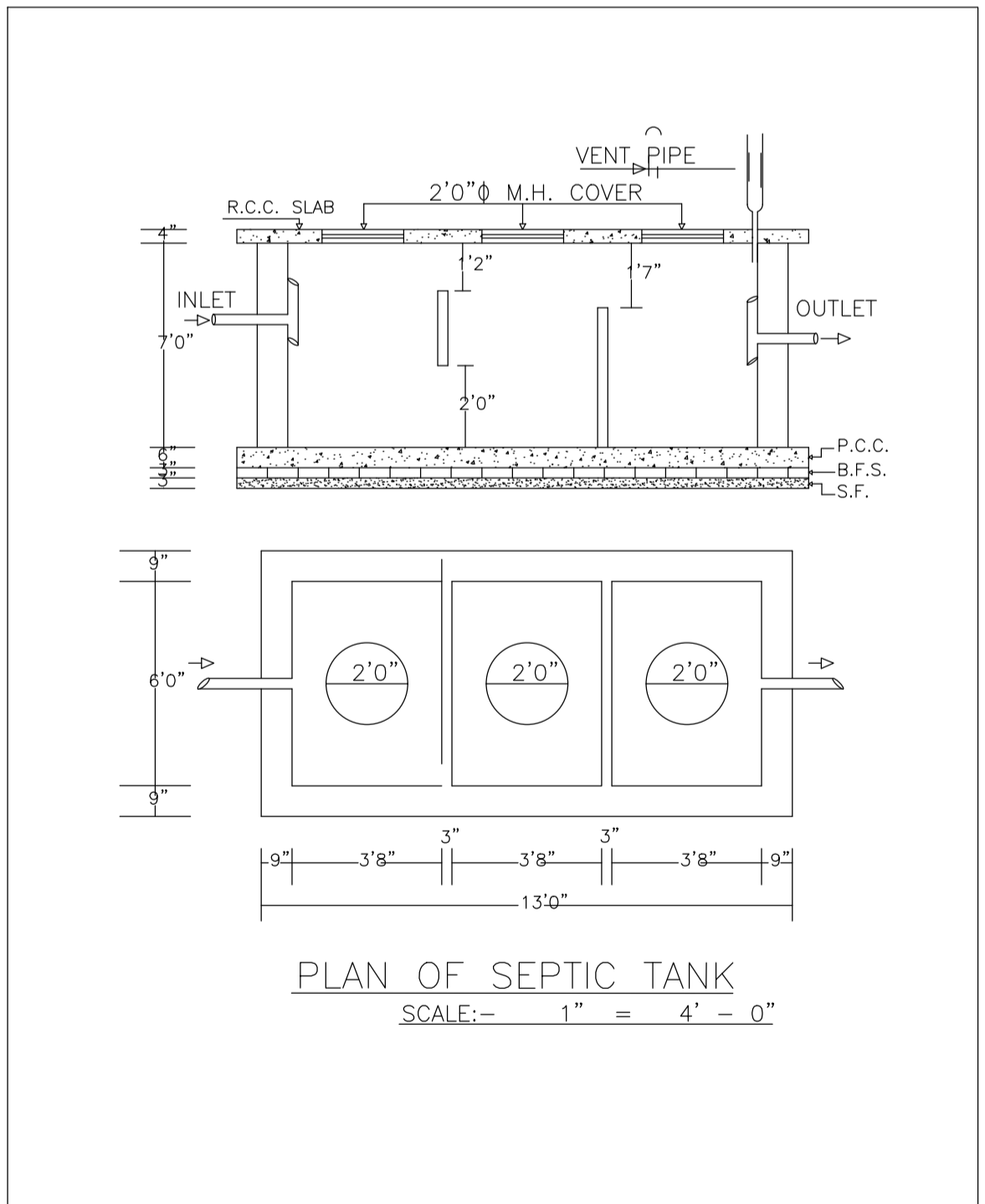
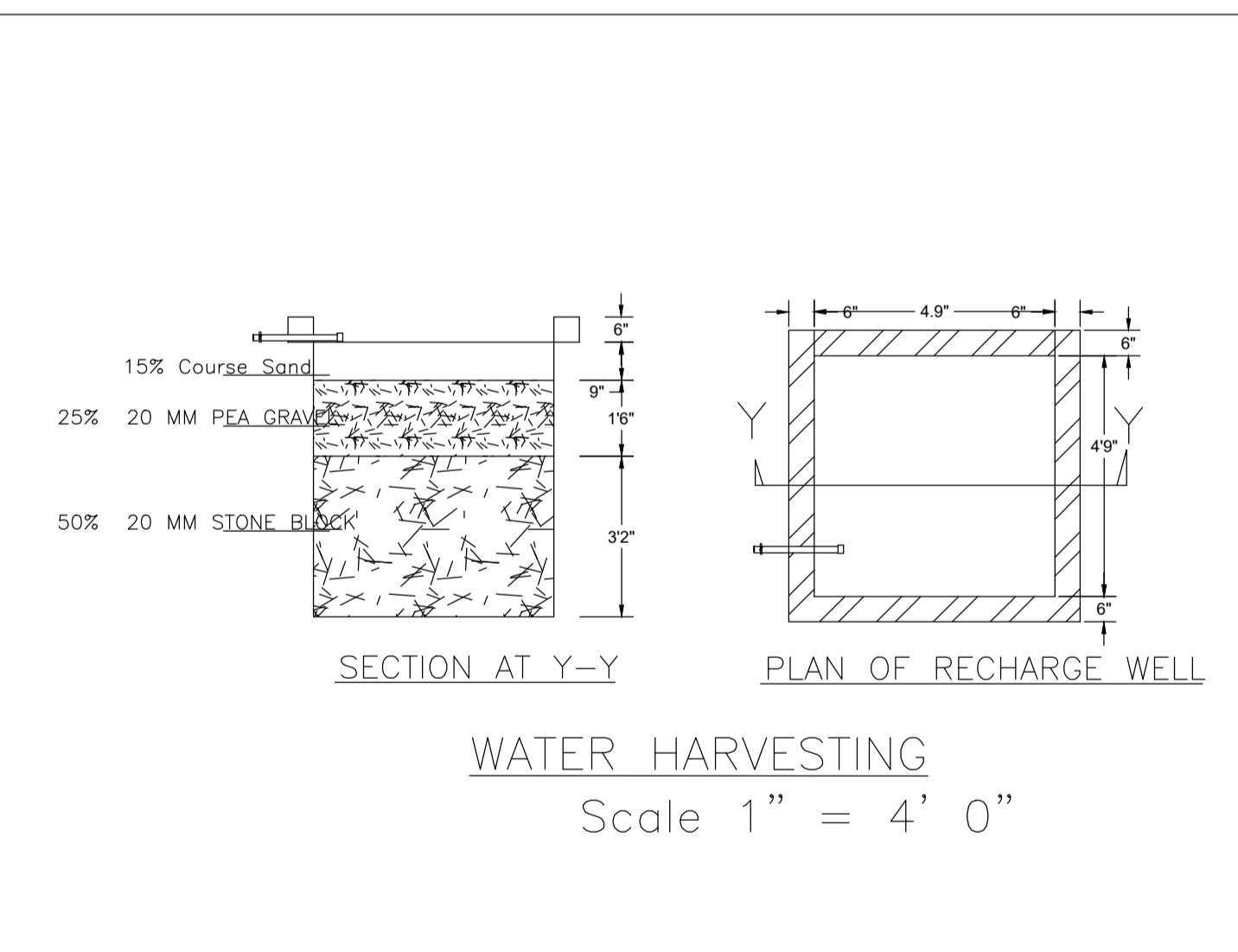

LTP NAME AND SIGNATURE	STRUCTURAL ENG'S NAME AND SIGNATURE	BUILDER NAME AND SIGNATURE	DIGITAL SIGNATURE
SIDHARTH DGMC/ARC/0002/2016			