



FRONT SET BACK:-8'-6"
REAR SET BACK:-5'-0"
RIGHT SET BACK:-3'-0"
LEFT SET BACK:-NIL

N:-LAND OF SARITA KUMARI & VARSHA KUMARI
S:-VENDOR'S LAND.
E:-10'-0" WIDE PROPOSED ROAD.
W:-LAND OF MEENA DEVI & PUJA KUMARI.

SCHEDULE OF DOOR & WINDOW

DOOR	WIDTH	LINTEL	SILL LVL.	SIZE
D	3'6"	7'0"	+00	3'6"X7'0"
D1	3'0"	7'0"	+00	3'0"X7'0"
D2	2'6"	7'0"	+00	2'6"X7'0"

WINDOW	WIDTH	LINTEL	SILL LVL.	SIZE
W	5'0"	4'6"	2'6"	5'0"X4'6"
W1	3'0"	4'6"	2'6"	3'0"X4'6"
V	2'6"	1'6"	5'6"	2'6"X1'6"

AREA STATEMENT

AREA OF LAND(as per deed) :- 1209.0 SFT.
 AREA OF LAND :- 1207.0 SFT.

PARKING AREA :- 205.0 SFT.

G.F BUILT UP AREA(R) :- 696.0SFT

F.F BUILT UP AREA(R) :- 696.0SFT

G.F. COVERAGE AREA:- 57.66%

F.A.R. :- 0.98

TOTAL BUILDING HIGHT :- 18'10"

PLAN ELEVATION AND DETAILS DRAWING OF A RESIDENTIAL BUILDING BY UNDER MOUZA:-SALONATARN NO:-253. WARD NO:-15. J. B. NO:-64. PART OF T. P. PLOT NO:-284. HOLDING NO:-0150001260000M0 UNDER DEOGHAR NAGAR NIGAM

OWNER SING. **SING. OF ENGG.**

CONSULTANTS:- SHIV CONSTRUCTION
 OFFICE:- INFRONT OF SRIRAM JANKI MANDIR DEOGHAR (JHARKHAND)

SCALE:- 1: 100

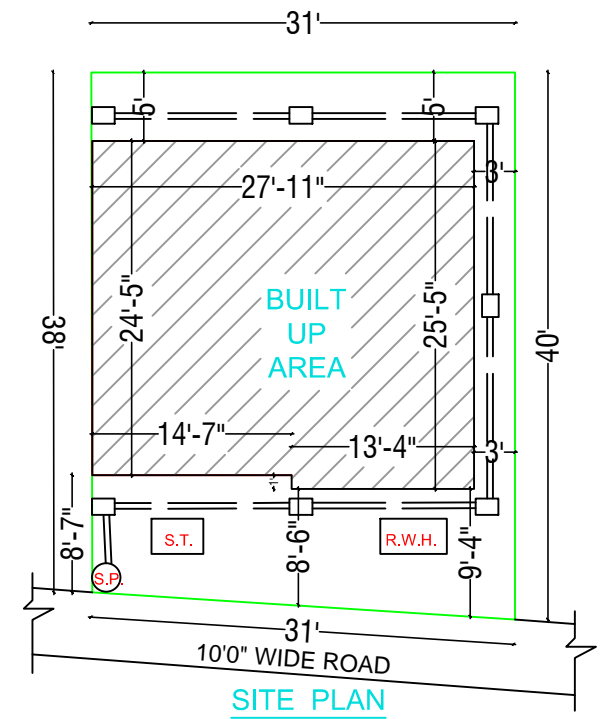
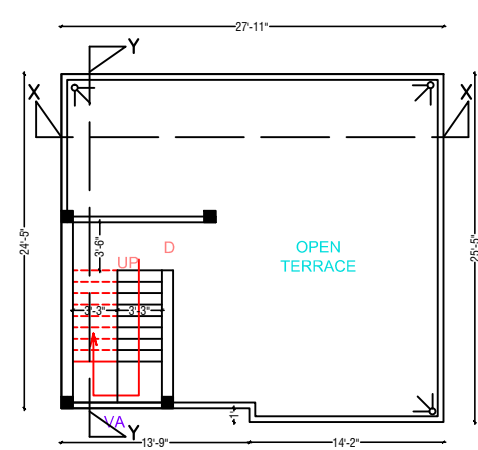
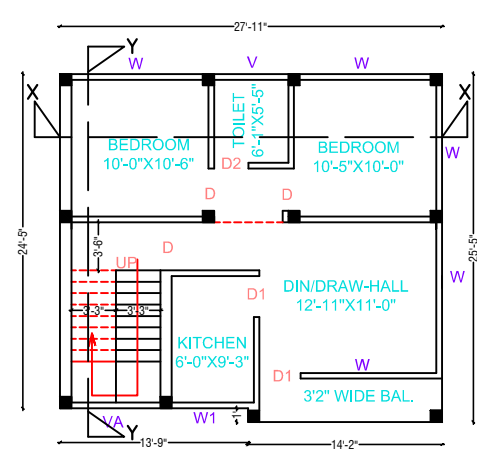
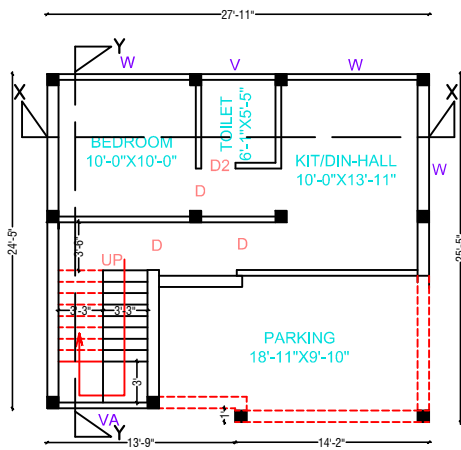
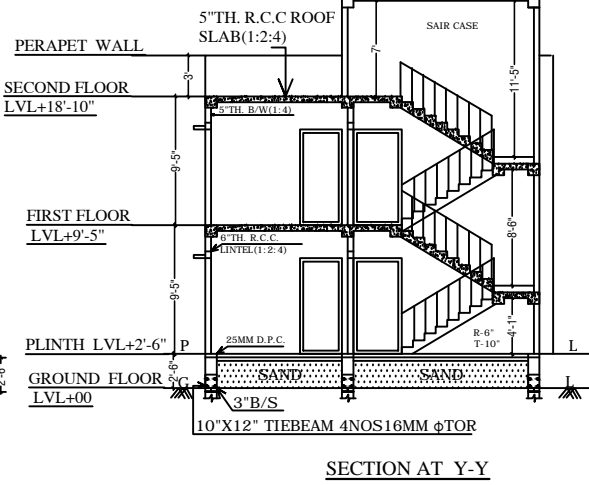
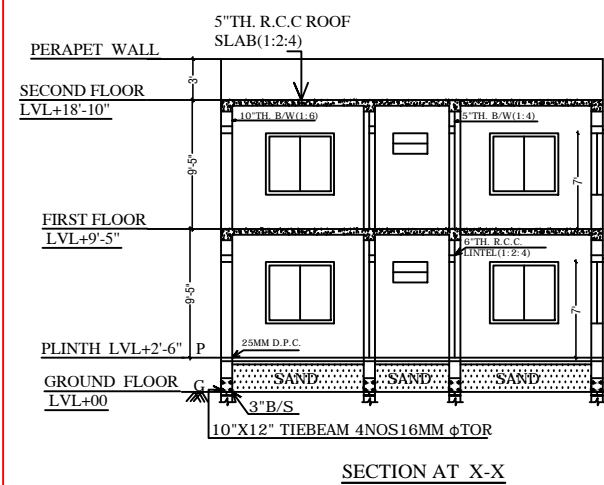
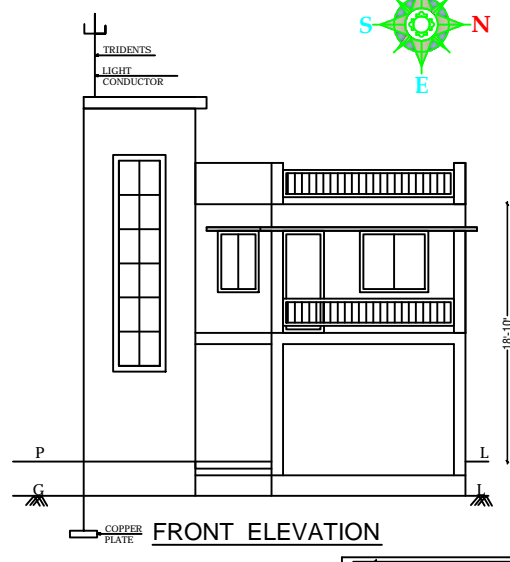
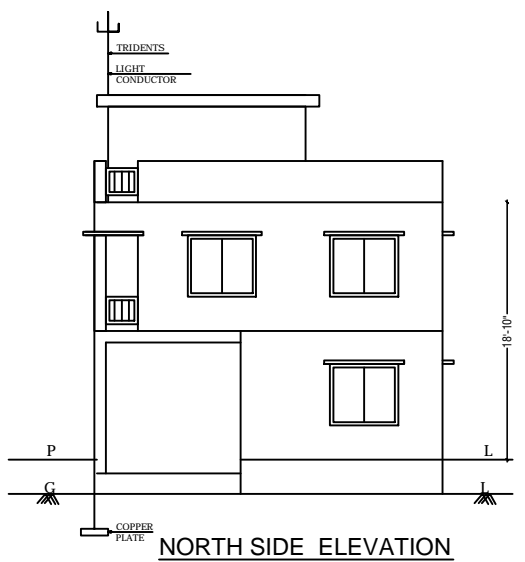
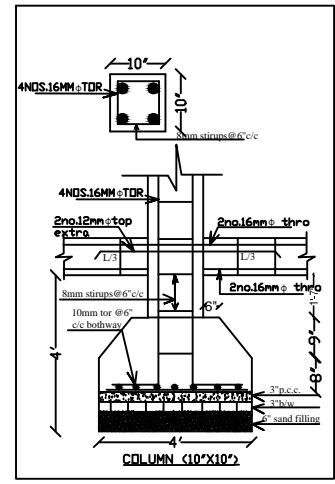
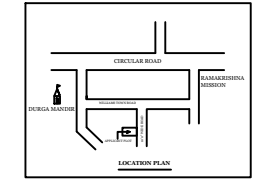
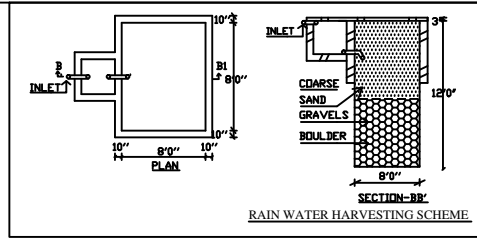
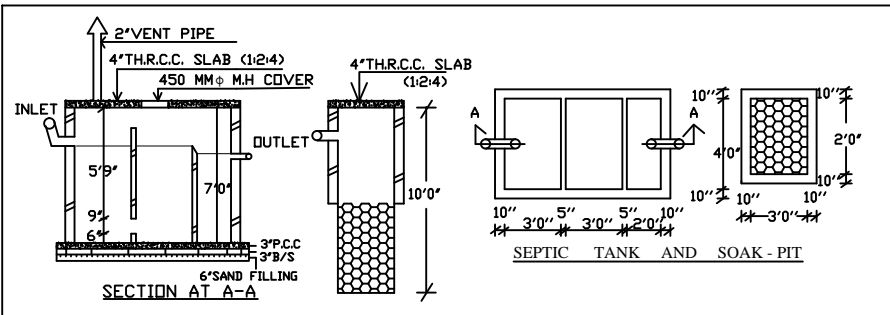

GROUND FLOOR PLAN

FIRST FLOOR PLAN

TERRACE PLAN

SITE PLAN