

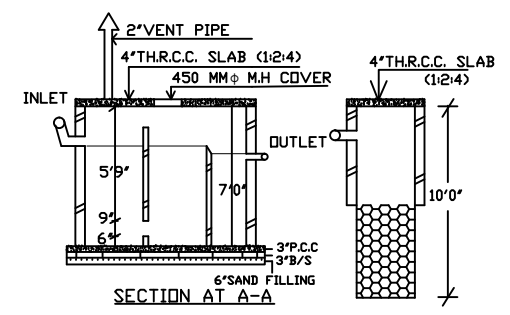

EAST SIDE ELEVATION

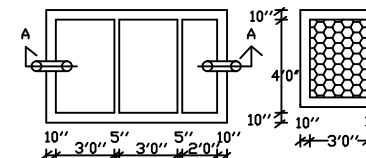

SECTION AT A-A



SEPTIC TANK AND SOAK - PIT

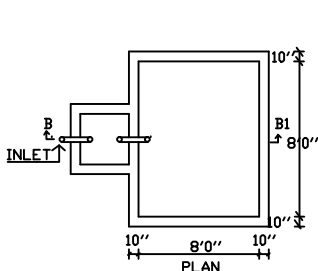

RAIN WATER HARVESTING SCHEME

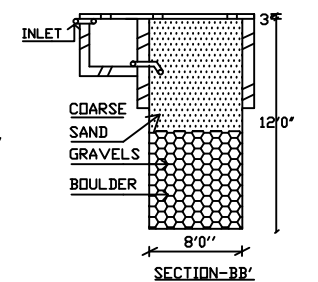

SECTION-BB'

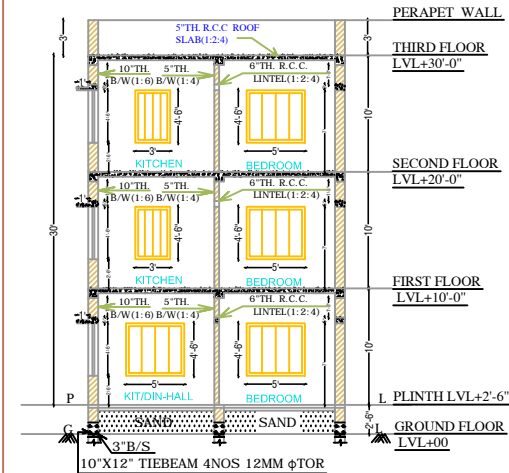
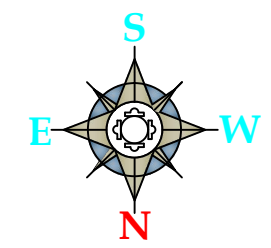

SECTION AT X-X

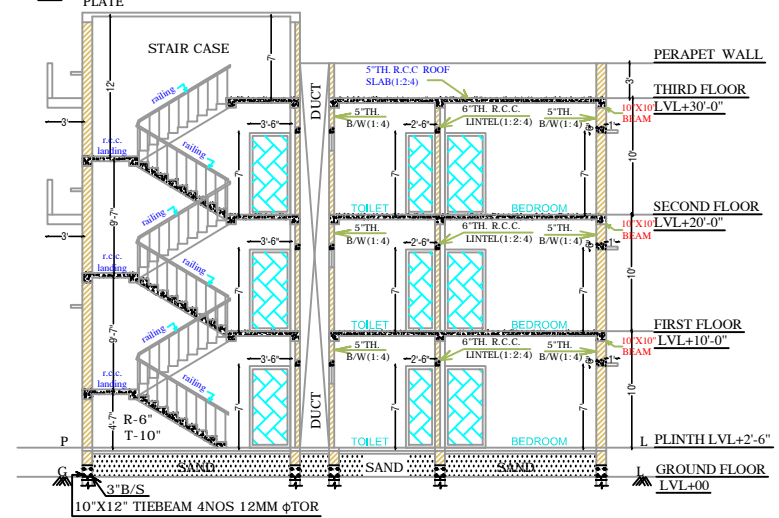

SECTION AT Y-Y

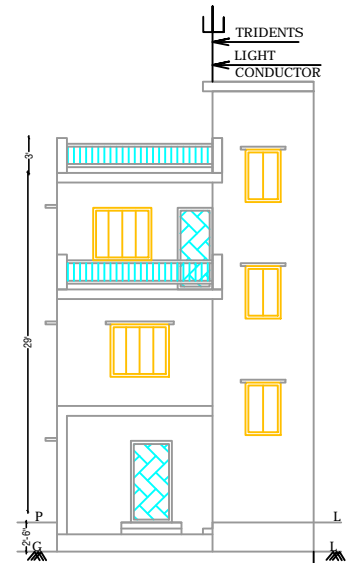

FRONT ELEVATION

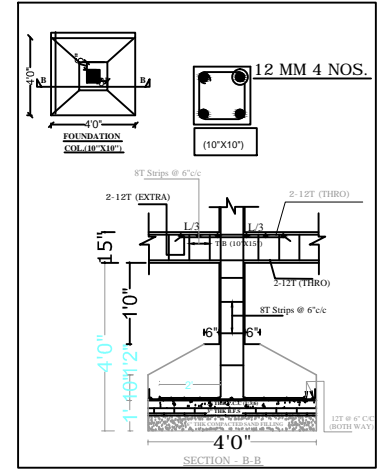

SECTION - B-B

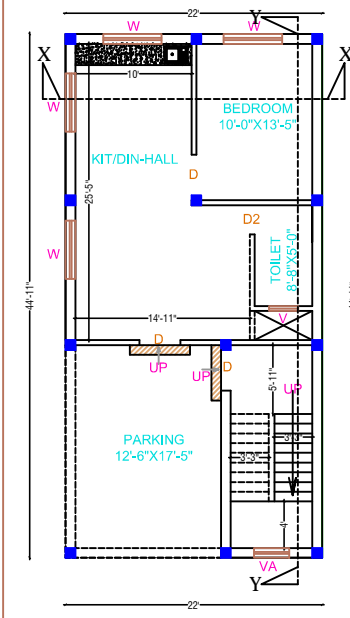

GROUND FLOOR PLAN

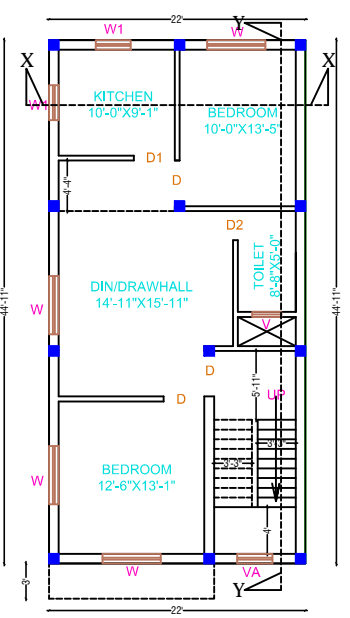

FIRST FLOOR PLAN

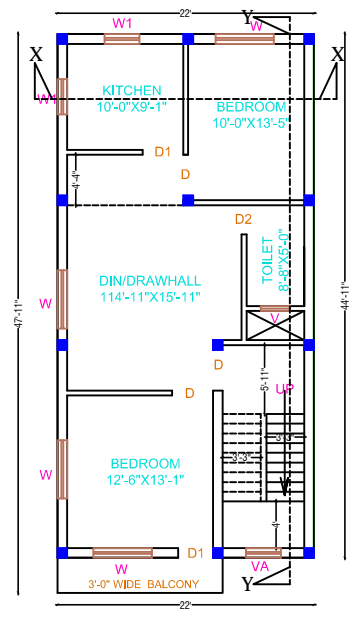

SECOND FLOOR PLAN

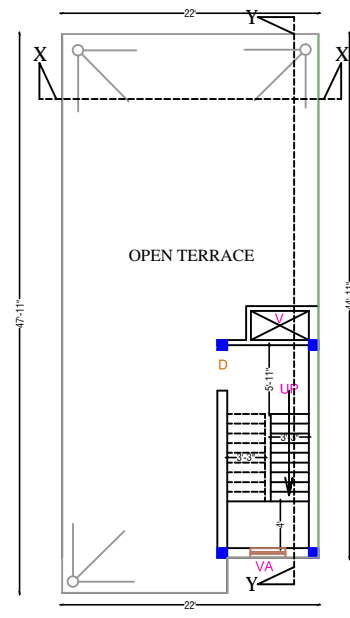

TERRACE PLAN

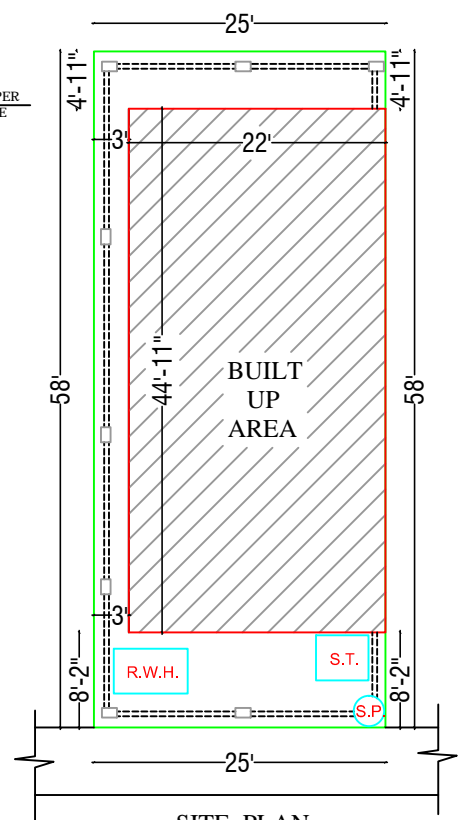

SITE PLAN

N:-25'0" WIDE ROAD
 S:-SUB PLOT NO.- 9 & 10
 E:-SUB PLOT NO.- 6 & 7
 W:-SUB PLOT NO.- 5

FRONT SET BACK:-8'-2"
 REAR SET BACK:-4'-11"
 RIGHT SET BACK:-NIL
 LEFT SET BACK:-3'-0"

SCHEDULE OF DOOR & WINDOW

DOOR	WIDTH	LINTEL	SILL LVL.	SIZE
D	3'6"	7'0"	+00	3'6"X7'0"
D1	3'0"	7'0"	+00	3'0"X7'0"
D2	2'6"	7'0"	+00	2'6"X7'0"
WINDOW	WIDTH	LINTEL	SILL LVL.	SIZE
W	5'0"	4'6"	2'6"	5'0"X4'6"
W1	3'0"	4'6"	2'6"	3'0"X4'6"
V	2'6"	1'6"	5'6"	2'6"X1'6"

AREA STATEMENT

AREA OF LAND (as per deed):- 1450.0SFT
 AREA OF LAND :- 1450.0SFT

PARKING AREA :- 243.0SFT
 DUCT AREA :- 12.0SFT
 50% BALCONY AREA :- 42.0SFT

GROUND FLOOR BUILT UP AREA(R):- 988.0SFT
 FIRST FLOOR BUILT UP AREA(R) :- 988.0SFT
 SECOND FLOOR BUILT UP AREA(R) :- 988.0SFT

FOR F.A.R.:-
 GROUND FLOOR BUILT UP AREA :-733.0SFT
 FIRST FLOOR BUILT UP AREA :-976.0SFT
 SECOND FLOOR BUILT UP AREA(R) :- 934.0SFT
 F.A.R. :- 1.8 TOAL :- 2643.0SFT

G.F. COVERAGE AREA :- 68.13%
 TOTAL BUILDING HEIGHT :- 30'-0"

PLAN ELEVATION & DETAILS DRAWING OF A RESIDENTIAL BUILDING BY SRI DEEPAK KUMAR S/O RADHESHYAM BURNWAL. MOUZA:-BARMASIA NO:-254. J.B.NO.:-7/2869. WARD NO.:-14 T.P. PLOT NO.:-357. PART FO PLOT NO.:-516 SUB PLOT NO.:-5PART & 6PART HOLDING NO.:-0140001535000MO . UNDER DEOGHAR NAGAR NIGAM(JHARKHAND).

OWNER SIGN. _____ SIGN. OF ENGG. _____
 CONSULTANTS- SHIV CONSTRUCTION
 OFFICE:- INFRONT OF SRIRAM JANKI MANDIR
 DEOGHAR (JHARKHAND)
 SCALE:-1:100