

RAIN WATER HARVESTING SCHEME

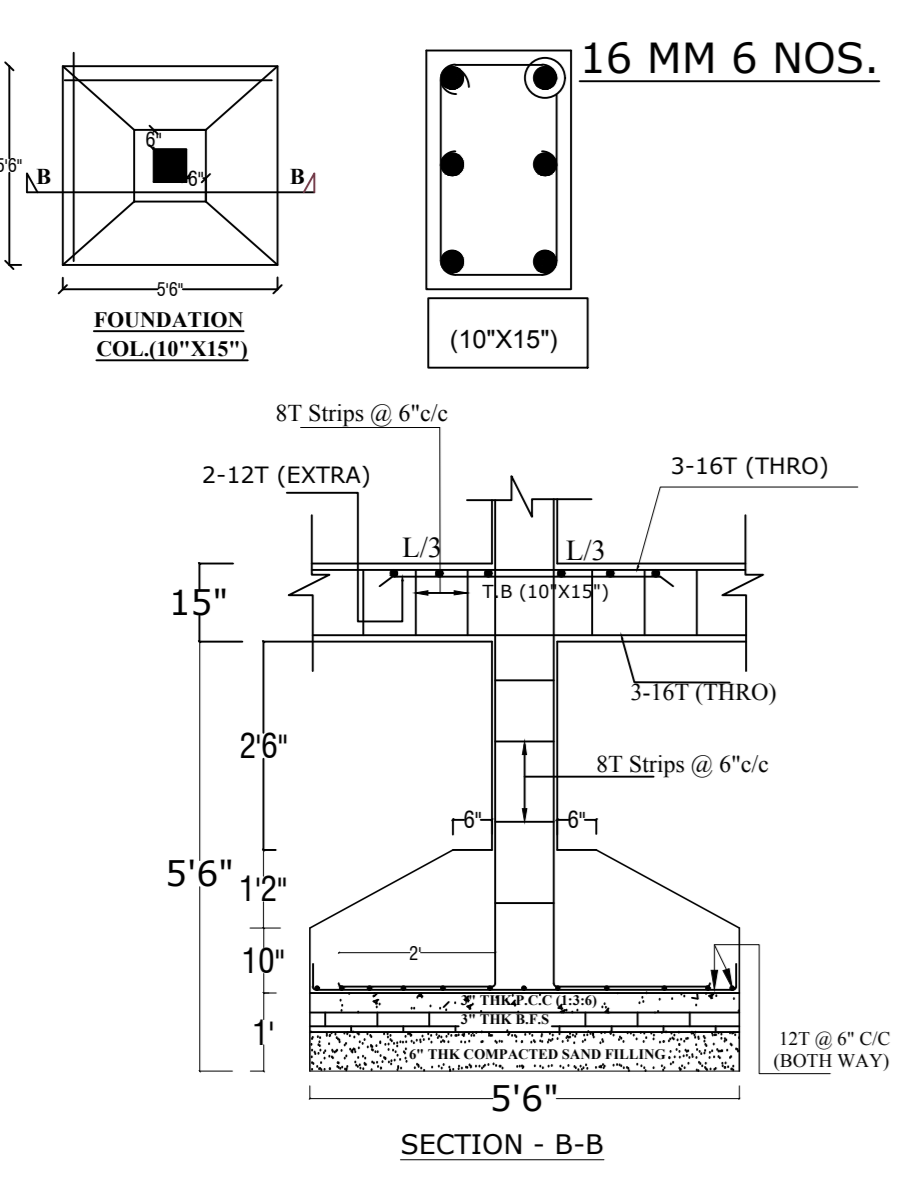

Proposal Basic Information	
Proposal File No.	DMC/CP/04/9/32/2023
Owner Name	SMT PUNAM SINGH
Khata No.	54/3217 55/3212 256/365A/1
Plot No.	776
Village Name	Deoghar
Use	Residential
SubUse	Bungalow Dwelling / Non Apartment
AREA STATEMENT	VERSION NO. 1.0.66
DEOGHAR MUNICIPAL CORPORATION	VERSION DATE: 16/10/2020
PROJECT DETAIL:	
Region: JHARKHAND URBAN LOCAL BODIES	Plot Use: Residential
District: DEOGHAR	Plot SubUse: Bungalow/ Dwelling / Non Apartment
Authority: DEOGHAR MUNICIPAL CORPORATION	PlotNearby/Religious/Structure: NA
Project No: DM/CP/04/9/32/2023	Plot/Plot No: 776
Application Type: General Proposal	North: Plot No. -VENDOR LAND AND SUR PLOT NO 15
Project Type: Building Permission	South: Road Width - 4.57 M WIDE PROPOSED ROAD
Nature of Development: New	East: Road Width - 4.57 M WIDE PROPOSED ROAD
Location of Development Area: Old Area	West: Plot No. - LAND OF MANJU BARNWAL AND OTHERS
AREA DETAILS:	
AREA OF PLOT (Minimum)	(A)
NET AREA OF PLOT(Gross Plot Area - Deduction from Gross Plot Area)	(A-Deductions)
Deduction for Balance Plot Area(from Gross Plot Area)	
Common Plot	9.36
Total	9.36
BALANCE AREA OF PLOT(Net Plot Area - Recreational/Amenity)	(A-Deductions)
PLOT AREA FOR COVERAGE(Net Plot Area)	(A-Deductions)
Plot Area for FAR (Net Plot Area - Road/Widening Area)	(A-Deductions)
COVERAGE CHECK	
Permissible Coverage area (70.00 %)	106.05
Proposed Coverage Area (57.39 %)	86.94
Total Prop. Coverage Area (57.39 %)	86.94
Balance coverage area (12.61 %)	19.11
FAR CHECK	
Perm. FAR Area (1.500)	227.25
Total Perm. FAR Area	227.25
Residential FAR	210.60
Proposed FAR Area	219.58
Total Proposed FAR Area	219.58
Consumed FAR (Factor)	1.45
Balance FAR Area	7.67
BUILT UP AREA CHECK	
Total Proposed BuiltUp Area	263.75
ARCHITECT (Regd)	ALOK KUMAR SINGH
ENGINEER (Regd)	
SUPERVISOR (Regd)	
OWNER (Regd)	SMT PUNAM SINGH
DEVELOPMENT AUTHORITY	LOCAL BODY

COLOR INDEX	
PLOT BOUNDARY	Black
ABUTTING ROAD	Green
PROPOSED CONSTRUCTION	Red
COMMON PLOT	Yellow
ROAD WIDENING AREA	Blue
EXISTING (To be retained)	Orange
EXISTING (To be demolished)	Grey

Buildingwise Floor FAR Details				
Floor Name	Building Name		Total	
	Proposed Built Up Area (Sq.mt.)	Proposed FAR Area (Sq.mt.)	Total Proposed Built Up Area (Sq.mt.)	Total FAR Area (Sq.mt.)
Ground Floor	86.94	44.23	86.94	44.23
First Floor	86.94	86.94	86.94	86.94
Second Floor	89.87	88.41	89.87	88.41
Terrace Floor	0.00	0.00	0.00	0.00
Total	263.75	219.58	263.75	219.58

Building USE/SUBUSE Details			
Building Name	Building Use	Building SubUse	Building Structure
A (SMT PUNAM SINGH)	Residential	Bungalow Dwelling / Non Apartment	Non-Highrise

FAR & Tenement Details (Table 4c-1)									
Building	No. of Same Bldg	Total Built Up Area (Sq.mt.)	Deductions (Area in Sq.mt.)		Proposed FAR Area (Sq.mt.)	Total FAR Area (Sq.mt.)	Total Consumed FAR Area (Sq.mt.)	Trtmt (No.)	
			Balcony	Parking					
A (SMT PUNAM SINGH)	1	263.75	1.46	42.71	210.60	8.98	219.58	219.58	01
Grand Total	1	263.75	1.46	42.71	210.60	8.98	219.58	219.58	01

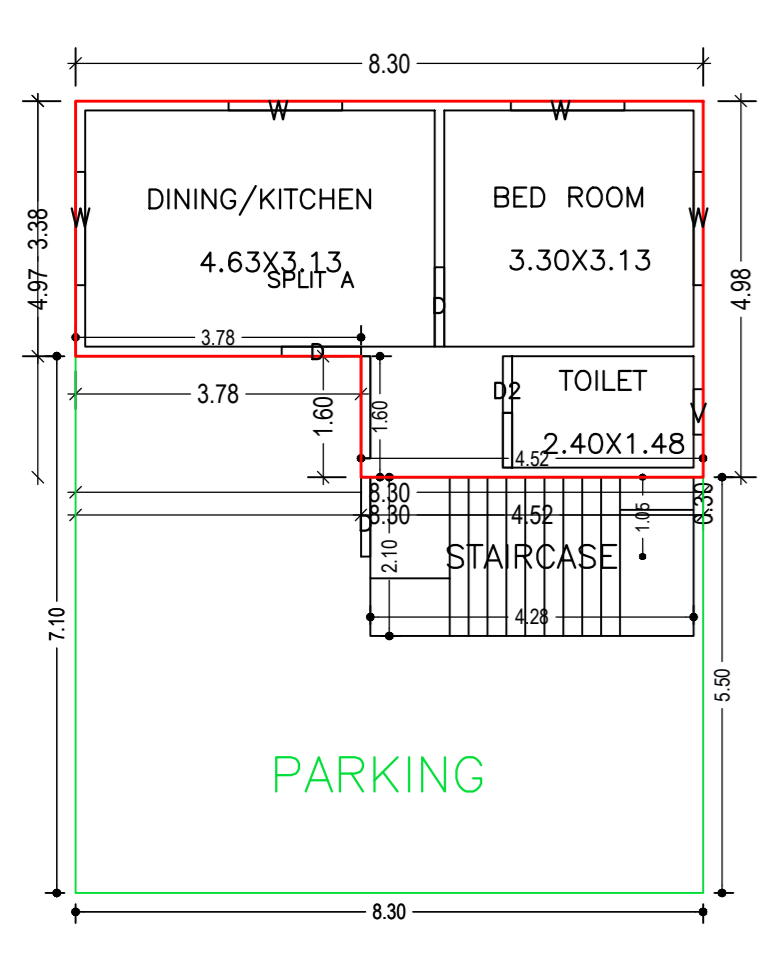

GROUND FLOOR PLAN (Proposed) (SCALE 1:100)

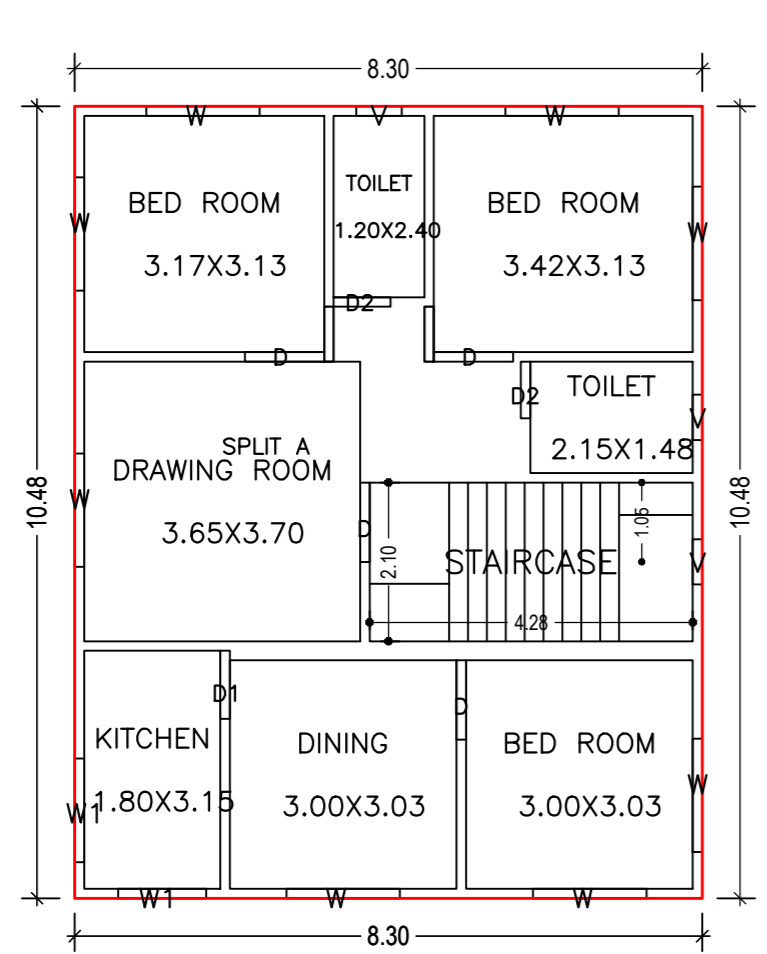

FIRST FLOOR PLAN (Proposed) (SCALE 1:100)

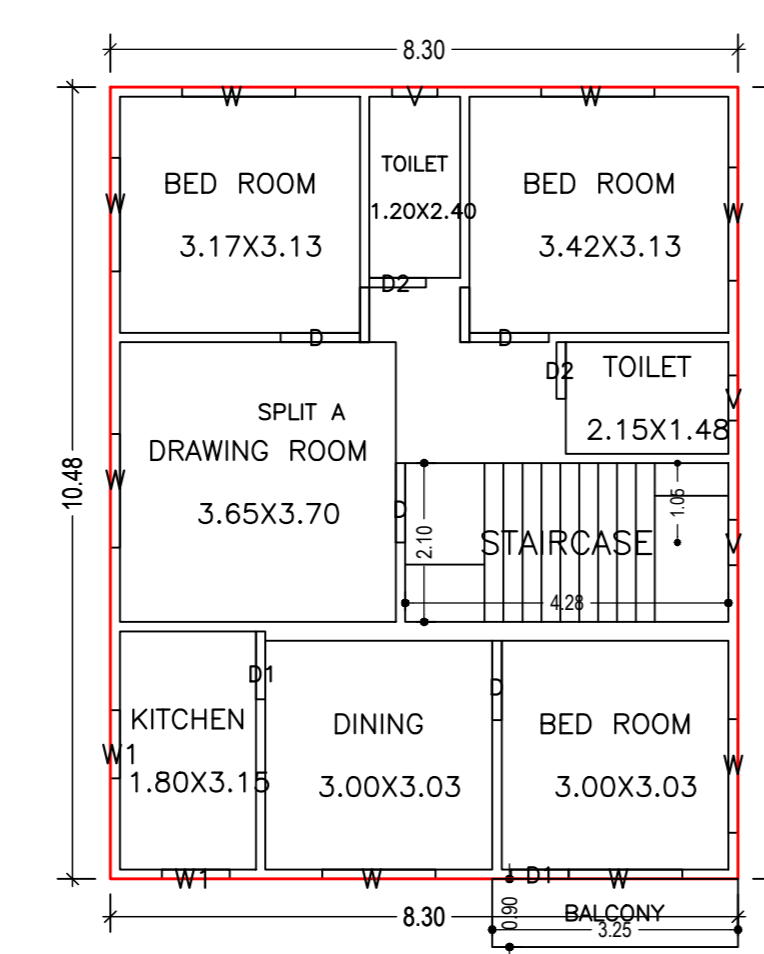

SECOND FLOOR PLAN (Proposed) (SCALE 1:100)

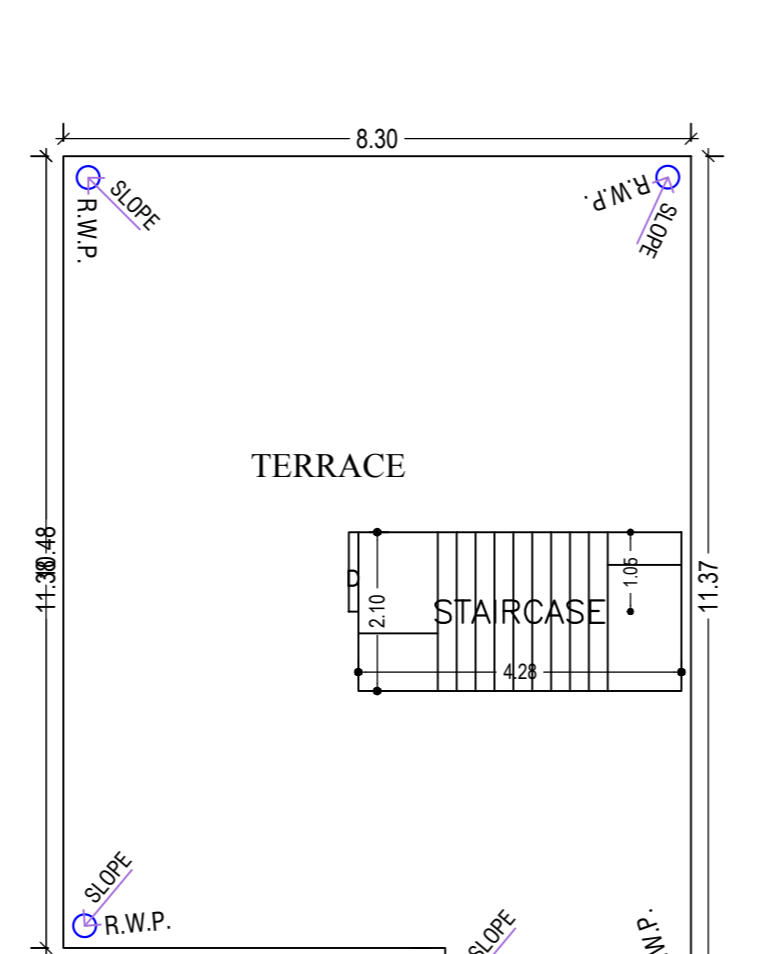

TERRACE FLOOR PLAN (Proposed) (SCALE 1:100)

Building :A (SMT PUNAM SINGH)								
Floor Name	Total Built Up Area (Sq.mt.)	Deductions (Area in Sq.mt.)		Proposed FAR Area (Sq.mt.)	Add Area in FAR (Sq.mt.)	Total FAR Area (Sq.mt.)	Total Consumed Additional FAR Area (Sq.mt.)	Trtmt (No.)
		Balcony	Parking					
Ground Floor	86.94	0.00	42.71	35.25	8.98	44.23	44.23	01
First Floor	86.94	0.00	0.00	86.94	0.00	86.94	86.94	00
Second Floor	89.87	1.46	0.00	88.41	0.00	88.41	88.41	00
Terrace Floor	0.00	0.00	0.00	0.00	0.00	0.00	0.00	00
Total	263.75	1.46	42.71	210.60	8.98	219.58	219.58	01
Total Number of Same Buildings	1							
Total	263.75	1.46	42.71	210.60	8.98	219.58	219.58	01

SCHEDULE OF DOOR:				
BUILDING NAME	NAME	LENGTH	HEIGHT	NOS
A (SMT PUNAM SINGH)	D2	0.75	2.13	05
A (SMT PUNAM SINGH)	D1	0.76	2.13	01
A (SMT PUNAM SINGH)	D1	0.90	2.13	02
A (SMT PUNAM SINGH)	D	1.05	2.13	10

SCHEDULE OF WINDOW/VENTILATION:				
BUILDING NAME	NAME	LENGTH	HEIGHT	NOS
A (SMT PUNAM SINGH)	V	0.60	1.20	07
A (SMT PUNAM SINGH)	W1	0.90	1.20	02
A (SMT PUNAM SINGH)	W1	1.16	1.20	01
A (SMT PUNAM SINGH)	W1	1.37	1.20	01
A (SMT PUNAM SINGH)	W	1.50	1.20	20

UnitBUA Table for Building :A (SMT PUNAM SINGH)						
FLOOR	Name	UnitBUA Type	UnitBUA Area	Carpet Area	No. of Rooms	No. of Tenement
GROUND FLOOR PLAN	SPLIT A	FLAT	197.63	197.17	3	1
FIRST FLOOR PLAN	SPLIT A	FLAT	0.00	0.00	8	0
SECOND FLOOR PLAN	SPLIT A	FLAT	0.00	0.00	8	0
Terrace Floor	-	-	197.63	197.17	19	1

Balcony Calculations Table			
FLOOR	SIZE	AREA	TOTAL AREA
SECOND FLOOR PLAN	0.90 X 3.25 X 1 X 1	2.93	2.93
Total	-	-	2.93

LTP NAME AND SIGNATURE	STRUCTURAL ENG'S NAME AND SIGNATURE	BUILDER NAME AND SIGNATURE	DIGITAL SIGNATURE
ALOK KUMAR SINGH DMC/ENG0007/2017			