

SITE PLAN

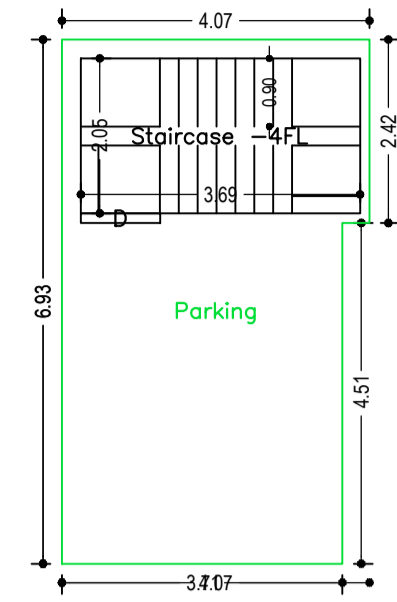

GROUND FLOOR PLAN (SCALE 1:100)

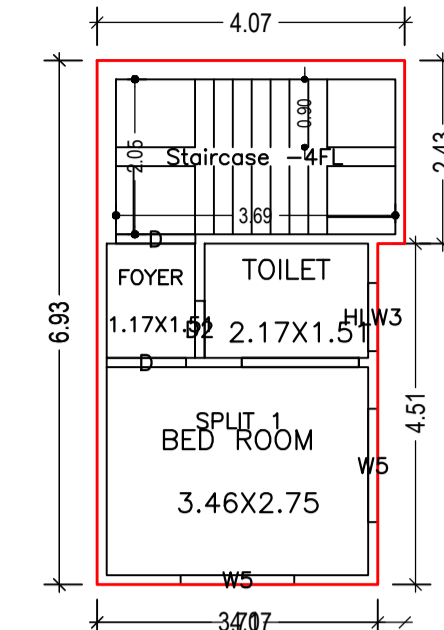

FIRST FLOOR PLAN (Proposed) (SCALE 1:100)

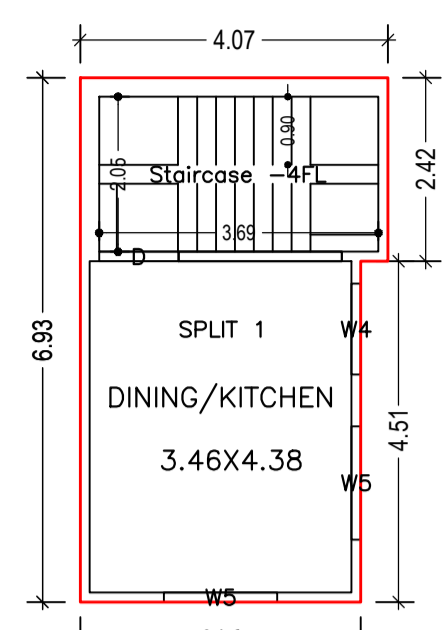

SECOND FLOOR PLAN (Proposed) (SCALE 1:100)

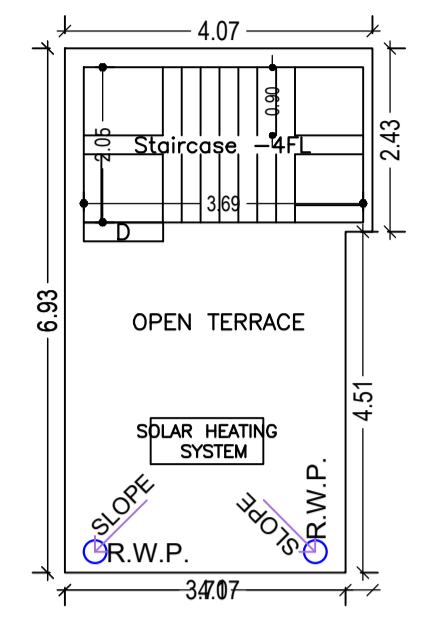

TERRACE FLOOR PLAN (SCALE 1:100)

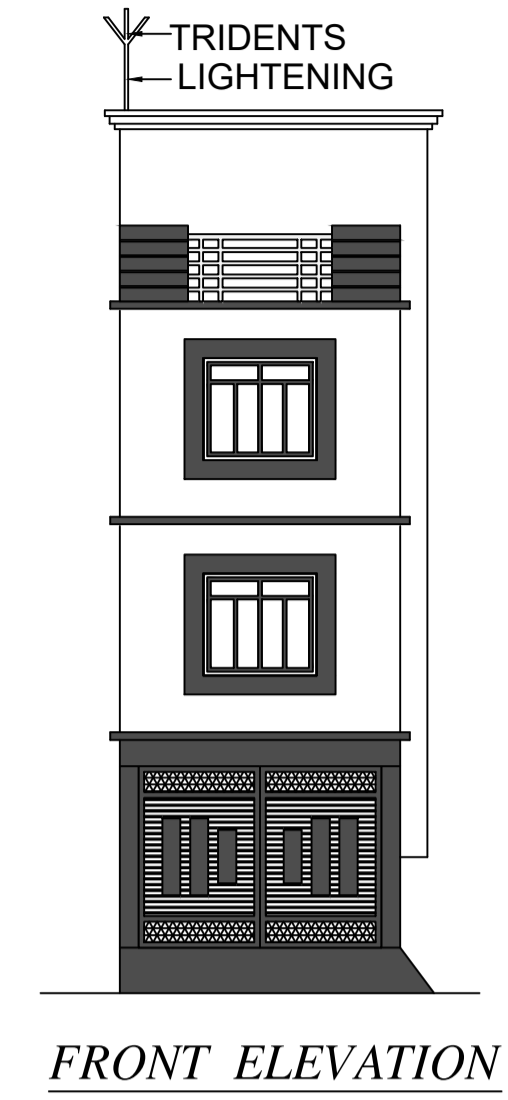

FRONT ELEVATION

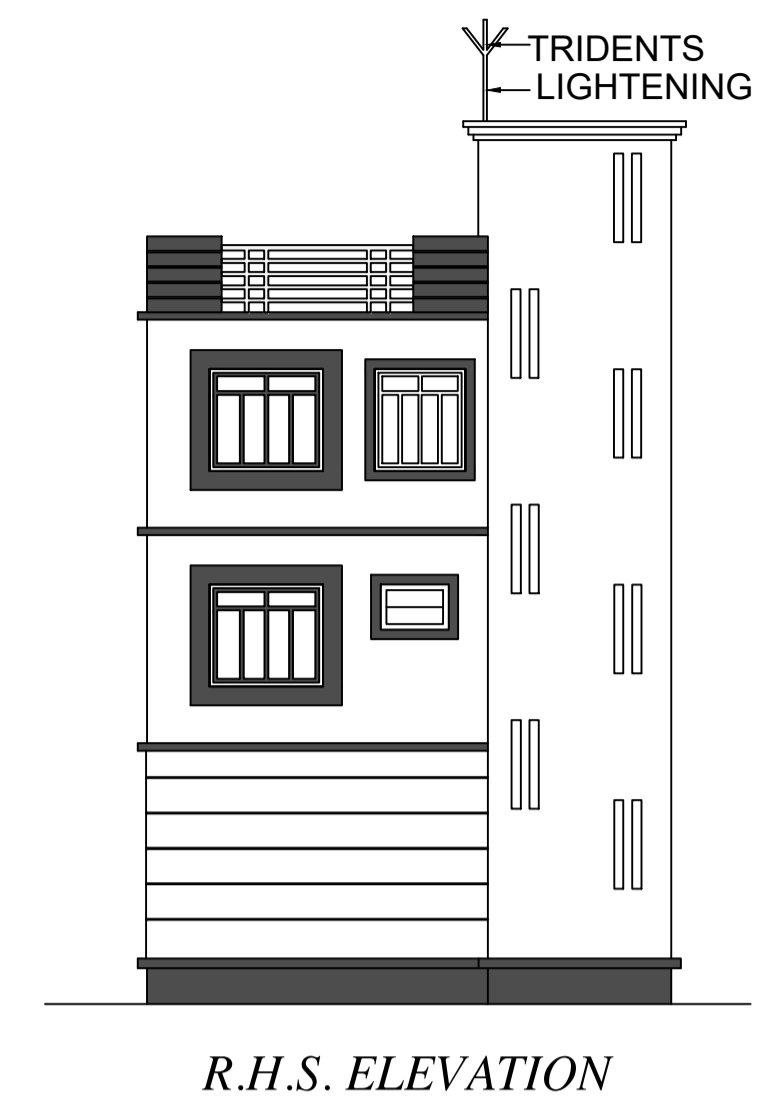

R.H.S. ELEVATION

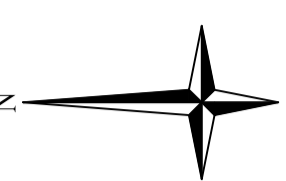

Proposal Basic Information	
Proposal File No.	DGMC/BP/0098/W30/2023
Owner Name	MANJU DEVI
Khata No	1454/3/2
Plot No	TPP NO.- 524
Village Name	Deoghar
Use	Residential
SubUse	Bungalow/ Dwelling / Non Apartment

AREA STATEMENT		VERSION NO. : 1.0.66
DEOGHAR MUNICIPAL CORPORATION		VERSION DATE: 16/10/2020
PROJECT DETAIL:		
Region: JHARKHAND URBAN LOCAL BODIES	Plot Use: Residential	
District: DEOGHAR	Plot SubUse: Bungalow/ Dwelling / Non Apartment	
Authority: DEOGHAR MUNICIPAL CORPORATION	PlotNearbyReligiousStructure: NA	
Inward No: DGMC/BP/0098/W30/2023	Plot/SubPlot No: TPP NO.- 524	
Application Type: General Proposal	North: Plot No. - LAND OF SUNDARI DEVI	
Project Type: Building Permission	South: Plot No. - T.P.P NO.- 524 PART	
Nature of Development: New	East: Plot No. - LAND AND HOUSE OF DILIP SAH	
Location of Development Area: Old Area	West: Road Width - 4.50	

AREA DETAILS:		SQ.MT.
AREA OF PLOT (Minimum)	(A)	47.50
NET AREA OF PLOT(Gross Plot Area - Deduction from Gross Plot area)	(A-Deductions)	47.50
Deduction for Balance Plot Area(from Gross Plot Area)		
Common Plot		10.69
Total		10.69
BALANCE AREA OF PLOT(Net Plot Area - Recreational/Amenity space)	(A-Deductions)	36.80
PLOT AREA FOR COVERAGE(Net Plot Area)	(A-Deductions)	47.50
Plot Area for FAR (Net Plot Area + Road Widening Area)	(A-Deductions)	47.50

COVERAGE CHECK		
Permissible Coverage area (70.00 %)		33.25
Proposed Coverage Area (56.00 %)		26.60
Total Prop. Coverage Area (56 %)		26.60
Balance coverage area (14.00 %)		6.65
FAR CHECK		
Perm. FAR Area (1.500)		71.25
Total Perm. FAR area		71.25
Residential FAR		53.19
Proposed FAR Area		60.77
Total Proposed FAR Area		60.77
Consumed FAR (Factor)		1.28
Balance FAR Area		10.48
BUILT UP AREA CHECK		
Total Proposed BuiltUp Area		79.79
ARCHITECT (Regd)	UJJAWAL KUMAR	
ENGINEER (Regd)		
SUPERVISOR (Regd)		
OWNER (Regd)	MANJU DEVI	
DEVELOPMENT AUTHORITY		LOCAL BODY

COLOR INDEX	
PLOT BOUNDARY	Black
ABUTTING ROAD	Green
PROPOSED CONSTRUCTION	Red
COMMON PLOT	Yellow
ROAD WIDENING AREA	Blue
EXISTING (To be retained)	Light Blue
EXISTING (To be demolished)	Dark Blue

Floor Name	Building Name A (MANJU DEVI)		Total	
	Proposed Built Up Area (Sq.mt.)	Proposed FAR Area (Sq.mt.)	Total Proposed Built Up Area (Sq.mt.)	Total FAR Area (Sq.mt.)
Ground Floor	26.59	7.57	26.59	7.57
First Floor	26.60	26.60	26.60	26.60
Second Floor	26.60	26.60	26.60	26.60
Terrace Floor	0.00	0.00	0.00	0.00
Total :	79.79	60.77	79.79	60.77

Building USE/SUBUSE Details			
Building Name	Building Use	Building SubUse	Building Structure
A (MANJU DEVI)	Residential	Bungalow/ Dwelling / Non Apartment	Non-Highrise

FAR & Tenement Details (Table 4c-1)								
Building	No. of Same Bldg	Total Built Up Area (Sq.mt.)	Deductions (Area in Sq.mt.)	Proposed FAR Area (Sq.mt.)	Add Area In FAR (Sq.mt.)	Total FAR Area (Sq.mt.)	Total Consumed Additional FAR Area (Sq.mt.)	Tnmt (No.)
A (MANJU DEVI)	1	79.79	19.02	53.20	7.57	60.77	60.77	01
Grand Total :	1	79.79	19.02	53.20	7.57	60.77	60.77	01

UnitBUA Table for Building :A (MANJU DEVI)						
FLOOR	Name	UnitBUA Type	UnitBUA Area	Carpet Area	No. of Rooms	No. of Tenement
SECOND FLOOR PLAN	SPLIT 1	FLAT	0.00	0.00	1	0
FIRST FLOOR PLAN	SPLIT 1	FLAT	34.39	33.92	3	1
Total:	-	-	34.39	33.92	4	1

LTP NAME AND SIGNATURE	STRUCTURAL ENG'S NAME AND SIGNATURE	BUILDER NAME AND SIGNATURE	DIGITAL SIGNATURE
UJJAWAL KUMAR DGMC/ENG/0005/2016			

This is certify that the structure design is in accordance with the latest I-S code(I-S 875,I-S456-2002, I-S 1893-2000) for design & loading conditions (Sessmic/wind/dead/live) and other all parameters are taken in account for safetyof the structure.

Building :A (MANJU DEVI)							
Floor Name	Total Built Up Area (Sq.mt.)	Deductions (Area in Sq.mt.)	Proposed FAR Area (Sq.mt.)	Add Area In FAR (Sq.mt.)	Total FAR Area (Sq.mt.)	Total Consumed Additional FAR Area (Sq.mt.)	Tnmt (No.)
Ground Floor	26.59	19.02	0.00	7.57	7.57	7.57	00
First Floor	26.60	0.00	26.60	0.00	26.60	26.60	01
Second Floor	26.60	0.00	26.60	0.00	26.60	26.60	00
Terrace Floor	0.00	0.00	0.00	0.00	0.00	0.00	00
Total :	79.79	19.02	53.20	7.57	60.77	60.77	01
Total Number of Same Buildings :	1						
Total :	79.79	19.02	53.20	7.57	60.77	60.77	01

SCHEDULE OF DOOR:				
BUILDING NAME	NAME	LENGTH	HEIGHT	NOS
A (MANJU DEVI)	D2	0.75	2.10	01
A (MANJU DEVI)	D	1.05	2.10	03

SCHEDULE OF WINDOW/VENTILATION:				
BUILDING NAME	NAME	LENGTH	HEIGHT	NOS
A (MANJU DEVI)	HLW3	0.90	0.60	01
A (MANJU DEVI)	W4	1.20	1.35	01
A (MANJU DEVI)	W5	1.50	1.35	04

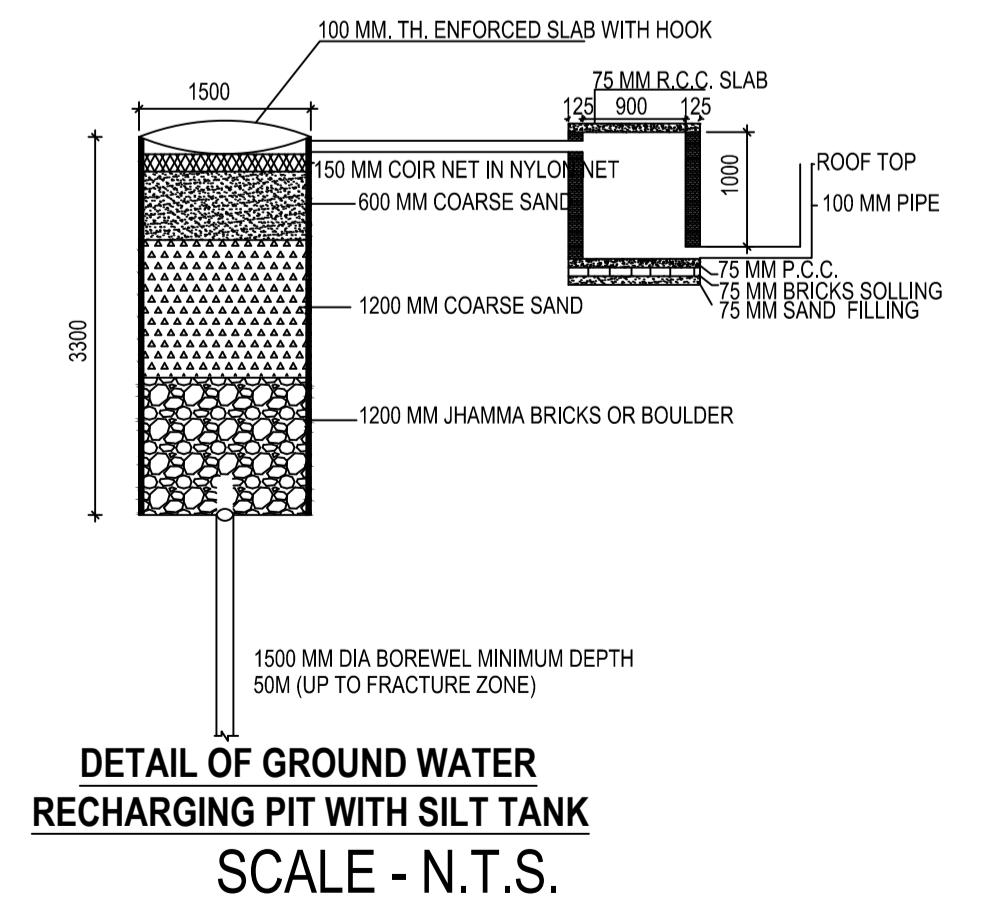

DETAIL OF GROUND WATER RECHARGING PIT WITH SILT TANK SCALE - N.T.S.

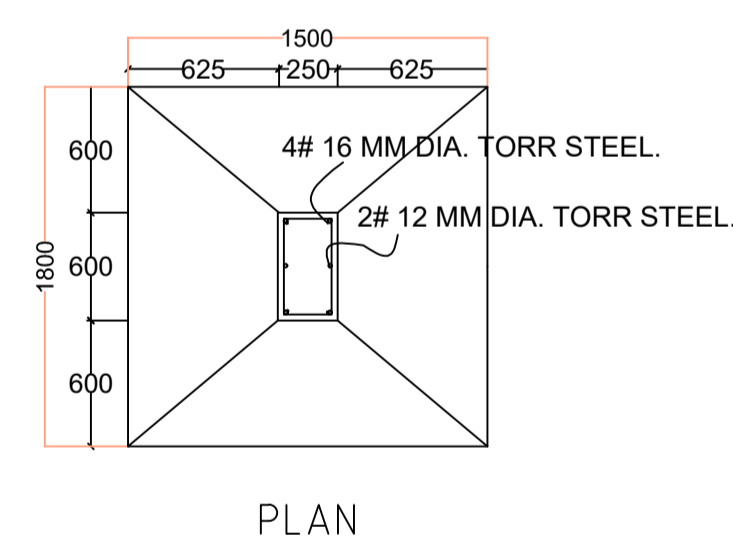

FOUNDATION DETAILS (ISOLATED R.C.C FOOTING)

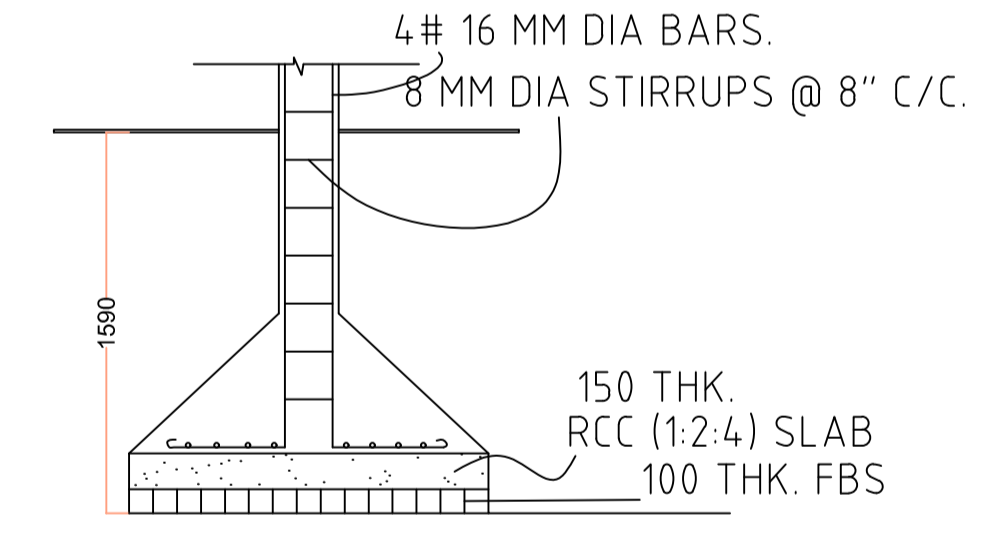

SECTION

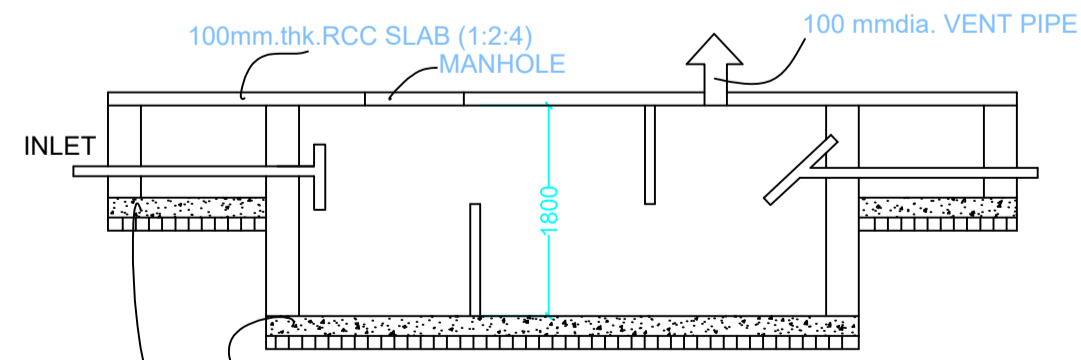

SECTION SCALE 1:50 SEPTIC TANK DETAILS

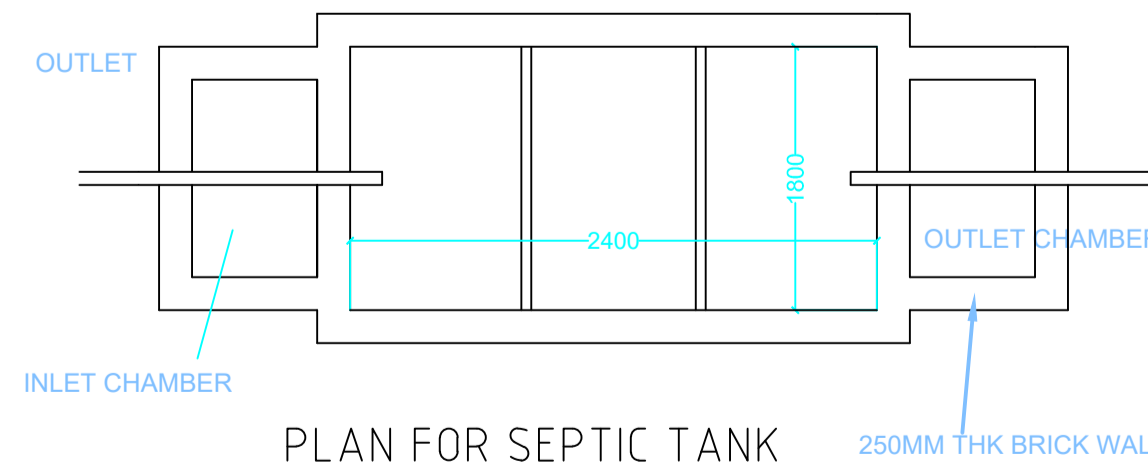

PLAN FOR SEPTIC TANK