

CROSS SECTION OF BEAM AT MIDDLE SPAN

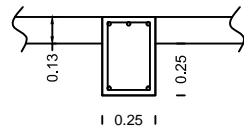

CROSS SECTION OF BEAM AT END SUPPORT

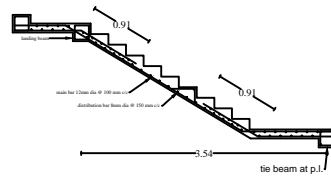

LONGITUDINAL SECTION 1ST FLIGHT

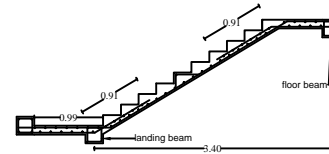

LONGITUDINAL SECTION 2ND FLIGHT

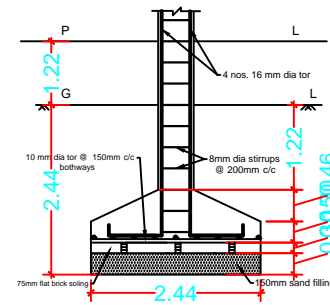

SECTIONAL VIEW OF ISOLATED FOOTING FOR COLUMN FOUNDATION SCALE-1:25

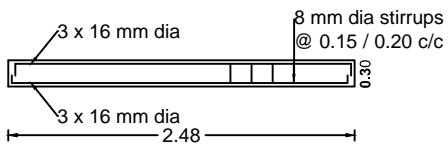

LONGITUDINAL SECTION OF LANDING BEAM

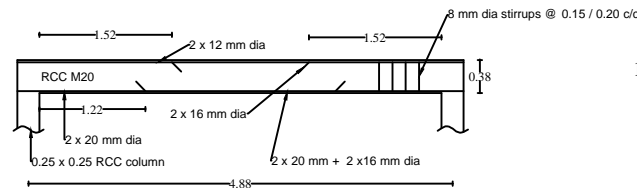

LONGITUDINAL SECTION OF ROOF BEAM

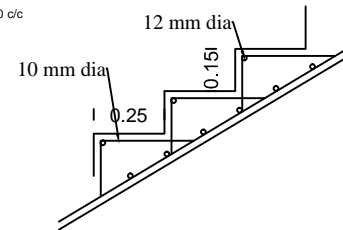

TYPICAL SECTION OF EACH STEP

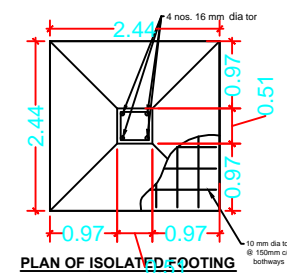

PLAN OF ISOLATED FOOTING FOR COLUMN FOUNDATION SCALE-1:25