

Project Title :SRI SANJEEV KUMAR DEO AND SRI CHIRANJEEV KUMAR DEO

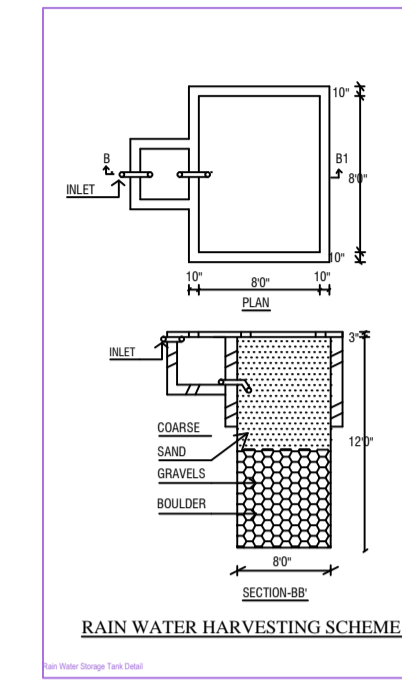
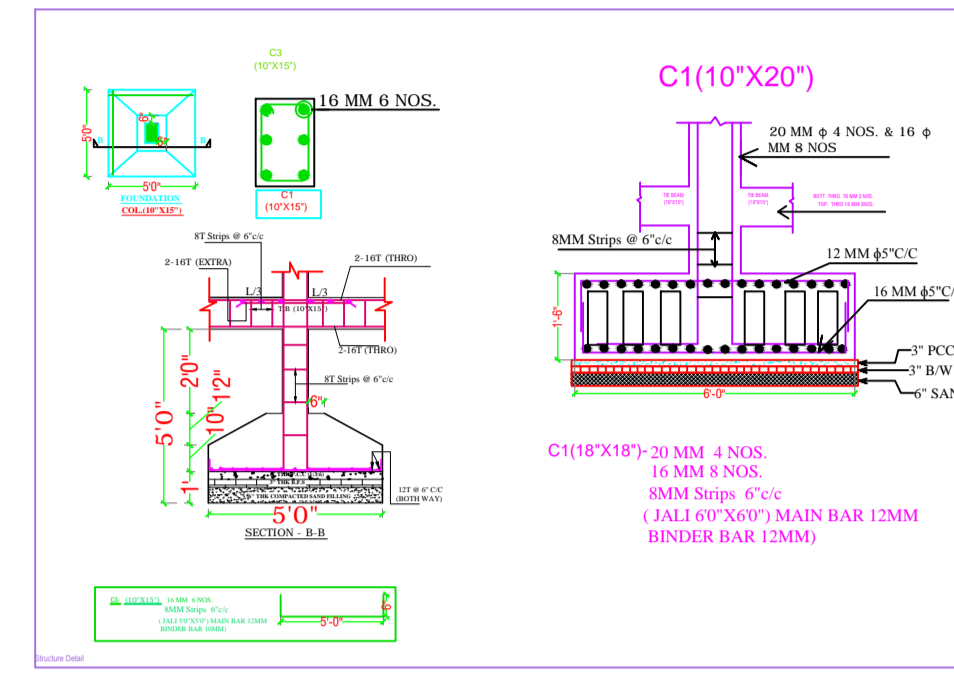
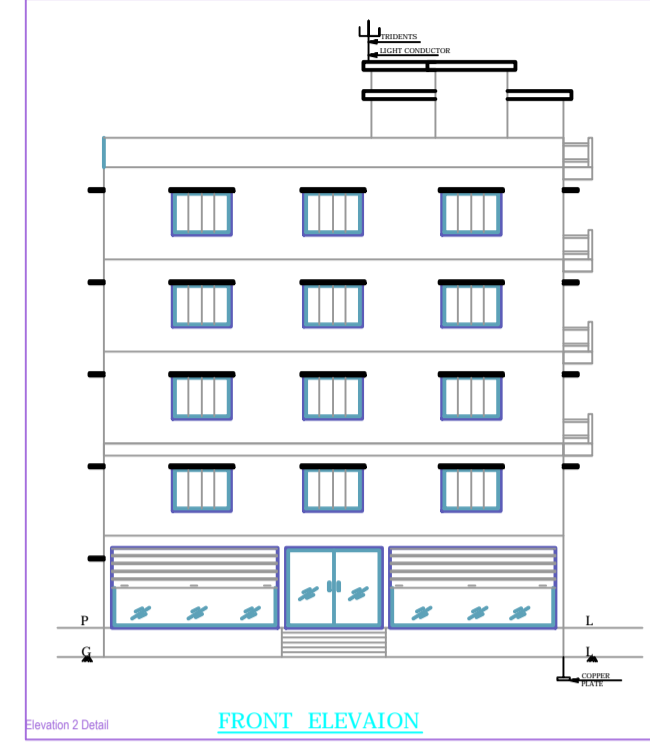

**SET BACK**

FRONT SET BACK-6041.5MM  
 REAR SET BACK-431.0MM  
 RIGHT SET BACK-348MM  
 LEFT SET BACK-248MM

**N:-15'0" WIDE ROAD.**  
**S:-JASDIGH TO DEOGHAR ROAD.**  
**E:-LAND OF R.N.RAY**  
**W:-40'0" WIDE ROAD.**

**SCHEDULE OF DOOR & WINDOW**

NO.	DOOR	WIDE	HT	HT	HT	HT	HT
D	3'6"	7'0"	+00	3'0" X 7'0"			
D	3'0"	7'0"	+05	3'0" X 7'0"			
D	2'6"	7'0"	+60	2'6" X 7'0"			

**AREA OF LAND (AS PER DEED)** :- 0.0 SQM  
**AREA OF LAND** :- 715.93 SQM

**LIFT AREA (I)** :- 3.85 SQM  
**LIFT AREA (II)** :- 2.80 SQM

**B.F BUILT UP AREA (I)** :- 342.08 SQM  
**G.F BUILT UP AREA (C)** :- 342.08 SQM  
**F.F BUILT UP AREA (C)** :- 342.08 SQM  
**S.F BUILT UP AREA (C)** :- 354.08 SQM  
**3RD F BUILT UP AREA (C)** :- 354.08 SQM  
**4TH F BUILT UP AREA (C)** :- 354.08 SQM

**FOR F.A.R.:-**  
**G.F BUILT UP AREA (C)** :- 335.41 SQM  
**F.F BUILT UP AREA (C)** :- 335.41 SQM  
**S.F BUILT UP AREA (C)** :- 348.33 SQM  
**3RD F BUILT UP AREA (C)** :- 348.33 SQM  
**4TH F BUILT UP AREA (C)** :- 348.33 SQM

**F.A.R.** :- 2.39  
**G.F. COVERAGE AREA** :- 47.77%  
**TOTAL BUILDING HEIGHT** :- 14375MM

**PROPOSED WORKS**

NO.	DESCRIPTION	UNIT	QUANTITY	EST. PRICE	TOTAL
1	Excavation	m <sup>3</sup>	100	1000	1000
2	Concrete	m <sup>3</sup>	200	4000	4000
3	Brickwork	m <sup>2</sup>	500	10000	10000
4	Plaster	m <sup>2</sup>	1000	2000	2000
5	Painting	m <sup>2</sup>	2000	4000	4000
6	Roofing	m <sup>2</sup>	1000	2000	2000
7	Electrical	nos	100	2000	2000
8	Sanitary	nos	50	1000	1000
9	Water supply	m	100	2000	2000
10	Drainage	m	100	2000	2000
11	Landscaping	nos	100	2000	2000
12	Site work	nos	100	2000	2000
13	Contingency	%		10000	10000
14	Professional fee	%		10000	10000
15	Other charges	%		10000	10000
16	Grand Total			100000	100000

**COLOR INDEX**

**PARKING CALCULATION**

Category	Area (sqm)	Capacity
Open	1000	20
Covered	500	10
Total	1500	30

**MARGIN DETAIL**

Side	Front	Side	Rear
Open	1.50	1.50	1.50
Covered	1.50	1.50	1.50

**PROPOSED WORKS (Table 40-1)**

Sl. No.	Particulars	Unit	Quantity	Rate	Amount
1	Excavation	m <sup>3</sup>	100	1000	1000
2	Concrete	m <sup>3</sup>	200	4000	4000
3	Brickwork	m <sup>2</sup>	500	10000	10000
4	Plaster	m <sup>2</sup>	1000	2000	2000
5	Painting	m <sup>2</sup>	2000	4000	4000
6	Roofing	m <sup>2</sup>	1000	2000	2000
7	Electrical	nos	100	2000	2000
8	Sanitary	nos	50	1000	1000
9	Water supply	m	100	2000	2000
10	Drainage	m	100	2000	2000
11	Landscaping	nos	100	2000	2000
12	Site work	nos	100	2000	2000
13	Contingency	%		10000	10000
14	Professional fee	%		10000	10000
15	Other charges	%		10000	10000
16	Grand Total			100000	100000

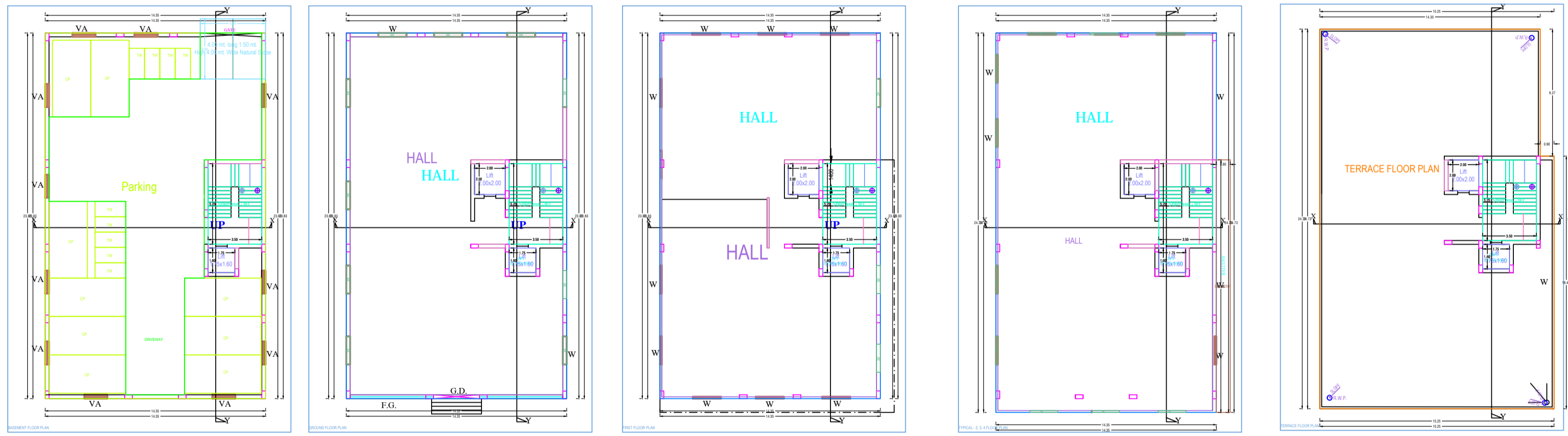
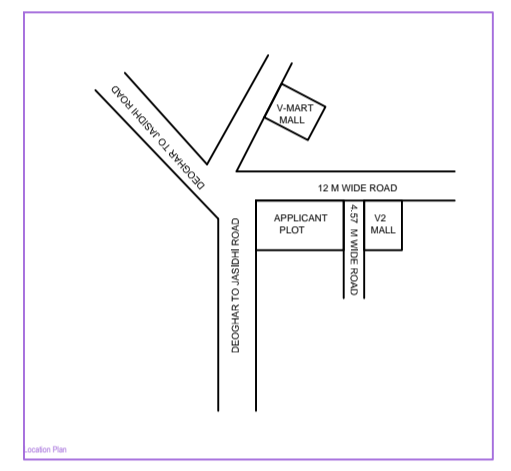
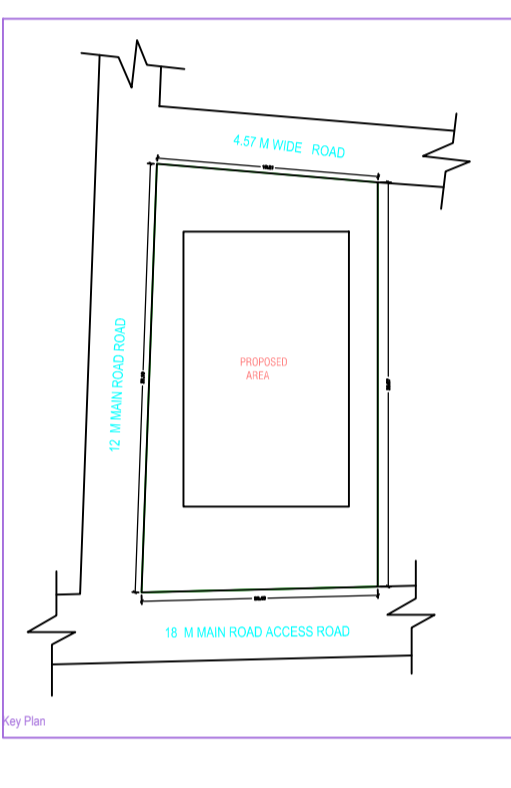
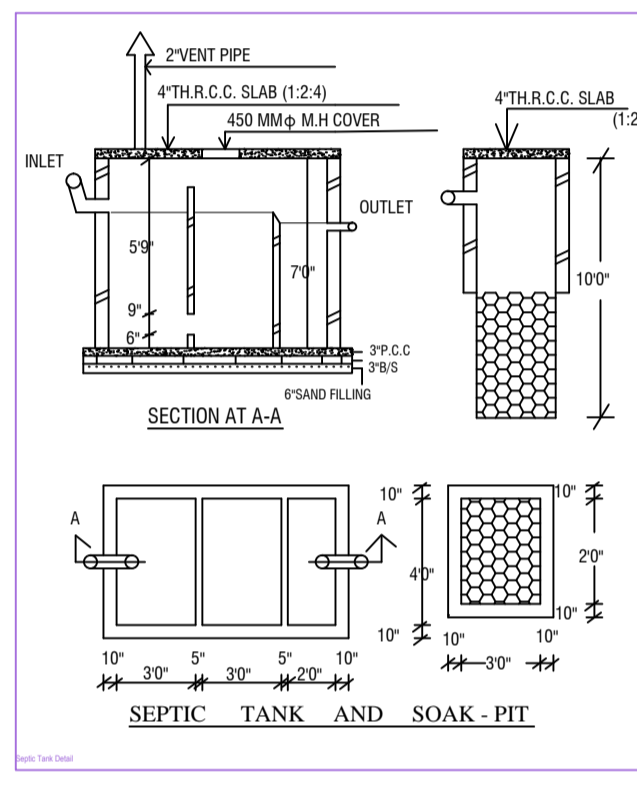
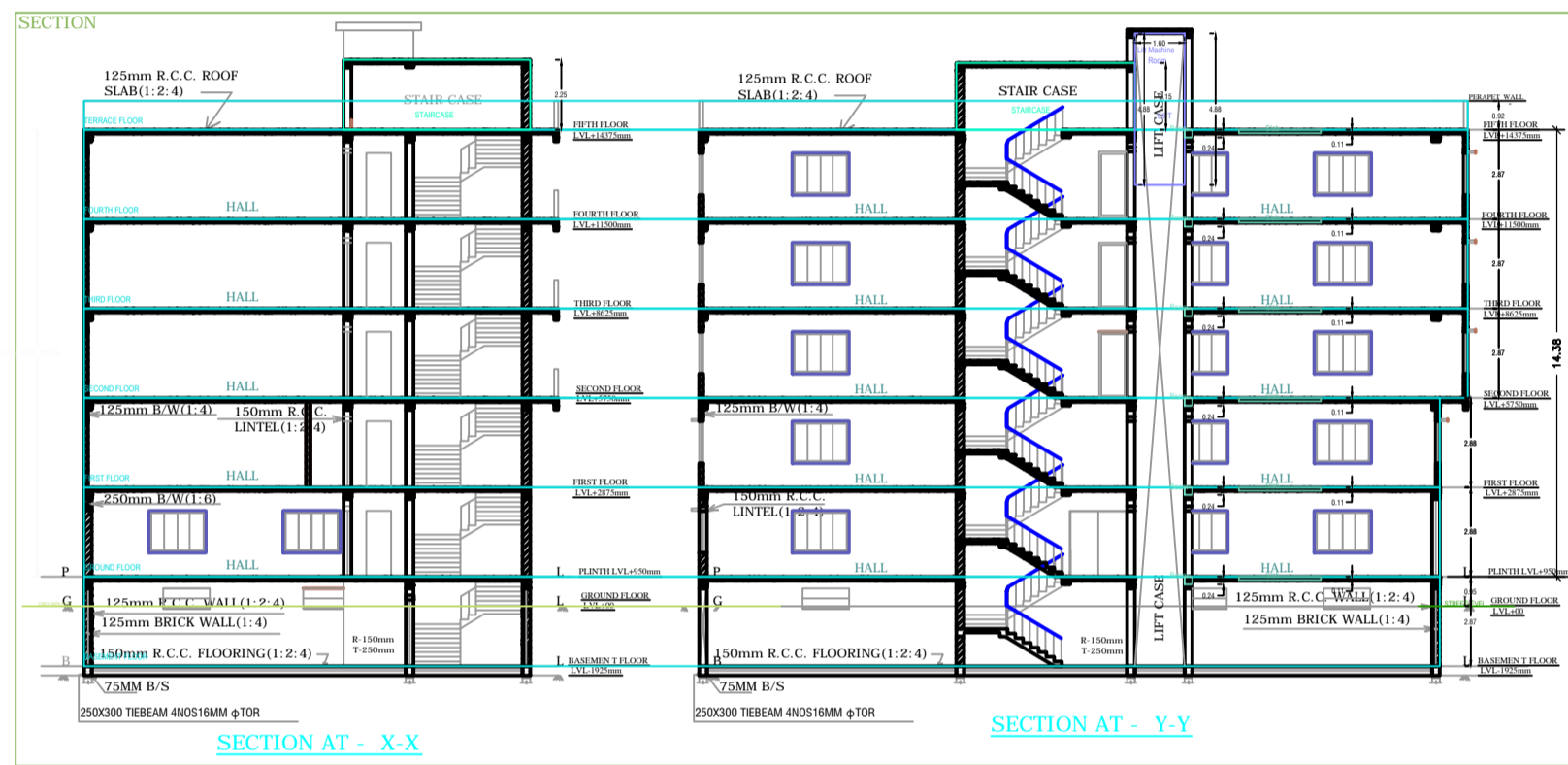
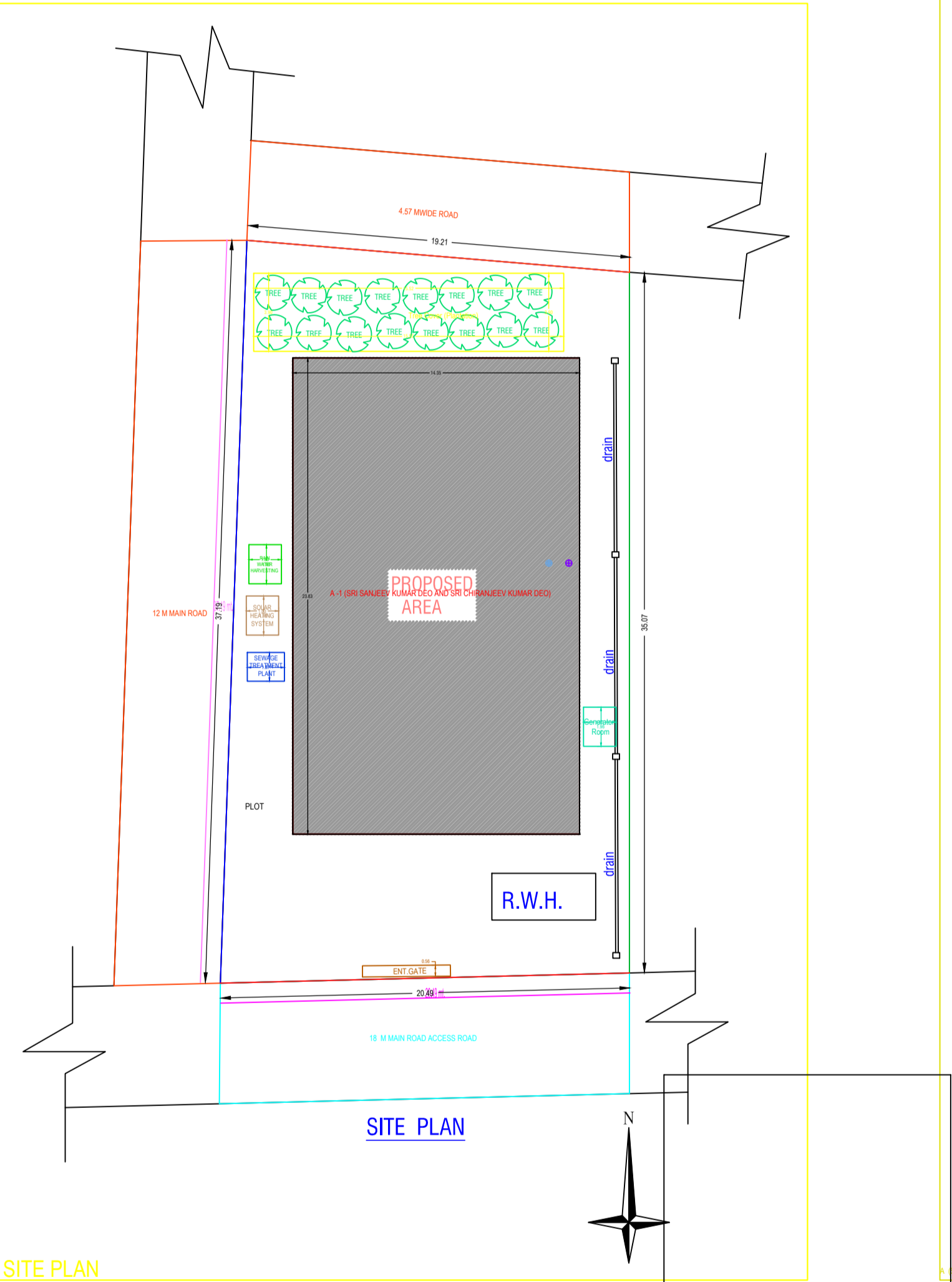

**PLAN ELEVATION AND DETAILS**  
**DRAWING OF A COMMERCIAL BUILDING BY SRI SANJEEV KUMAR DEO & SRI CHIRANJEEV KUMAR DEO.**  
 UNDER MOUZA:-MADHUSUDAN CHARAT NO:-255. J.B. NO:-11/2012. T.P. PLOT NO:-370. UNDER DEOGHAR NAGAR NIGAM (JHARKHAND).

OWNER SING.

SIGN. OF ENGG.

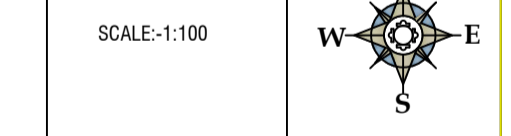

**Building A (SRI SANJEEV KUMAR DEO AND SRI CHIRANJEEV KUMAR DEO)**

**PROPOSED WORKS**

Sl. No.	Particulars	Unit	Quantity	Rate	Amount
1	Excavation	m <sup>3</sup>	100	1000	1000
2	Concrete	m <sup>3</sup>	200	4000	4000
3	Brickwork	m <sup>2</sup>	500	10000	10000
4	Plaster	m <sup>2</sup>	1000	2000	2000
5	Painting	m <sup>2</sup>	2000	4000	4000
6	Roofing	m <sup>2</sup>	1000	2000	2000
7	Electrical	nos	100	2000	2000
8	Sanitary	nos	50	1000	1000
9	Water supply	m	100	2000	2000
10	Drainage	m	100	2000	2000
11	Landscaping	nos	100	2000	2000
12	Site work	nos	100	2000	2000
13	Contingency	%		10000	10000
14	Professional fee	%		10000	10000
15	Other charges	%		10000	10000
16	Grand Total			100000	100000

**SCHEDULE OF ENERGY**

Sl. No.	Particulars	Unit	Quantity	Rate	Amount
1	Excavation	m <sup>3</sup>	100	1000	1000
2	Concrete	m <sup>3</sup>	200	4000	4000
3	Brickwork	m <sup>2</sup>	500	10000	10000
4	Plaster	m <sup>2</sup>	1000	2000	2000
5	Painting	m <sup>2</sup>	2000	4000	4000
6	Roofing	m <sup>2</sup>	1000	2000	2000
7	Electrical	nos	100	2000	2000
8	Sanitary	nos	50	1000	1000
9	Water supply	m	100	2000	2000
10	Drainage	m	100	2000	2000
11	Landscaping	nos	100	2000	2000
12	Site work	nos	100	2000	2000
13	Contingency	%		10000	10000
14	Professional fee	%		10000	10000
15	Other charges	%		10000	10000
16	Grand Total			100000	100000

**UMBRA Table for Building A (SRI SANJEEV KUMAR DEO AND SRI CHIRANJEEV KUMAR DEO)**

Sl. No.	Particulars	Unit	Quantity	Rate	Amount
1	Excavation	m <sup>3</sup>	100	1000	1000
2	Concrete	m <sup>3</sup>	200	4000	4000
3	Brickwork	m <sup>2</sup>	500	10000	10000
4	Plaster	m <sup>2</sup>	1000	2000	2000
5	Painting	m <sup>2</sup>	2000	4000	4000
6	Roofing	m <sup>2</sup>	1000	2000	2000
7	Electrical	nos	100	2000	2000
8	Sanitary	nos	50	1000	1000
9	Water supply	m	100	2000	2000
10	Drainage	m	100	2000	2000
11	Landscaping	nos	100	2000	2000
12	Site work	nos	100	2000	2000
13	Contingency	%		10000	10000
14	Professional fee	%		10000	10000
15	Other charges	%		10000	10000
16	Grand Total			100000	100000