

Proposal Basic Information

Proposal File No.	DGMC/BP/0037/W30/2023
Owner Name	DILIP KUMAR MANDAL
Khata No	234/2 & 234/3
Plot No	T.P PLOT NO- 548
Village Name	Deoghar
Use	Residential
SubUse	Bungalow/ Dwelling / Non Apartment

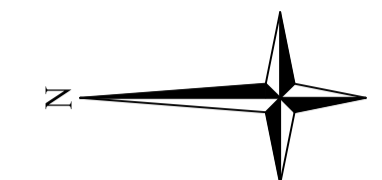

AREA STATEMENT DEOGHAR MUNICIPAL CORPORATION	VERSION NO.: 1.0.66 VERSION DATE: 16/10/2020
PROJECT DETAIL:	
Region: JHARKHAND URBAN LOCAL BODIES	Plot Use: Residential
District: DEOGHAR	Plot SubUse: Bungalow/ Dwelling / Non Apartment
Authority: DEOGHAR MUNICIPAL CORPORATION	PlotNearby/ReligiousStructure: NA
Inward No: DGMC/BP/0037/W30/2023	Plot/SubPlot No: T.P PLOT NO- 548
Application Type: General Proposal	North: Plot No. - SUB PLOT NO. - 1
Project Type: Building Permission	South: Plot No. - SUB PLOT NO. - 3 & 4
Nature of Development: New	East: Plot No. - SUB PLOT NO. - 7
Location of Development Area: Old Area	West: Road Width - 12.20

AREA DETAILS:		SQ.MT.
AREA OF PLOT (Minimum)	(A)	93.50
NET AREA OF PLOT(Gross Plot Area - Deduction from Gross Plot area)	(A-Deductions)	93.50
Deduction for Balance Plot Area(from Gross Plot Area)		
Common Plot		17.06
Total		17.06
BALANCE AREA OF PLOT(Net Plot Area - Recreational/Amenity space)	(A-Deductions)	76.44
PLOT AREA FOR COVERAGE(Net Plot Area)	(A-Deductions)	93.50
Plot Area for FAR (Net Plot Area + Road Widening Area)	(A-Deductions)	93.50
COVERAGE CHECK		
Permissible Coverage area (70.00 %)		65.45
Proposed Coverage Area (61.99 %)		57.96
Total Prop. Coverage Area (61.99 %)		57.96
Balance coverage area (8.01 %)		7.49
FAR CHECK		
Perm. FAR Area (2.500)		233.75
Total Perm. FAR area		233.75
Residential FAR		118.74
Proposed FAR Area		127.28
Total Proposed FAR Area		127.28
Consumed FAR (Factor)		1.36
Balance FAR Area		106.47
BUILT UP AREA CHECK		
Total Proposed BuiltUp Area		179.51
ARCHITECT (Regd)	UJJAWAL KUMAR	
ENGINEER (Regd)		
SUPERVISOR (Regd)		
OWNER (Regd)	DILIP KUMAR MANDAL	
DEVELOPMENT AUTHORITY	LOCAL BODY	

COLOR INDEX	
PLOT BOUNDARY	Black
ABUTTING ROAD	Green
PROPOSED CONSTRUCTION	Red
COMMON PLOT	Yellow
ROAD WIDENING AREA	Blue
EXISTING (To be retained)	Orange
EXISTING (To be demolished)	Grey

Buildingwise Floor FAR Details			
Floor Name	Building Name	Total	
	A (DILIP KUMAR MANDAL AND NILAMBAR MANDAL)		
Ground Floor	Proposed Built Up Area (Sq.mt.)	Proposed FAR Area (Sq.mt.)	Total Proposed Built Up Area (Sq.mt.)
First Floor	57.96	8.54	57.96
Second Floor	63.59	60.78	63.59
Terrace Floor	0.00	0.00	0.00
Total	179.51	127.28	179.51

Building USE/SUBUSE Details			
Building Name	Building Use	Building SubUse	Building Structure
A (DILIP KUMAR MANDAL AND NILAMBAR MANDAL)	Residential	Bungalow/ Dwelling / Non Apartment	Non-Highrise

FAR & Tenement Details (Table 4c-1)									
Building	No. of Same Bldg	Total Built Up Area (Sq.mt.)	Deductions (Area in Sq.mt.)	Proposed FAR Area (Sq.mt.)	Add Area In FAR (Sq.mt.)	Total FAR Area (Sq.mt.)	Total Consumed Additional FAR Area (Sq.mt.)	Tnmt (No.)	
A (DILIP KUMAR MANDAL AND NILAMBAR MANDAL)	1	179.51	2.81	49.42	118.74	8.54	127.28	127.28	01
Grand Total	1	179.51	2.81	49.42	118.74	8.54	127.28	127.28	01

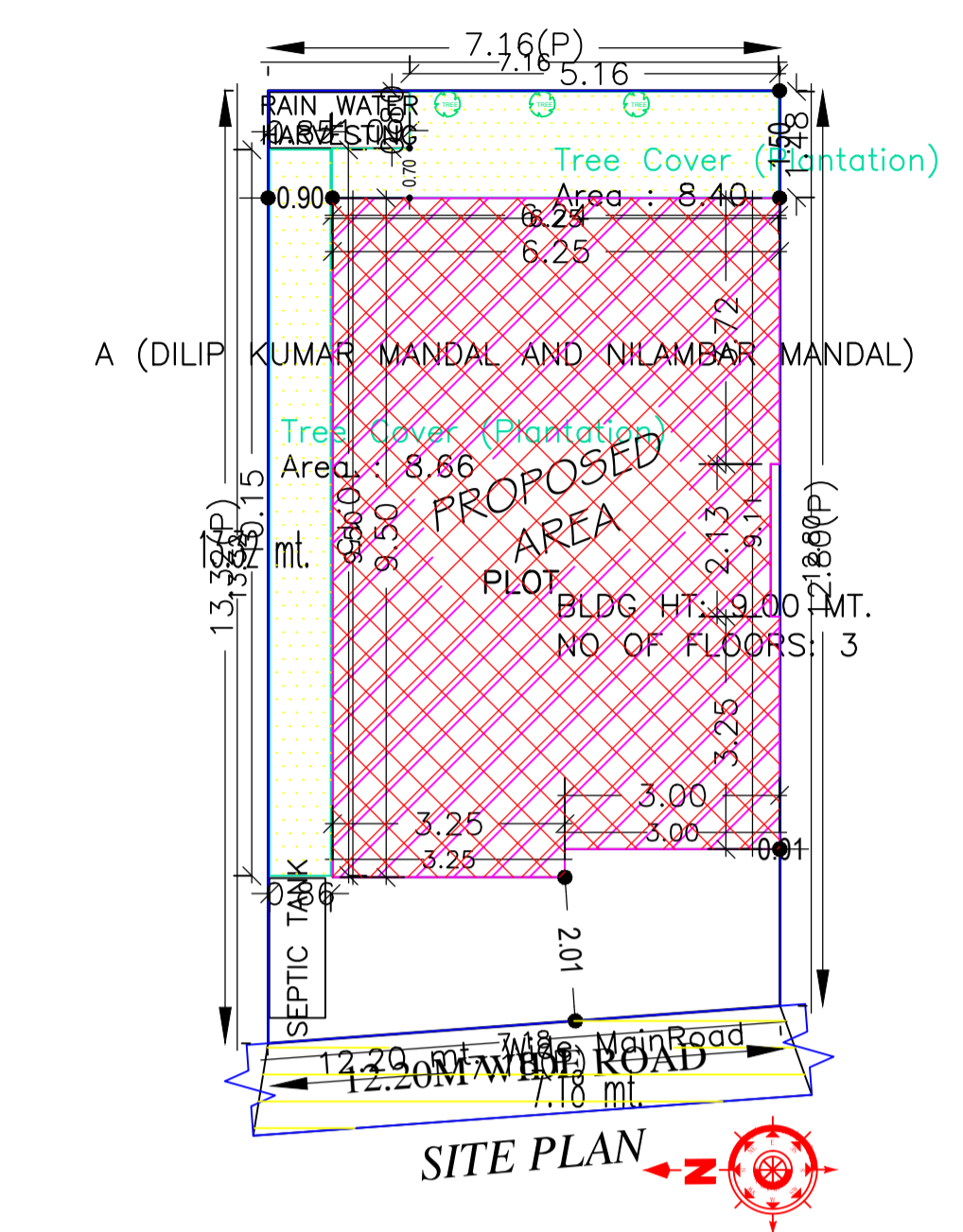

SITE PLAN

This is certify that the structure design is in accordance with the latest I-S code(I-S 875,I-S456-2002, I-S 1893-2000) for design & loading conditions (Sessmic/wind/dead/live) and other all parameters are taken in account for safetyof the structure.

UnitBUA Table for Building :A (DILIP KUMAR MANDAL AND NILAMBAR MANDAL)

FLOOR	Name	UnitBUA Type	UnitBUA Area	Carpet Area	No. of Rooms	No. of Tenement
FIRST FLOOR PLAN	SPLIT 1	FLAT	100.50	94.63	5	1
SECOND FLOOR PLAN	SPLIT 1	FLAT	0.00	0.00	5	0
Total:	-	-	100.50	94.63	10	1

Building :A (DILIP KUMAR MANDAL AND NILAMBAR MANDAL)

Floor Name	Total Built Up Area (Sq.mt.)	Deductions (Area in Sq.mt.)	Proposed FAR Area (Sq.mt.)	Add Area In FAR (Sq.mt.)	Total FAR Area (Sq.mt.)	Total Consumed Additional FAR Area (Sq.mt.)	Tnmt (No.)
Ground Floor	57.96	0.00	49.42	0.00	8.54	8.54	00
First Floor	57.96	0.00	0.00	0.00	57.96	57.96	01
Second Floor	63.59	2.81	0.00	60.78	0.00	60.78	00
Terrace Floor	0.00	0.00	0.00	0.00	0.00	0.00	00
Total:	179.51	2.81	49.42	118.74	8.54	127.28	01

SCHEDULE OF DOOR:

BUILDING NAME	NAME	LENGTH	HEIGHT	NOS
A (DILIP KUMAR MANDAL AND NILAMBAR MANDAL)	D2	0.75	2.10	02
A (DILIP KUMAR MANDAL AND NILAMBAR MANDAL)	D1	0.90	2.10	03
A (DILIP KUMAR MANDAL AND NILAMBAR MANDAL)	D	1.05	2.10	06

SCHEDULE OF WINDOW/VENTILATION:

BUILDING NAME	NAME	LENGTH	HEIGHT	NOS
A (DILIP KUMAR MANDAL AND NILAMBAR MANDAL)	HLW3	0.90	0.45	02
A (DILIP KUMAR MANDAL AND NILAMBAR MANDAL)	W4	1.20	1.35	02
A (DILIP KUMAR MANDAL AND NILAMBAR MANDAL)	W5	1.50	1.35	10

Balcony Calculations Table

FLOOR	SIZE	AREA	TOTAL AREA
SECOND FLOOR PLAN	0.90 X 3.25 X 1 X 1	2.93	5.63
Total	0.90 X 3.00 X 1 X 1	2.70	5.63

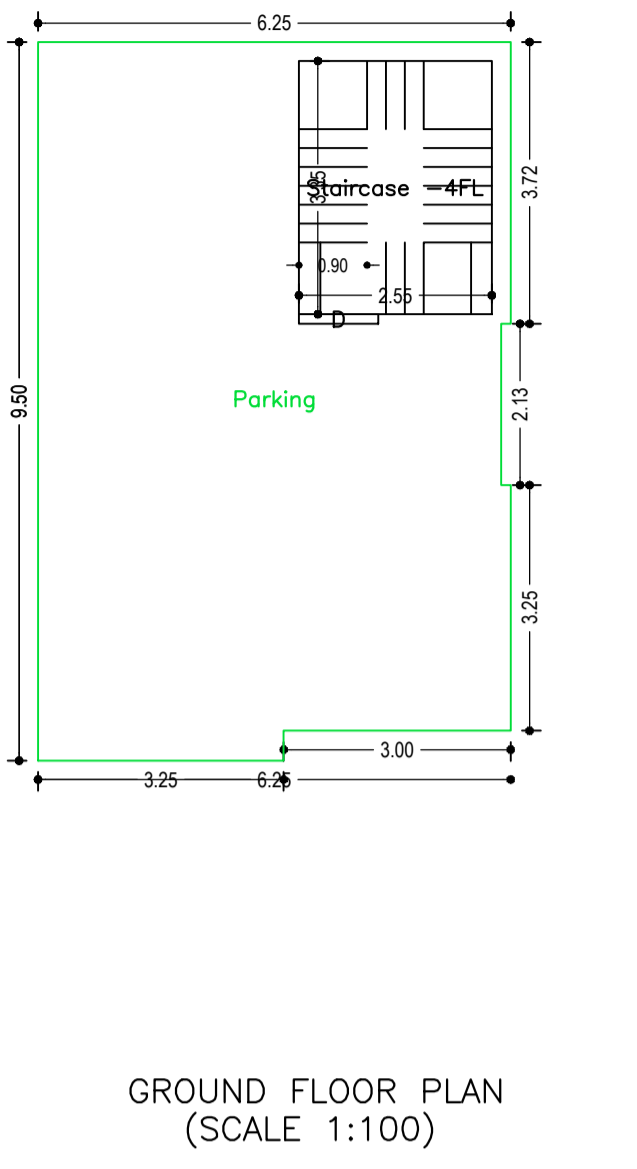

GROUND FLOOR PLAN (SCALE 1:100)

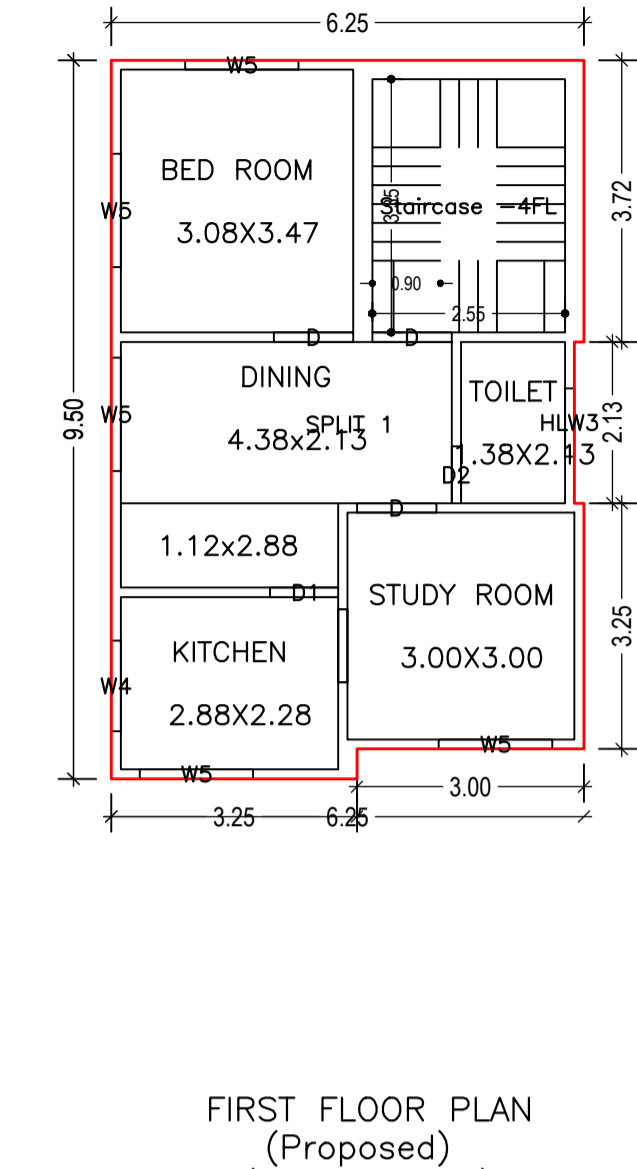

FIRST FLOOR PLAN (Proposed) (SCALE 1:100)

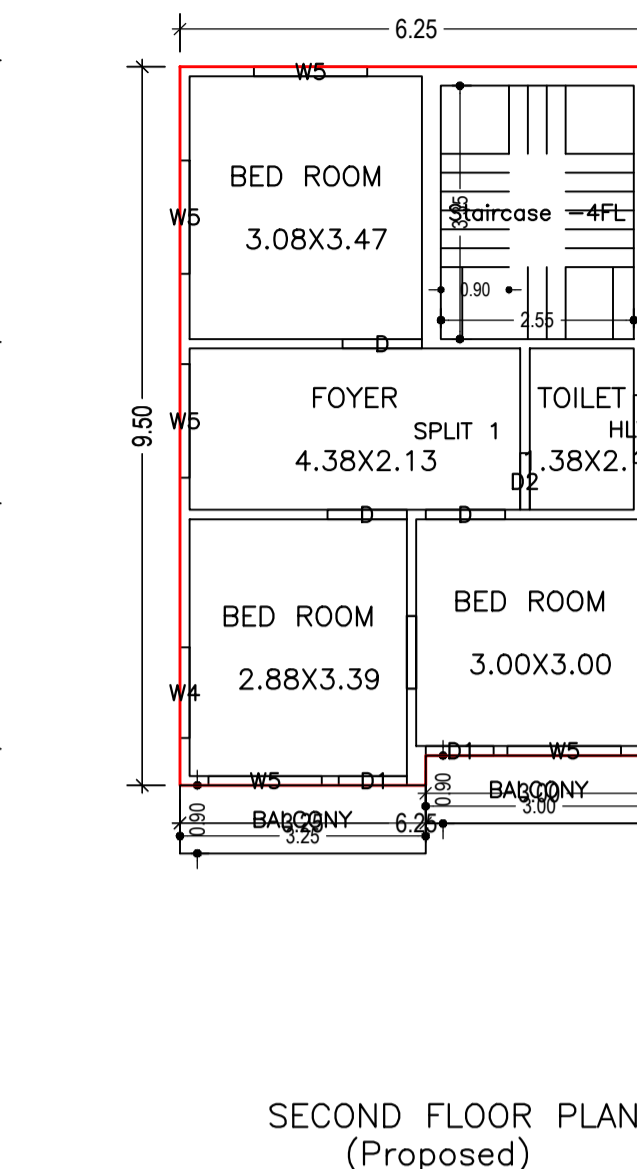

SECOND FLOOR PLAN (Proposed) (SCALE 1:100)

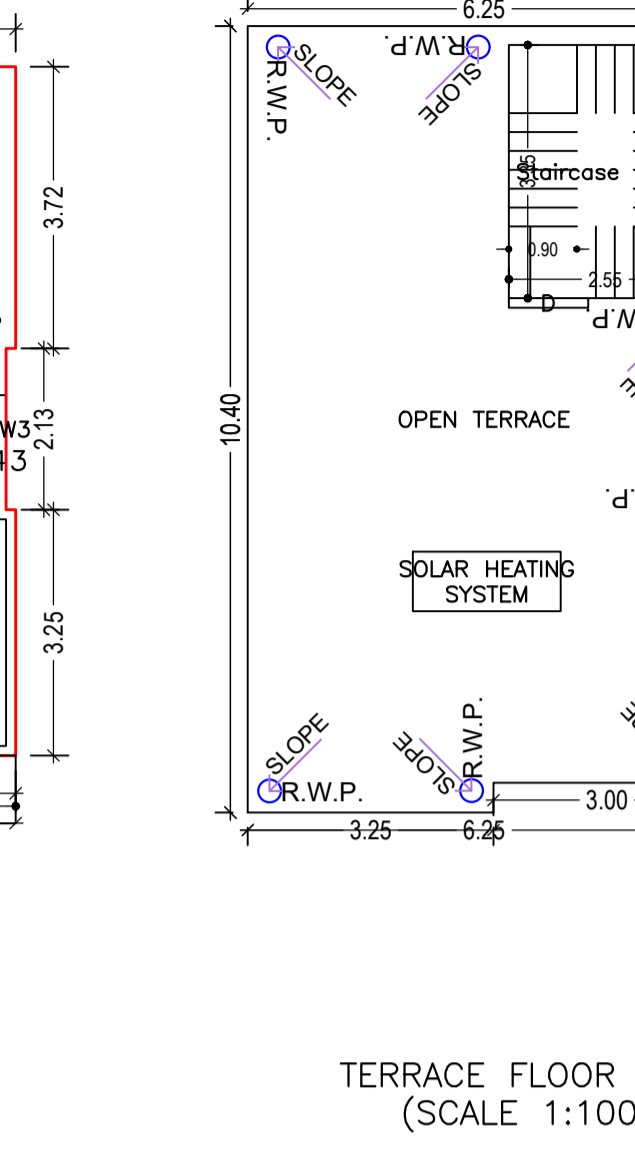

TERRACE FLOOR PLAN (SCALE 1:100)

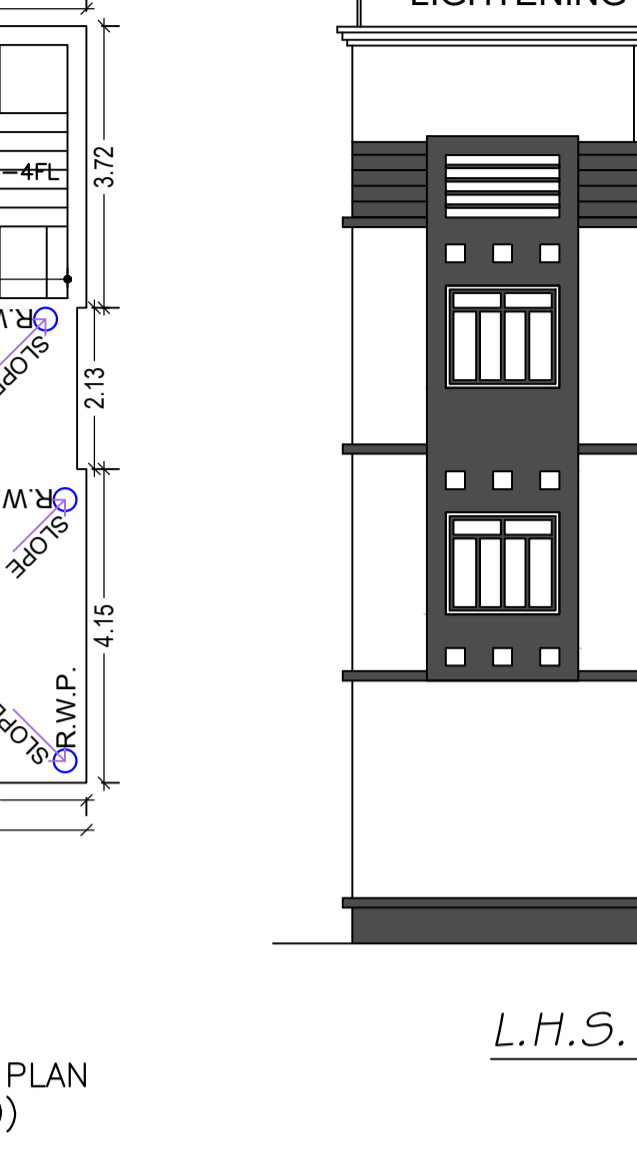

L.H.S. ELEVATION

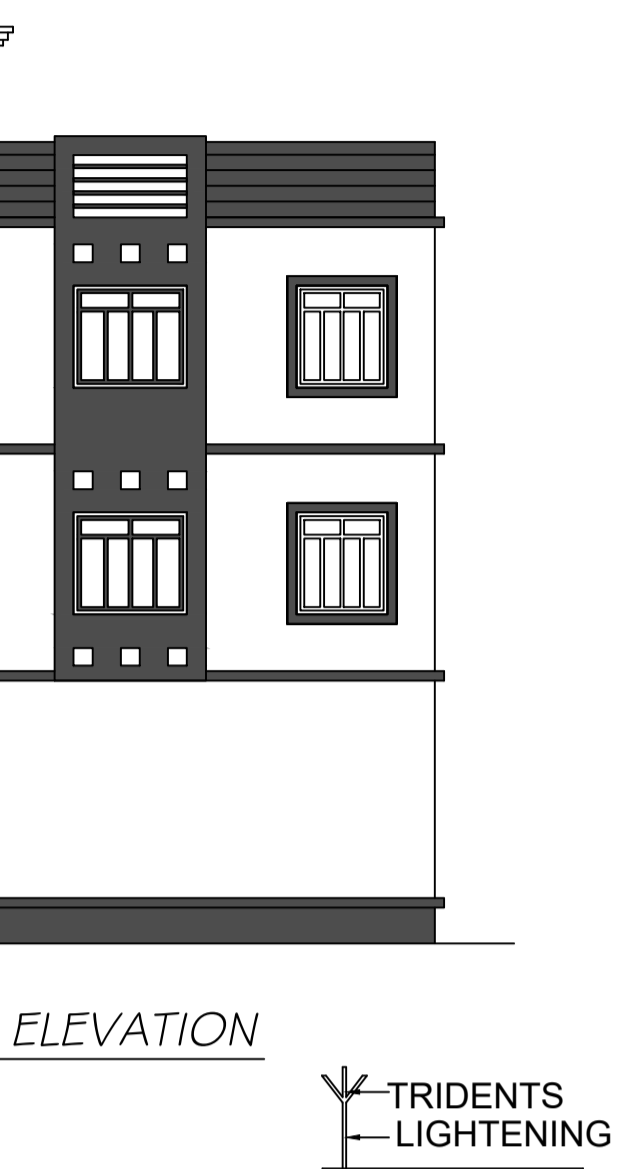

FRONT ELEVATION

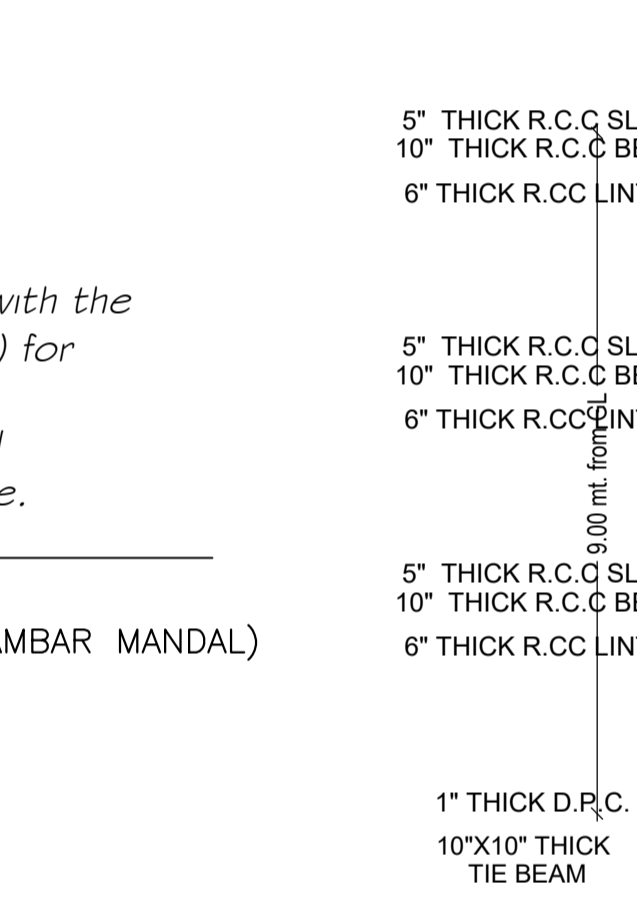

SECTION ON A-A

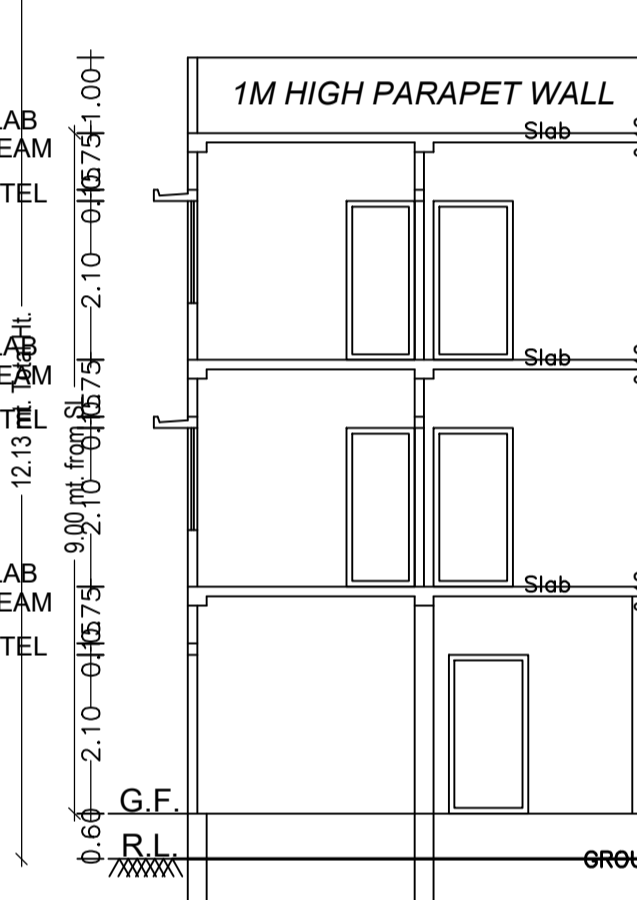

SECTION ON B-B

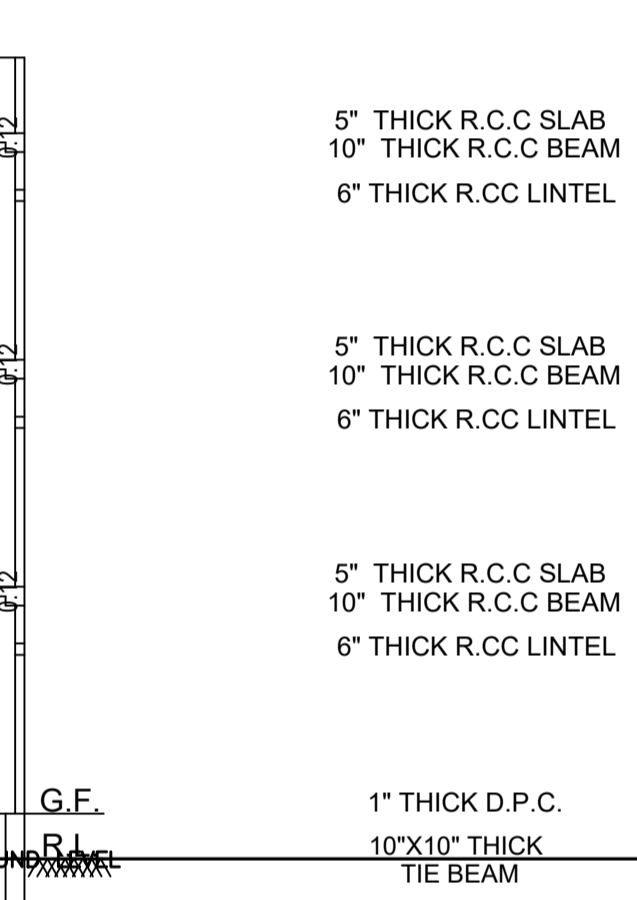

PLAN FOR SEPTIC TANK

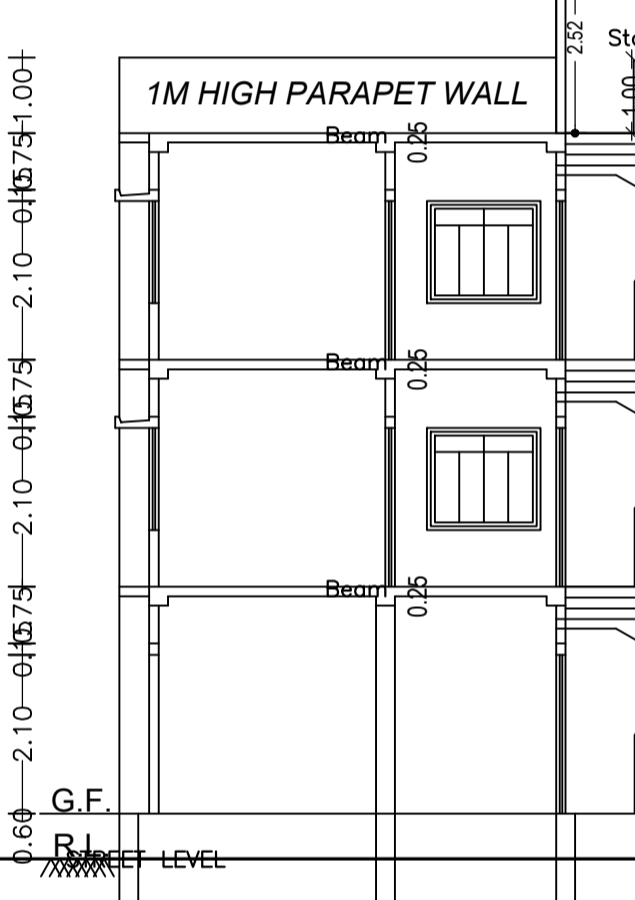

KEY PLAN

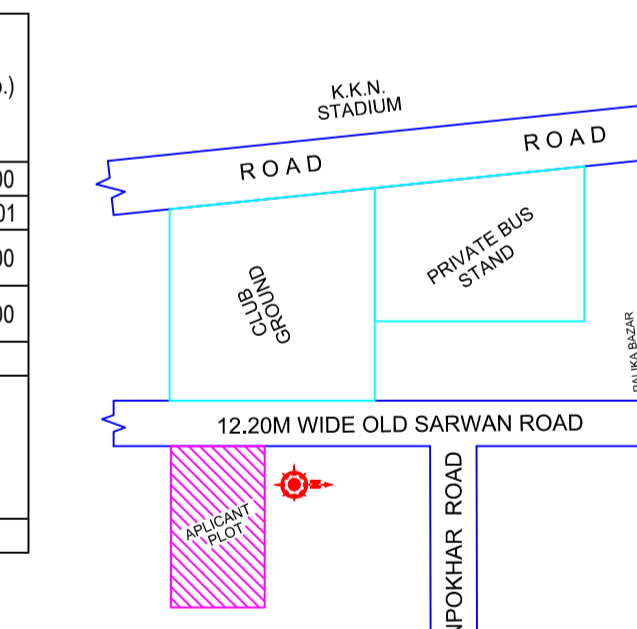

LOCATION MAP

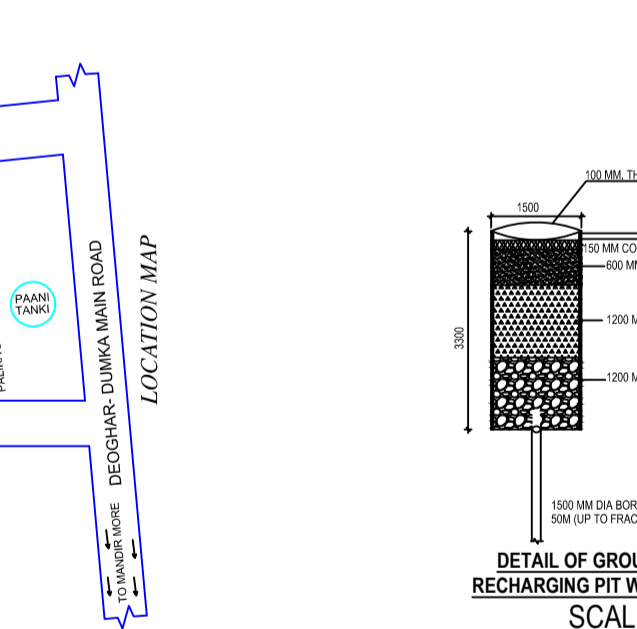

DETAIL OF GROUND WATER RECHARGING PIT WITH SILT TANK SCALE - N.T.S.

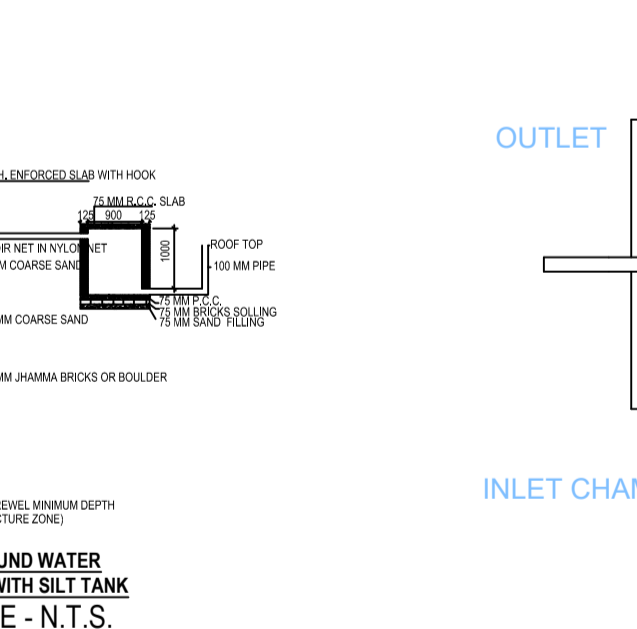

FOUNDATION DETAILS (ISOLATED R.C.C FOOTING)

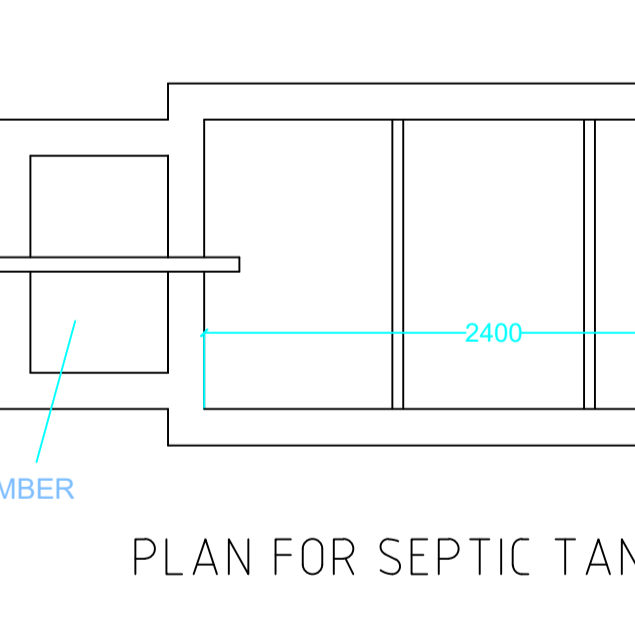

SECTION

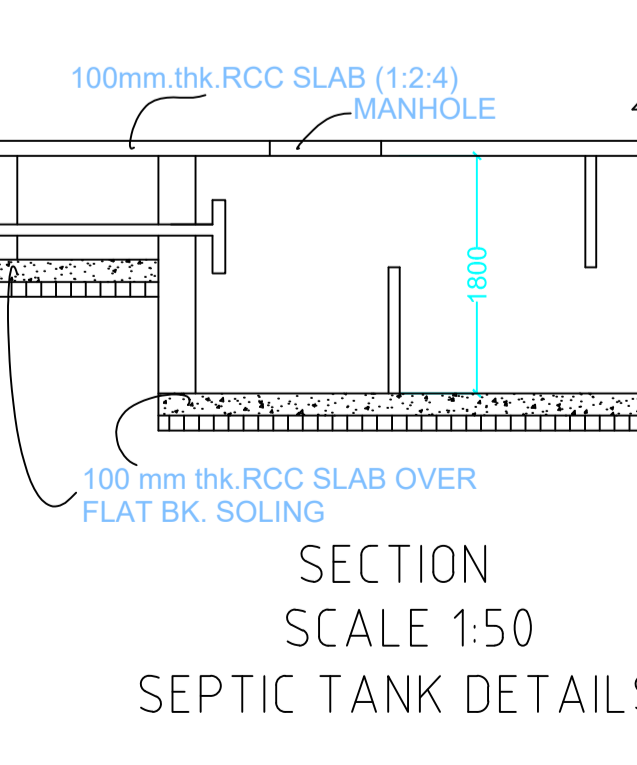

SECTION SCALE 1:50 SEPTIC TANK DETAILS

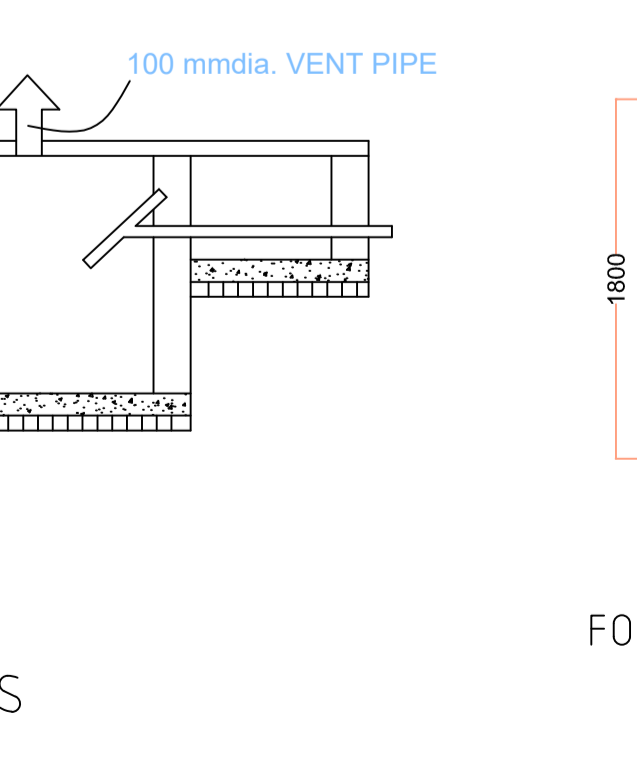

PLAN

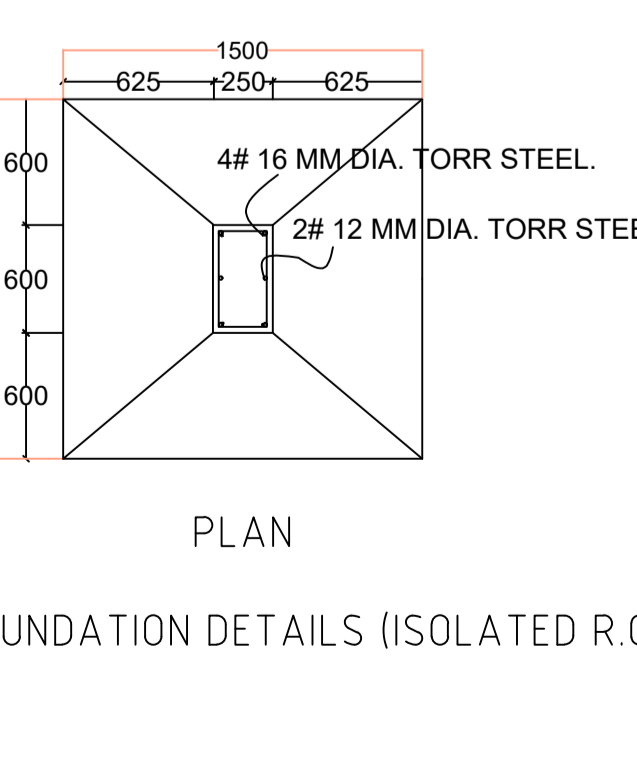

SECTION

LTP NAME AND SIGNATURE	STRUCTURAL ENG'S NAME AND SIGNATURE	BUILDER NAME AND SIGNATURE	DIGITAL SIGNATURE
UJJAWAL KUMAR DGMC/ENG/0005/2016			