

Proposal Basic Information

Proposal File No.	DGMC/BP/0018/W28/2024
Owner Name	SARIKA TIWARY
Khata No	1130
Plot No	T.P.P. NO.- 627
Village Name	Deoghar
Use	Residential
SubUse	Bungalow/ Dwelling / Non Apartment

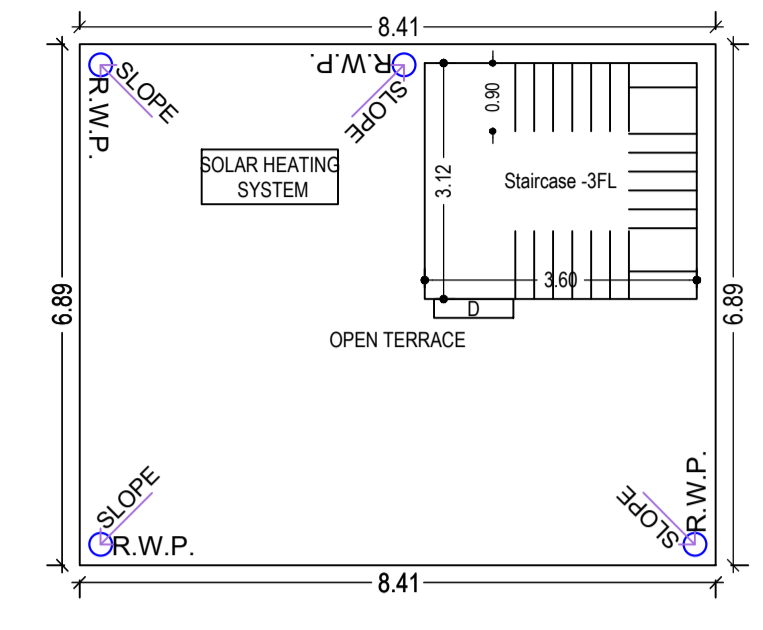
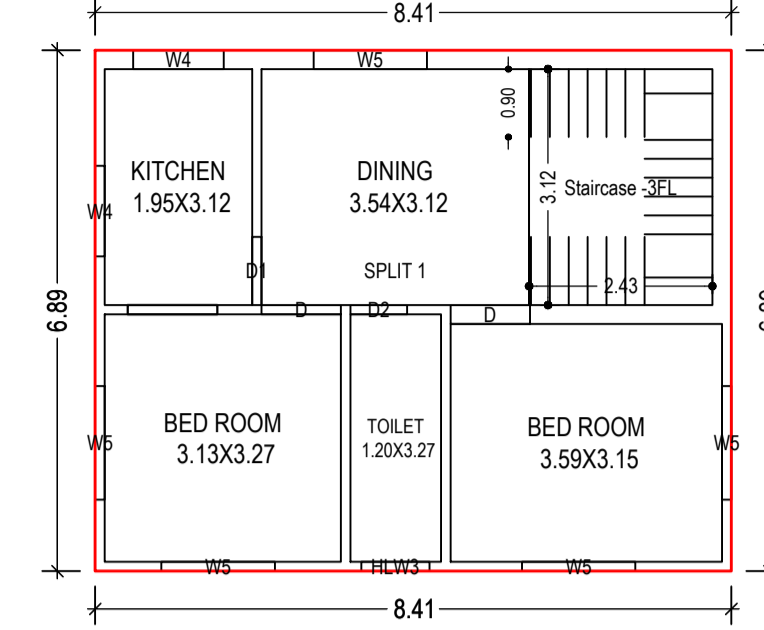
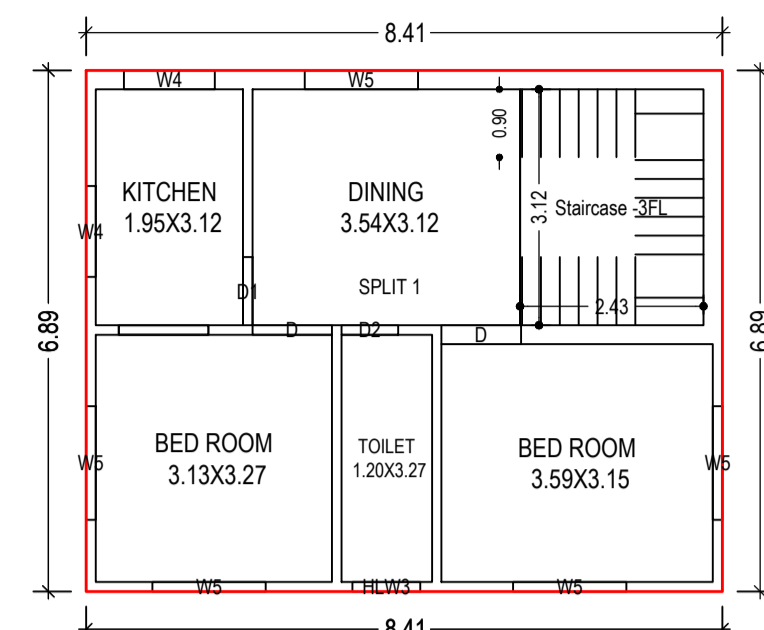
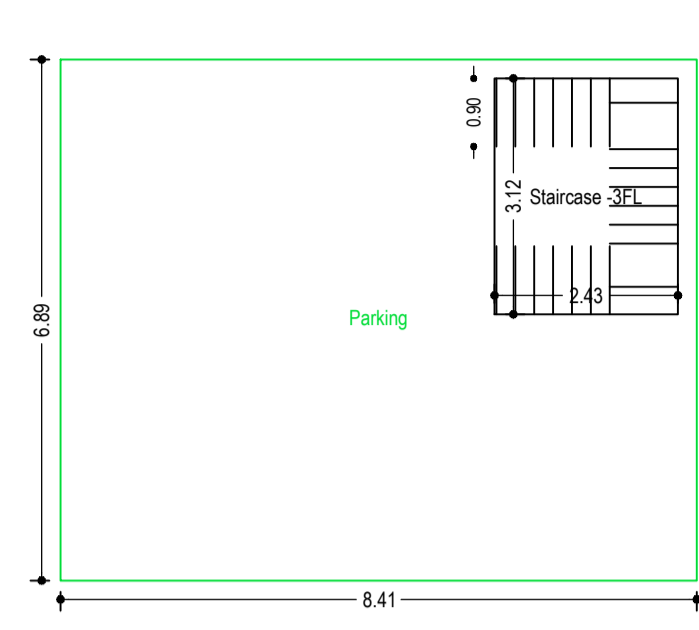
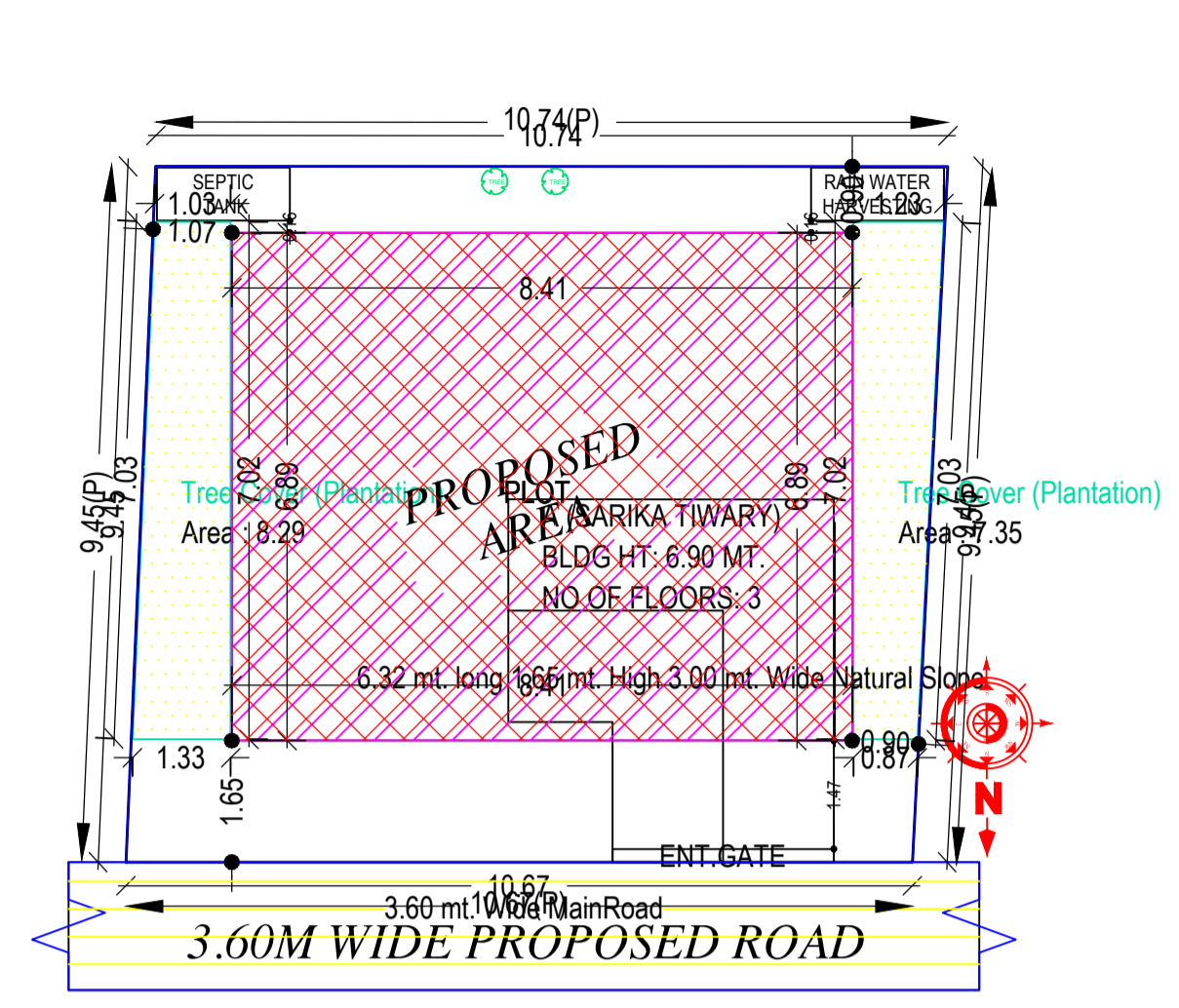
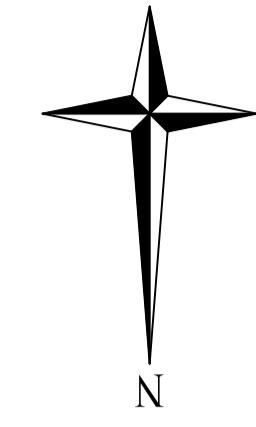

SITE PLAN

SITE PLAN

LOWER GROUND FLOOR PLAN (SCALE 1:100)

GROUND FLOOR PLAN (Proposed) (SCALE 1:100)

FIRST FLOOR PLAN (Proposed) (SCALE 1:100)

TERRACE FLOOR PLAN (SCALE 1:100)

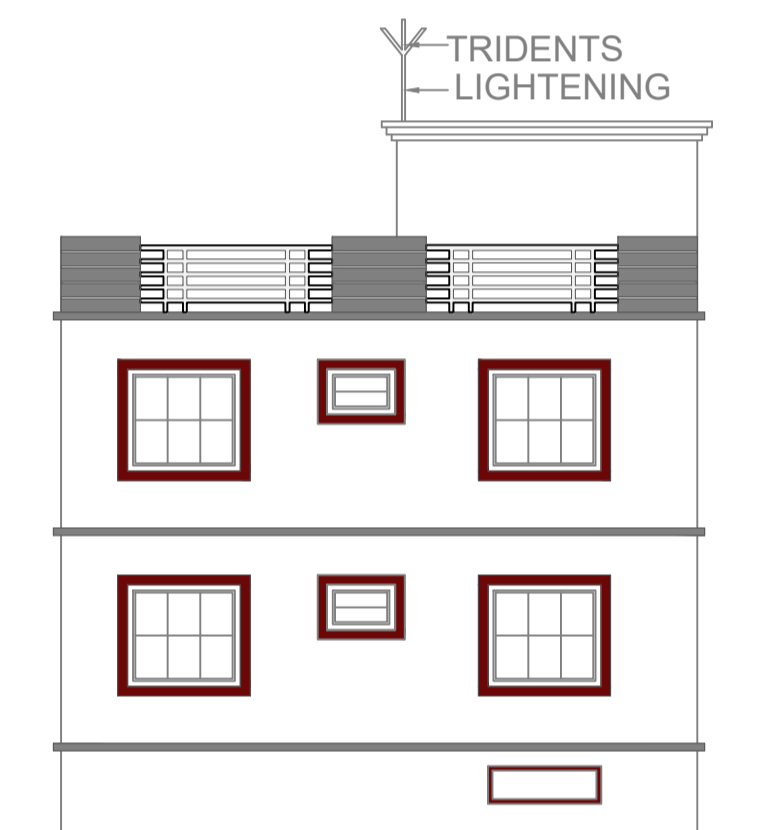

FRONT SIDE ELEVATION

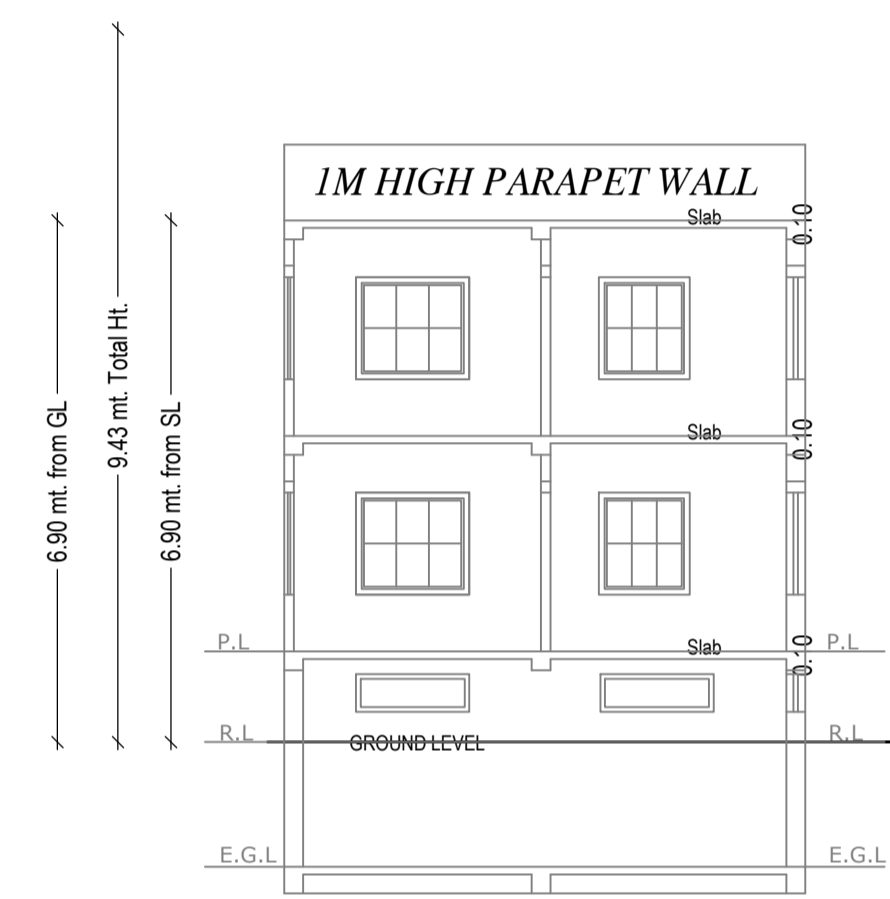

SECTION ON - AA

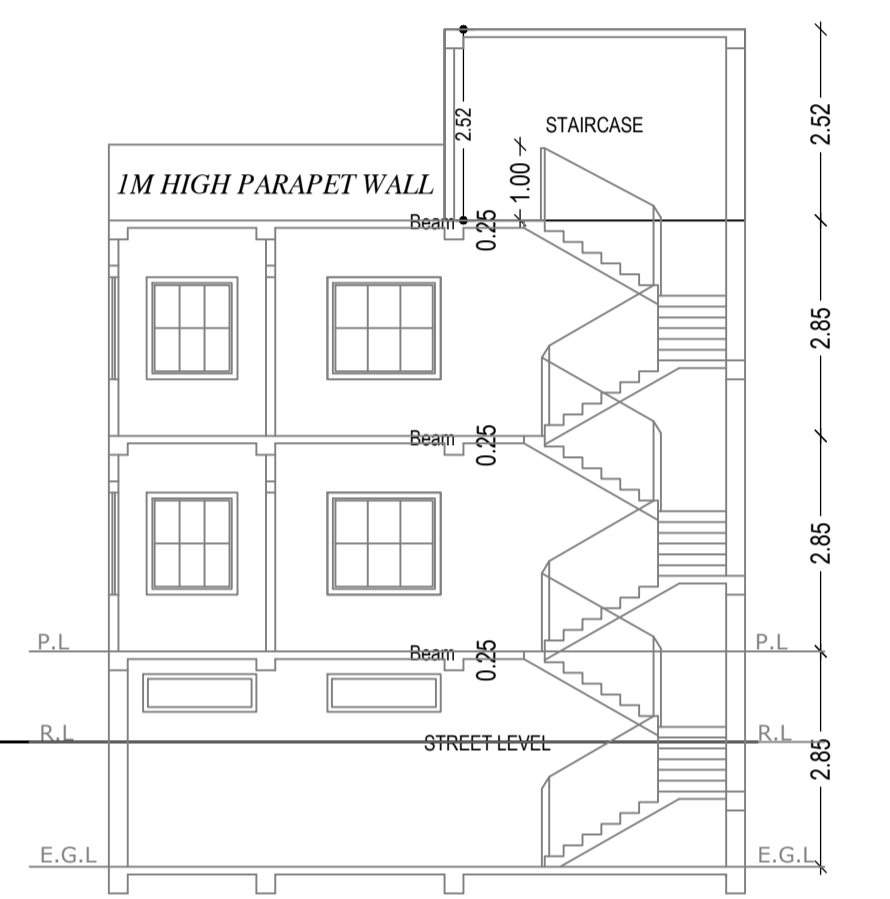

SECTION ON - BB

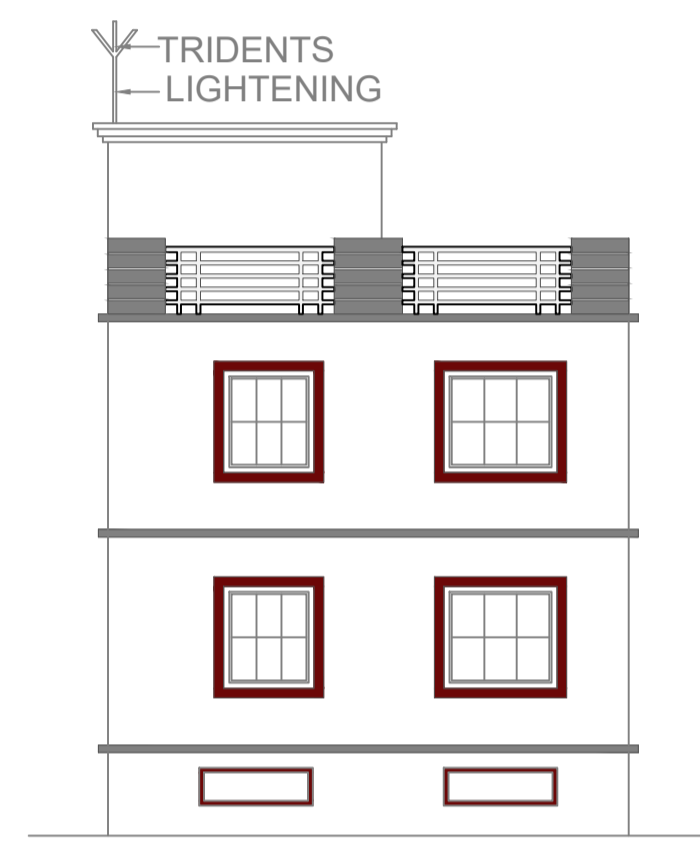

L.H.S. ELEVATION

**CERTIFICATE**  
This is to certify that the structural design of this building will be as per IS 1893-1984 & 4326-1993 to make the same Earth quake resistant.

UnitBUA Table for Building :A (SARIKA TIWARY)

FLOOR	Name	UnitBUA Type	UnitBUA Area	Carpet Area	No. of Rooms	No. of Tenement
FIRST FLOOR PLAN	SPLIT 1	FLAT	0.00	0.00	5	0
GROUND FLOOR PLAN	SPLIT 1	FLAT	97.94	97.65	5	1
Total:	-	-	97.94	97.65	10	1

SCHEDULE OF DOOR:

BUILDING NAME	NAME	LENGTH	HEIGHT	NOS
A (SARIKA TIWARY)	D2	0.75	2.10	02
A (SARIKA TIWARY)	D1	0.90	2.10	02
A (SARIKA TIWARY)	D	1.05	2.10	04

SCHEDULE OF WINDOW/VENTILATION:

BUILDING NAME	NAME	LENGTH	HEIGHT	NOS
A (SARIKA TIWARY)	HLW3	0.90	0.60	02
A (SARIKA TIWARY)	W4	1.20	1.35	04
A (SARIKA TIWARY)	WS	1.50	1.35	10

Building :A (SARIKA TIWARY)

Floor Name	Total Built Up Area (Sq.mt.)	Deductions (Area in Sq.mt.)	Proposed FAR Area (Sq.mt.)	Add Area in FAR (Sq.mt.)	Total FAR Area (Sq.mt.)	Total Consumed Additional FAR Area (Sq.mt.)	Tnmt (No.)
Lower Ground Floor	57.99	50.42	0.00	7.57	7.57	7.57	00
Ground Floor	57.99	0.00	57.99	0.00	57.99	57.99	01
First Floor	57.99	0.00	57.99	0.00	57.99	57.99	00
Terrace Floor	0.00	0.00	0.00	0.00	0.00	0.00	00
Total :	173.97	50.42	115.98	7.57	123.55	123.55	01

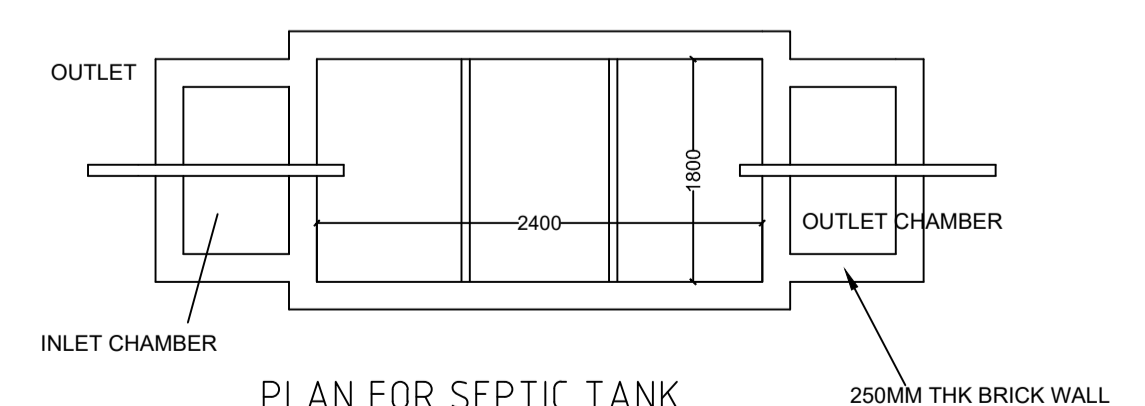

PLAN FOR SEPTIC TANK

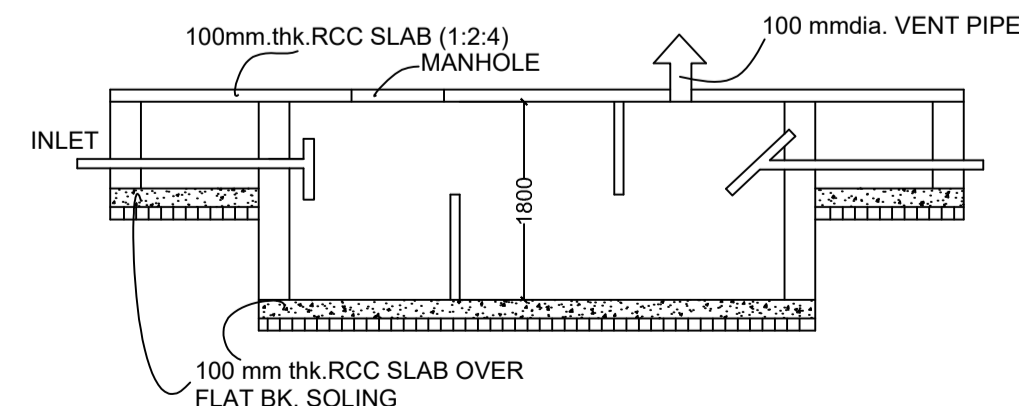

SECTION SCALE 1:50 SEPTIC TANK DETAILS

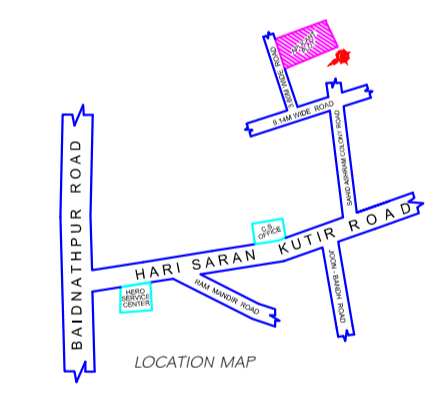

LOCATION MAP

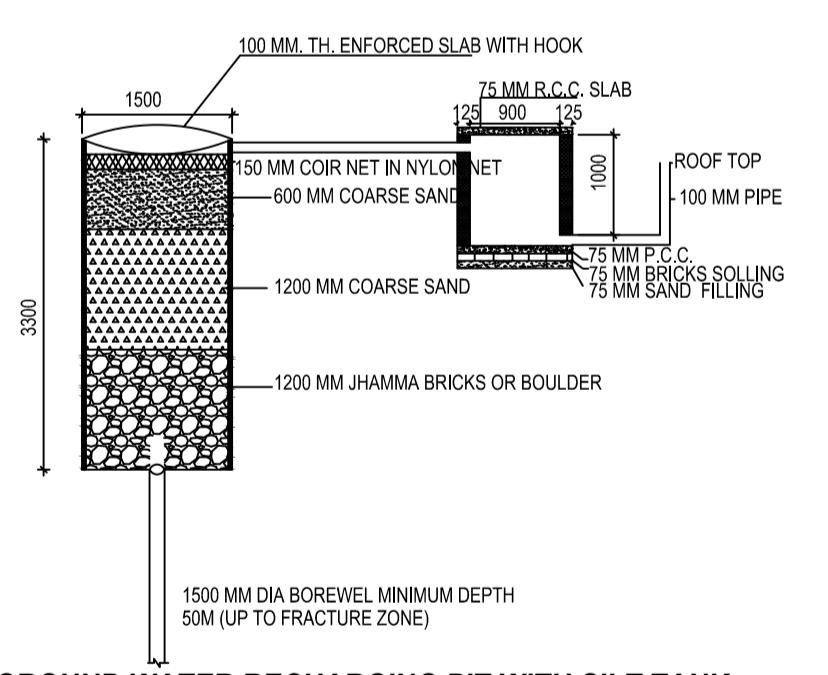

DETAIL OF GROUND WATER RECHARGING PIT WITH SILT TANK SCALE - N.T.S.

AREA STATEMENT		VERSION NO. : 1.0.68
DEOGHAR MUNICIPAL CORPORATION		VERSION DATE: 16/10/2020
PROJECT DETAIL:		
Region: JHARKHAND URBAN	Plot Use: Residential	
LOCAL BODIES	Plot SubUse: Bungalow/ Dwelling / Non Apartment	
District: DEOGHAR	PlotNearbyReligiousStructure: NA	
Authority: DEOGHAR MUNICIPAL CORPORATION	Plot/SubPlot No: T.P.P. NO.- 627	
Inward No: DGMC/BP/0018/W28/2024	North: Road Width - 3.60	
Application Type: General Proposal	South: Plot No. - LAND OF SATYANARAYAN SINGH	
Project Type: Building Permission	East: Plot No. - VENDOR'S LAND SUB PLOT NO. - "2" PART MARK "5"	
Nature of Development: New	West: Plot No. - VENDOR'S LAND SUB PLOT NO. - "2" PART MARK "7"	
Location of Development Area: Old		
AREA DETAILS:		
AREA OF PLOT (Minimum)	(A)	101.05
NET AREA OF PLOT(Gross Plot Area - Deduction from Gross Plot area)	(A-Deductions)	101.05
Deduction for Balance Plot Area(from Gross Plot Area)		
Common Plot		15.64
Total		15.64
BALANCE AREA OF PLOT(Net Plot Area - Recreational/Amenity space)	(A-Deductions)	85.41
PLOT AREA FOR COVERAGE(Net Plot Area)	(A-Deductions)	101.05
Plot Area for FAR (Net Plot Area + RoadWidening Area)	(A-Deductions)	101.05
COVERAGE CHECK		
Permissible Coverage area ( 70.00 % )		70.74
Proposed Coverage Area ( 57.39 % )		57.99
Total Prop. Coverage Area ( 57.39 % )		57.99
Balance coverage area ( 12.62 % )		12.75
FAR CHECK		
Perm. FAR Area ( 1.500 )		151.58
Total Perm. FAR area		151.58
Residential FAR		115.97
Proposed FAR Area		123.54
Total Proposed FAR Area		123.54
Consumed FAR (Factor)		1.22
Balance FAR Area		28.04
BUILT UP AREA CHECK		
Total Proposed BuiltUp Area		173.97
ARCHITECT (Regd)		UJJAWAL KUMAR
ENGINEER (Regd)		
SUPERVISOR (Regd)		
OWNER (Regd)		SARIKA TIWARY
DEVELOPMENT AUTHORITY		LOCAL BODY

COLOR INDEX	
PLOT BOUNDARY	Black
ABUTTING ROAD	Red
PROPOSED CONSTRUCTION	Green
COMMON PLOT	Blue
ROAD WIDENING AREA	Yellow
EXISTING (To be retained)	Orange
EXISTING (To be demolished)	Grey

Buildingwise Floor FAR Details

Floor Name	Building Name A (SARIKA TIWARY)		Total	
	Proposed Built Up Area (Sq.mt.)	Proposed FAR Area (Sq.mt.)	Total Proposed Built Up Area (Sq.mt.)	Total FAR Area (Sq.mt.)
Lower Ground Floor	57.99	7.57	57.99	7.57
Ground Floor	57.99	57.99	57.99	57.99
First Floor	57.99	57.99	57.99	57.99
Terrace Floor	0.00	0.00	0.00	0.00
Total :	173.97	123.55	173.97	123.55

Building USE/SUBUSE Details

Building Name	Building Use	Building SubUse	Building Structure
A (SARIKA TIWARY)	Residential	Bungalow/ Dwelling / Non Apartment	Non-Highrise

FAR & Tenement Details (Table 4c-1)

Building	No. of Same Bldg	Total Built Up Area (Sq.mt.)	Deductions (Area in Sq.mt.)	Proposed FAR Area (Sq.mt.)	Add Area in FAR (Sq.mt.)	Total FAR Area (Sq.mt.)	Total Consumed Additional FAR Area (Sq.mt.)	Tnmt (No.)
A (SARIKA TIWARY)	1	173.97	50.42	115.98	7.57	123.55	123.55	01
Grand Total :	1	173.97	50.42	115.98	7.57	123.55	123.55	01

LTP NAME AND SIGNATURE	STRUCTURAL ENG'S NAME AND SIGNATURE	BUILDER NAME AND SIGNATURE	DIGITAL SIGNATURE
UJJAWAL KUMAR DGMC/ENG/0005/2016			