

Elevation 1 Detail

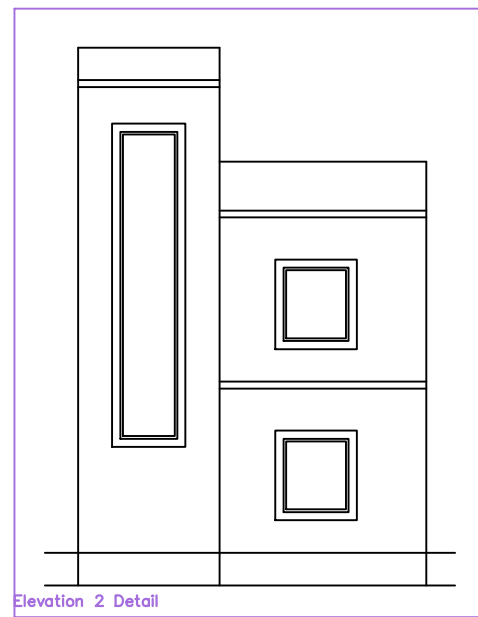

Elevation 2 Detail

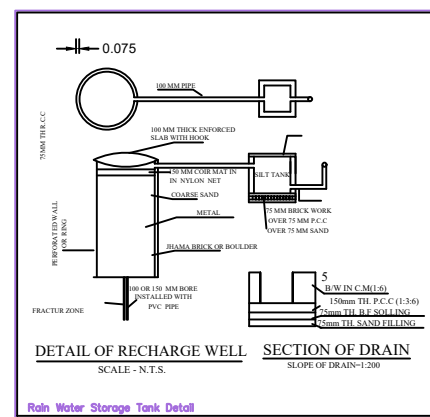

Rain Water Storage Tank Detail

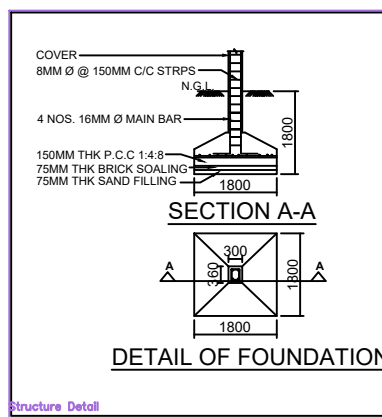

Structure Detail

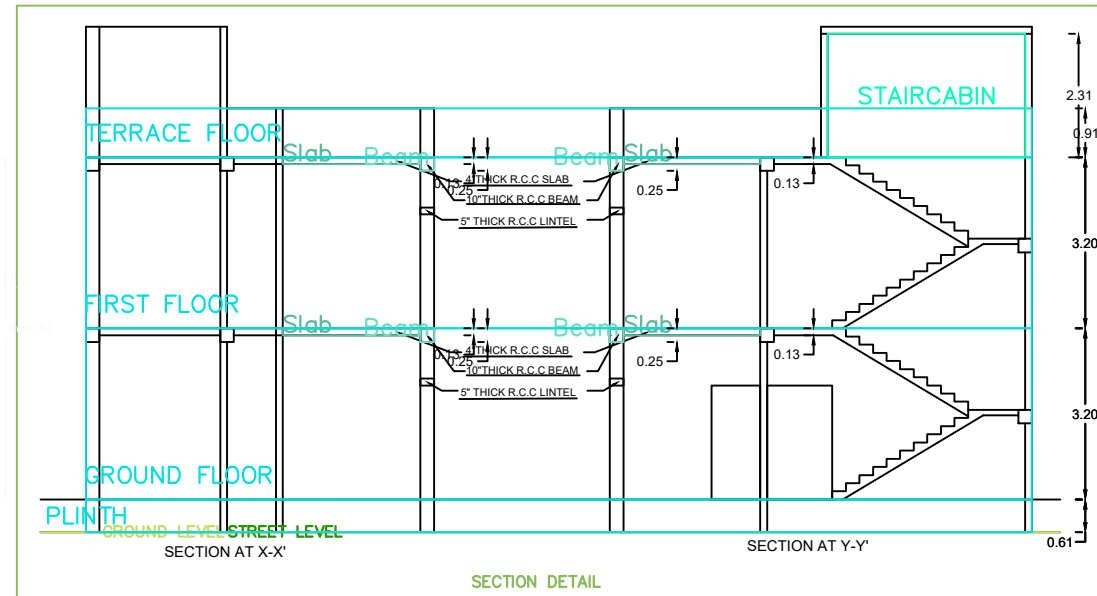

SECTION DETAIL

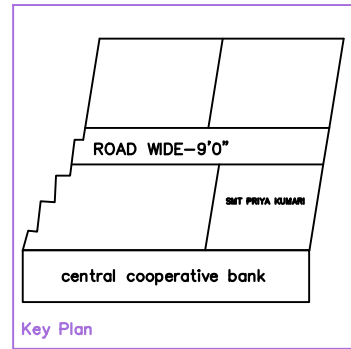

Key Plan

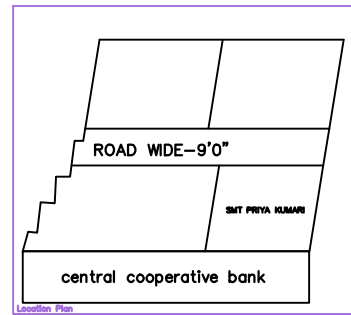

Location Plan

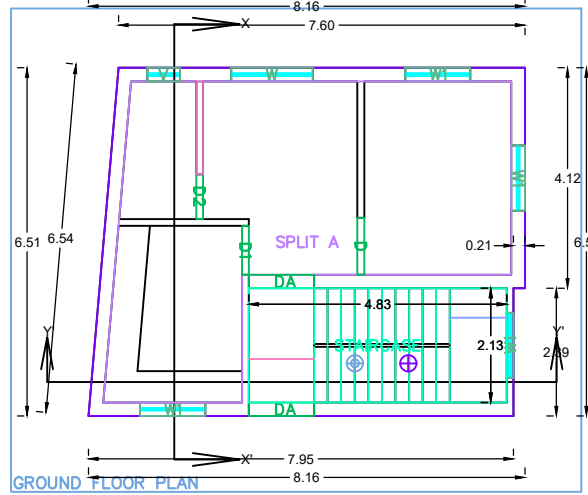

GROUND FLOOR PLAN

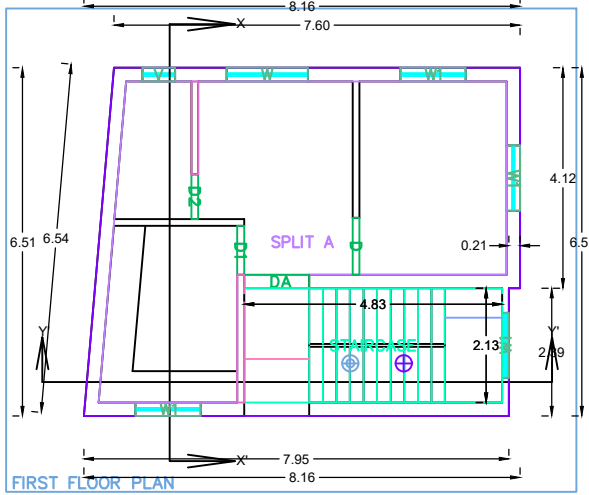

FIRST FLOOR PLAN

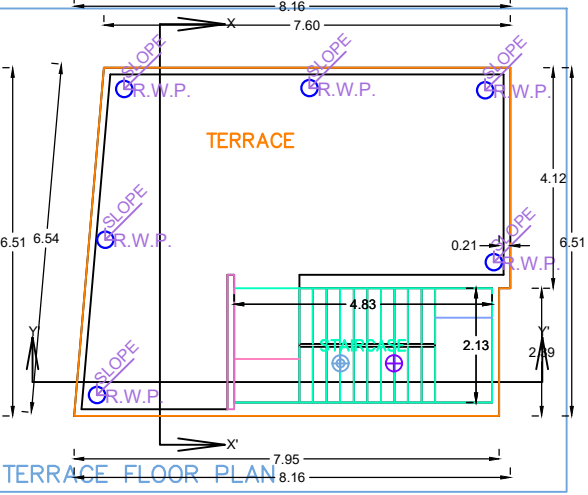

TERRACE FLOOR PLAN



LAND UNDER MOUZA NILKANTHPUR AND NOORPUR NO 415 P.S. DEOGHAR WARD NO. 24 J.B.
NO. 236 T.P. PLOT Q.28 AREA 1500SQFT BELONGS TO SMT MAMATA DEVI D/O SRI KARUNA
SHANKAR MISHRA W/O SRI HITESH CHARANN DWARY OF CHANDRADATT DWARY LANE
DEOGHAR.

SPECIFICATION.

- FOUNDATION:- RCC FOUNDATION AS SHON IN DRAWING
- FLOOR:- VIRIFIED TILES AS APPROVED
- D.P.C.:25MM THK DAMP PROFF COUSE AT PLINTH LEVEL (DR. FIXIT 200g in 50 KG CEMENT)
- LINTEL:-150MM THK RCC LINTEL (1:2:4)
- ROOF:-100MM THK OR AS SHOWN IN DRG.RCC SLAB (M-20)
- WALL:-150MM THK 1st CLASS BRICKWORK IN CM (1:6)
- PLASTER :-12MM THK CEMENT PLASTER IN CM (1:6) INTERNAL & EXTERNAL SURFACE OF THE WALL & 10MM THK PLASTER IN (1:4) FOR CEILING
- DOOR:- COMMERCIAL FLUSH DOOR WITH SAL WOOD DOOR FRAM
- WINDOW :-STELL WINDOW WITH GLASS
- SWERAGE :- THROUGH SEPTIC TANK
- ELECTRICAL:- CONCEALED WIRING WITH COPPER CONDUCTOR
- WATER SUPPLY:- THROUGH BORE WELL WITH O.H TANK
- EXTERNAL FINISHING - SNOWCEM
- INTERNAL FINISHING -> OLD BOND DISTEMPER OVER P.O.P
- GRADE OF CONCRETE SHALL BEAM-20
- ALL CONCRETE SHALL BE MACHINE MIXED AND MACHINE VIBRATED

AREA STATEMENT

CATEGORY	EXISTING	REQUIREMENT	REMARKS
GROUND FL.	1057.50 Sqft	00.00 Sqft	EXIST
1ST FL.	1057.50 Sqft	000 Sqft	EXIST
TOTAL	2114.00 Sqft	0000 Sqft	EXIST
TOTAL BUILT UP AREA =		2114.00 Sqft	
TOTAL PLOT AREA (AS PER SITE) =		1500.00 Sqft	
F A R = 0.00			

SCHEDULE OF DOORS \$ WINDOWS

SL NO.	PARTICULAR	SYMBOL	SIZE	REMARKS
01.	DOORS	D	3'-6" X 7'-0"	SINGLE PANEL
		D1	3'-0" X 7'-0"	SINGLE PANEL
		D2	2'-9" X 7'-0"	SINGLE PANEL
	D3	2'-6" X 7'-0"	SINGLE PANEL	
02.	WINDOWS	W	5'-0" X 4'-6"	GLAZED
		W1	4'-0" X 4'-6"	GLAZED
		W2	3'-0" X 3'-6"	GLAZED
		V	2'-6" X 2'-0"	

OWNER SIGN.	LICENCED ENGG SIGN