

SPECIFICATION OF DRAIN	
1.	FOUNDATION.
2.	SAND FILLING.
3.	BRICK SOLLING.
4.	P.C.C (1: 4: 8).
5.	B/W IN C.M (1:6)..
6.	R.C.C (1:1.5: 3) COVER SLAB.

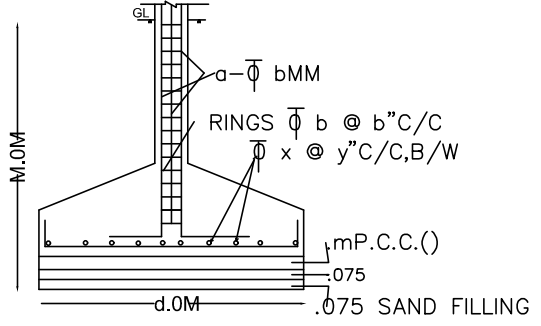

SECTION ON A-A
SCALE= 1:50

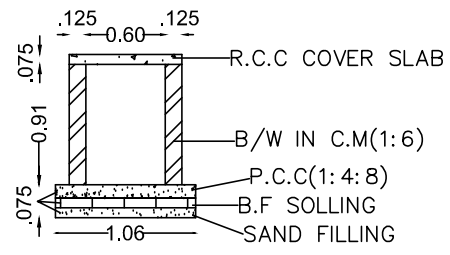

SECTION OF DRAIN
SLOPE OF DRAIN=1:200

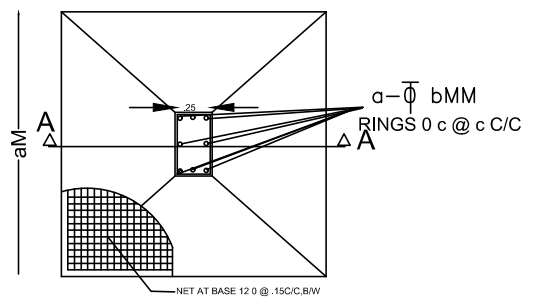

PLAN OF COLUMN FOUNDATION
SCALE= 1: 50

1. D.P.C 1:2:4 +2 / CICO.
2. COLUMN & FOOTING R.C.C (1:1.5:3).
3. BEAMS, SLAB & LINTEL R.C.C(1:1.5:3:)
4. WALLS: - BRICKWORK IN C.M 1:6.
5. WINDOWS: - FULLY GLAZED STEEL CASEMENT.
6. DOORS: - 35MM TH. FLUSH DOORS.
7. PLASTER: - 1/2" TH. PLASTER ON WALL 1:6.
8. WALL FINISH : - DRY DISTEMPER ON INSIDE
9. FLOORING: - vitrified/ceramic tiles.
10. WIRING: - CONCEALED COPPER WIRING.

Structure Detail