

### INDEX

(W)	WET RISER CUM DOWN COME.
(H)	HYDRANT OUT LET.
(T)	HOSE REEL HOSE.
(ω)	FIRE CELL POINT.
(H)	HOOTER
(@)	DELIVERY HOSE BOX
(F)	F.S. IN LET
(S/A)	AREA PROTECTED WITH SMOKE DETECTORS WITH CONTROL PANEL
(S)	AREA PROTECTED WITH AUTO Matic SPRINGE BOX.

### DOOR WINDOW SCHEDULE

TYPE	WIDTH	HT.	SILL	DESCRIPTION
D1	0.76	2.13	0.00	STEEL FRAME FLUSH DOOR
D2	0.91	2.13	0.00	STEEL FRAME FLUSH DOOR
D3	.99	2.13	0.00	STEEL FRAME FLUSH DOOR
D4	1.05	2.13	0.00	STEEL FRAME FLUSH DOOR
W1	0.76	.60	1.53	STEEL FRAME GLAZED SHUTTER
W2	.99	1.23	0.90	STEEL FRAME GLAZED SHUTTER
W3	1.20	1.23	0.90	STEEL FRAME GLAZED SHUTTER
W4.	1.50	1.23	0.90	STEEL FRAME GLAZED SHUTTER

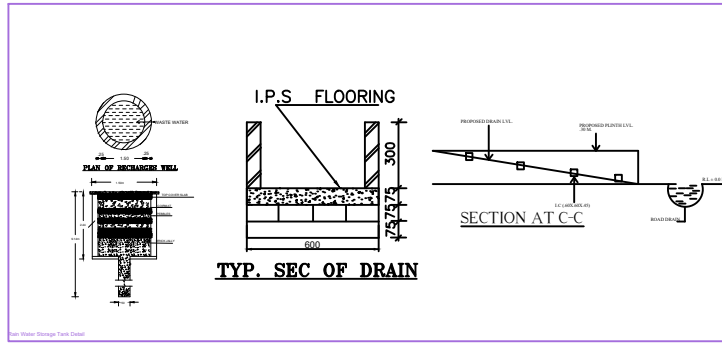
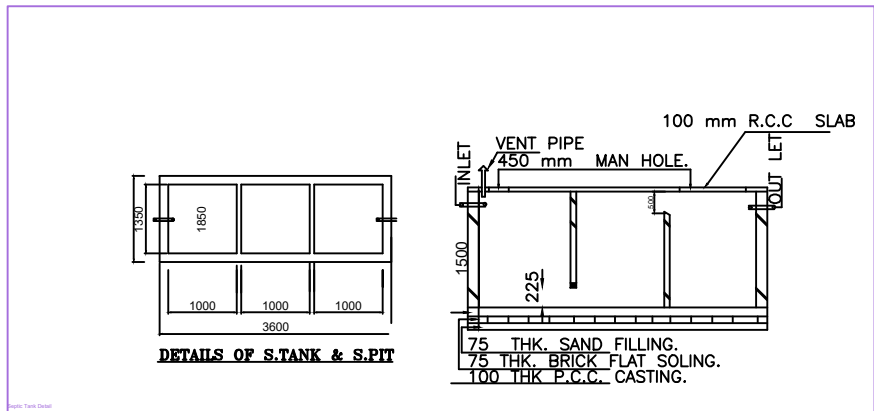
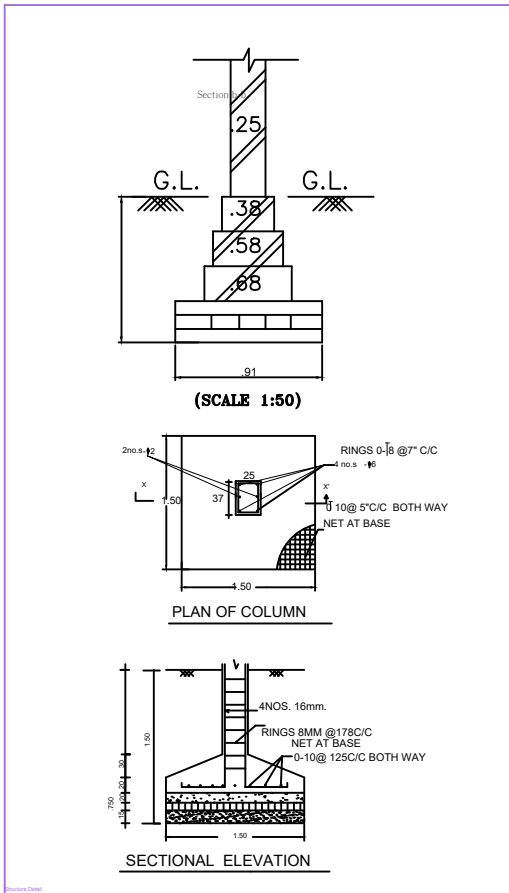
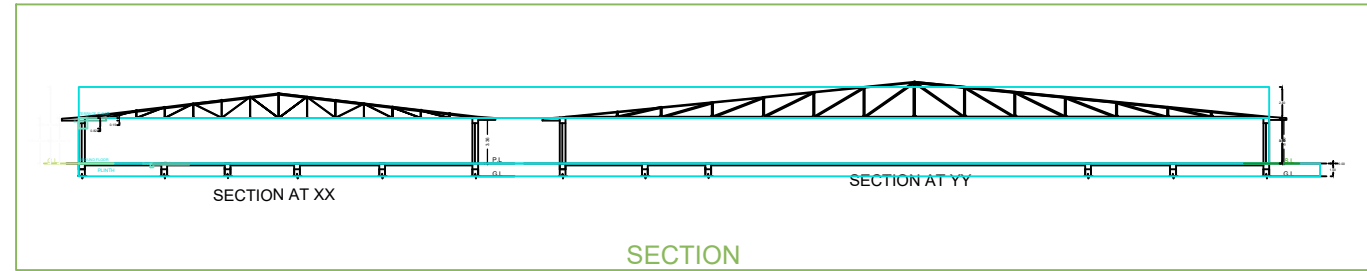

Architect's Signature. Applicant's Signature.

Blank space for signatures.