

Proposal Basic Information

Proposal File No.	PZZ/BP/0010/2021
Owner Name	ATAULA ANSARI
Khata No	14
Plot No	112
Village Name	BARA
Use	Residential
SubUse	Bungalow/ Dwelling / Non Apartment

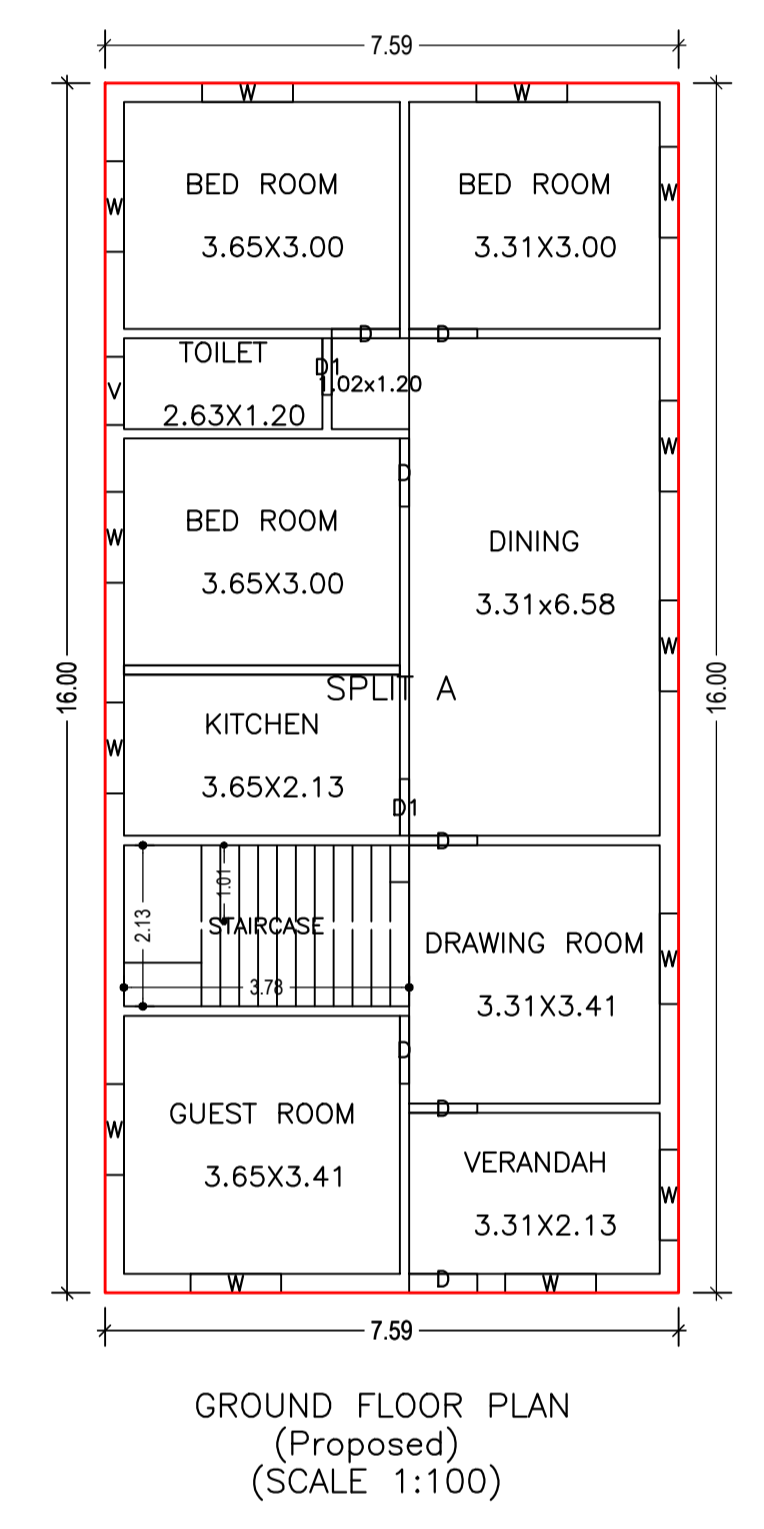
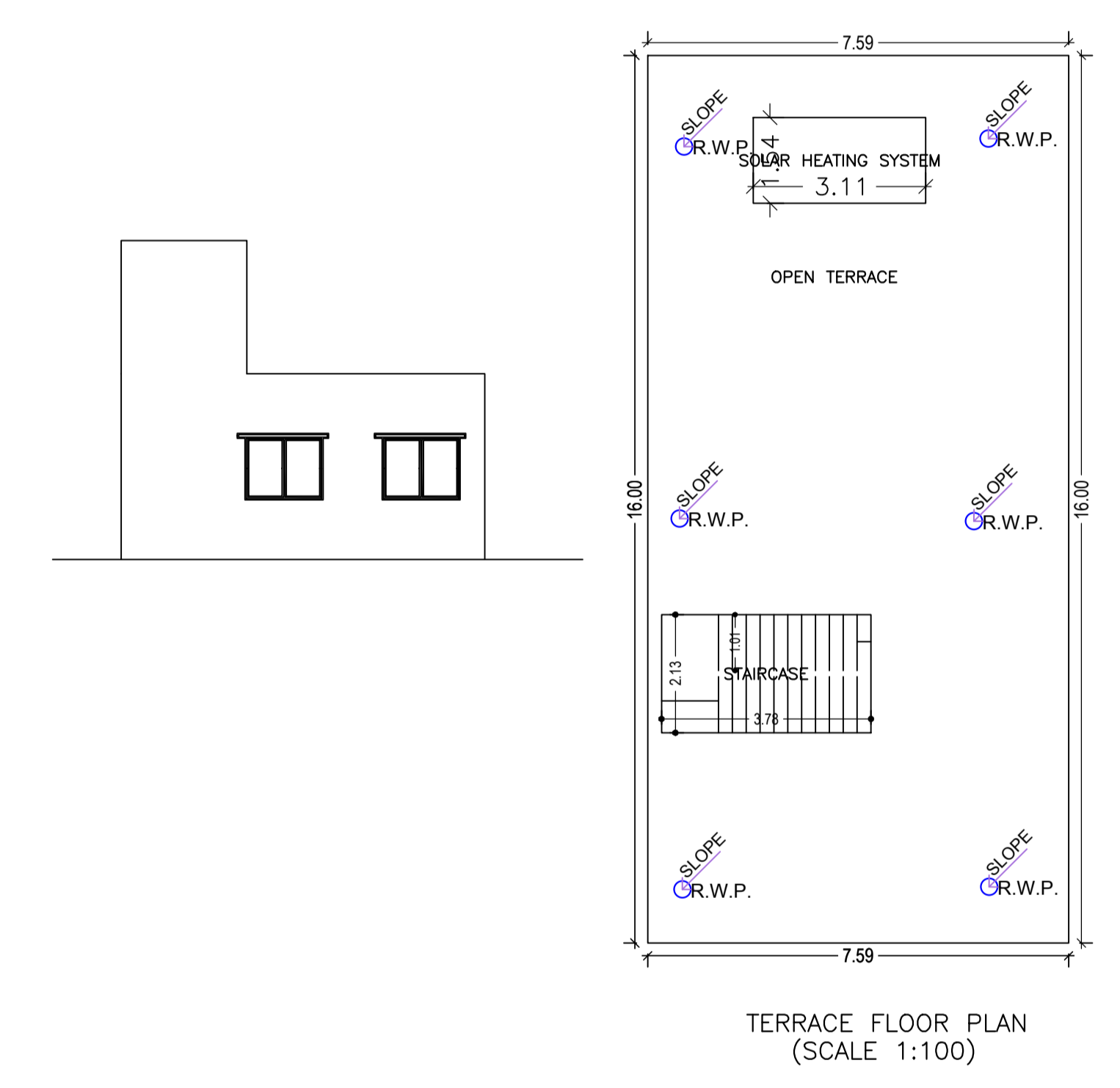
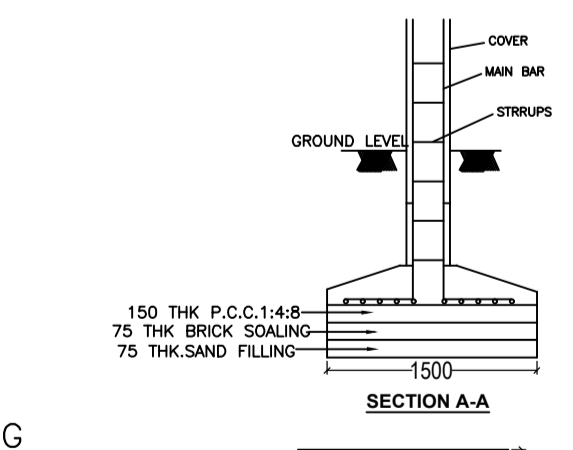
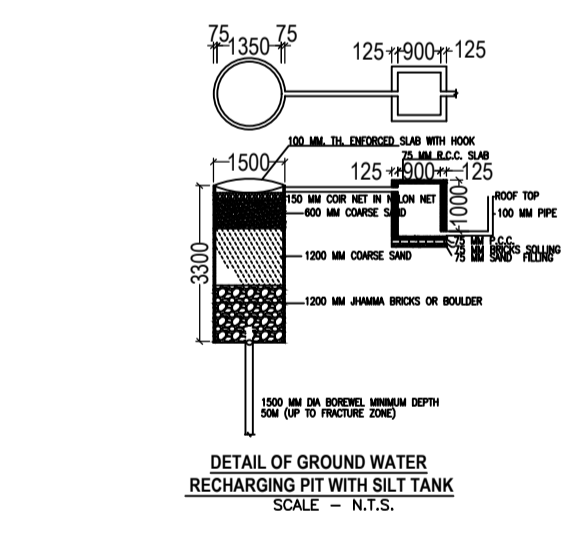
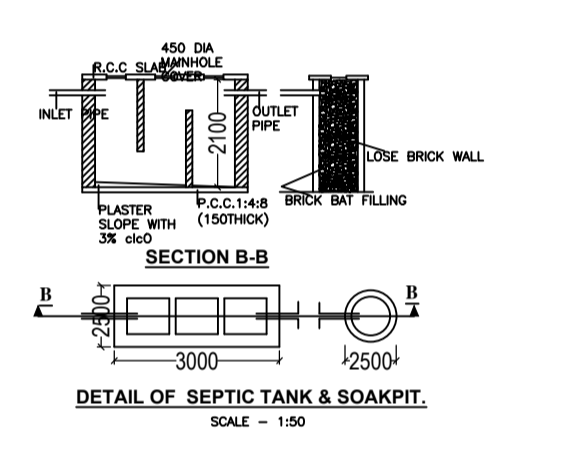
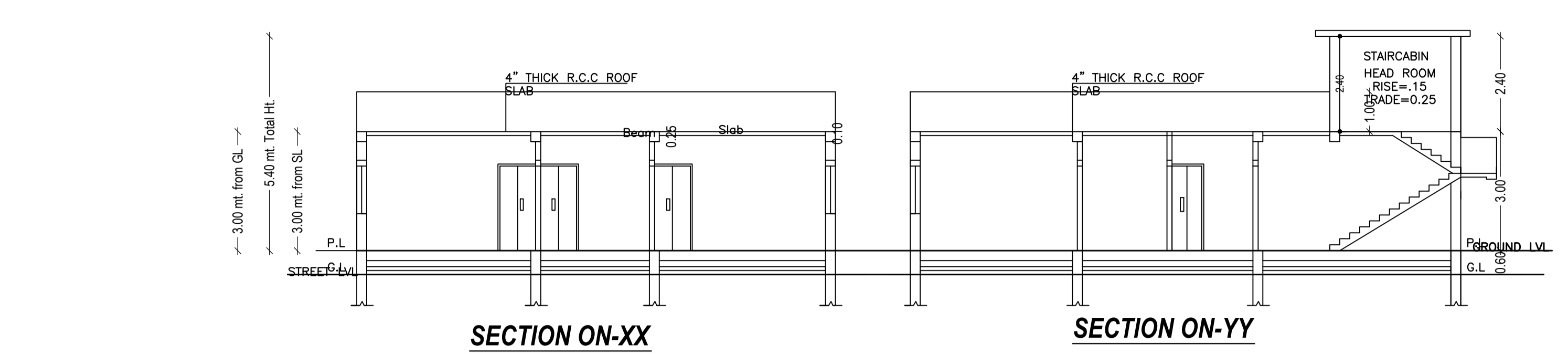
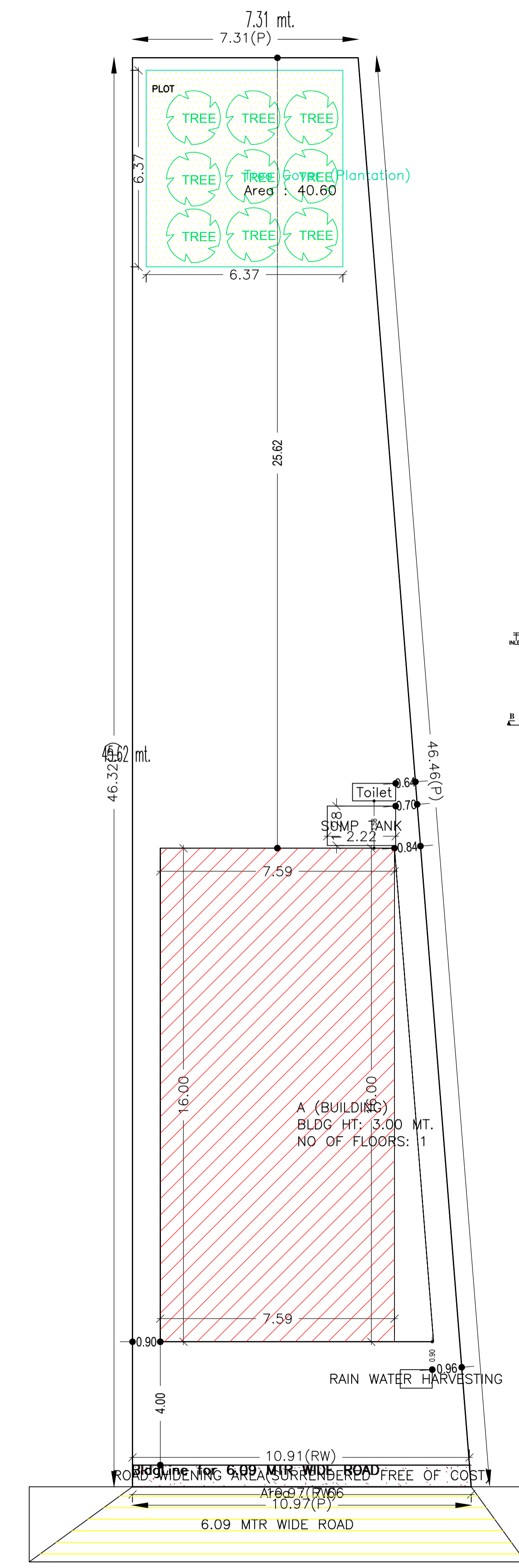

Building USE/SUBUSE Details

Building Name	Building Use	Building SubUse	Building Structure
A (BUILDING)	Residential	Bungalow/ Dwelling / Non Apartment	Non-Highrise

COLOR INDEX

PLOT BOUNDARY	Black
ABUTTING ROAD	Green
PROPOSED CONSTRUCTION	Red
COMMON PLOT	Yellow
ROAD WIDENING AREA	Blue
EXISTING (To be retained)	Light Blue
EXISTING (To be demolished)	Dark Blue

SCHEDULE OF DOOR:

BUILDING NAME	NAME	LENGTH	HEIGHT	NOS
A (BUILDING)	D1	0.75	2.10	02
A (BUILDING)	D	0.90	2.10	07

SCHEDULE OF WINDOW/VENTILATION:

BUILDING NAME	NAME	LENGTH	HEIGHT	NOS
A (BUILDING)	V	0.90	0.60	01
A (BUILDING)	W	1.20	1.20	13

FAR & Tenement Details (Table 4c-1)

Building	No. of Same Bldg	Total Built Up Area (Sq.mt.)	Proposed FAR Area (Sq.mt.) Resi.	Total FAR Area (Sq.mt.)	Total Consumed Additional FAR Area (Sq.mt.)	Tnmt (No.)
A (BUILDING)	1	121.39	121.39	121.39	121.39	01
Grand Total :	1	121.39	121.39	121.39	121.39	01

AREA STATEMENT PALAMU ZILA PARISHAD

VERSION NO.: 1.0.60
VERSION DATE: 16/10/2020

Region	Plot Use
JHARKHAND URBAN	Residential
LOCAL BODIES	Bungalow/ Dwelling / Non Apartment
District: PALAMU	Plot Nearby/Religious Structure: NA
Authority: PALAMU ZILA PARISHAD	Plot/SubPlot No: 112
Inward No: PZZ/BP/0010/2021	North: -
Application Type: General Proposal	South: -
Project Type: Building Permission	East: -
Nature of Development: New	West: -
Location of Development Area: Old Area	

AREA DETAILS:

AREA OF PLOT (Minimum)	(A)	SQ.MT.
423.36		423.36
Deduction for NetPlot Area		
Surrender Free of Cost		7.66
Total		7.66
NET AREA OF PLOT(Gross Plot Area - Deduction from Gross Plot area)	(A-Deductions)	415.71
Deduction for Balance Plot Area(from Gross Plot Area)		
Surrender Free of Cost		7.66
Common Plot		40.60
Total		48.25
BALANCE AREA OF PLOT(Net Plot Area - Recreational/Amenity space)	(A-Deductions)	375.11
PLOT AREA FOR COVERAGE(Net Plot Area)	(A-Deductions)	415.71
Plot Area for FAR (Net Plot Area + RoadWidening Area)	(A-Deductions)	423.36

COVERAGE CHECK

Permissible Coverage area (60.00 %)	
249.43	
Proposed Coverage Area (29.20 %)	
121.39	
Total Prop. Coverage Area (29.2 %)	
121.39	
Balance coverage area (30.80 %)	
128.04	

FAR CHECK

Perm. FAR Area (2.00)	
846.72	
Total Perm. FAR area	
846.72	
Residential FAR	
121.39	
Proposed FAR Area	
121.39	
Total Proposed FAR Area	
121.39	
Consumed FAR (Factor)	
0.29	
Balance FAR Area	
725.33	

BUILT UP AREA CHECK

Total Proposed BuiltUp Area	
121.39	

ARCHITECT (Regd) MOHAMMAD FAIZ KHAN
ENGINEER (Regd)
SUPERVISOR (Regd)
OWNER (Regd) ATAULA ANSARI

DEVELOPMENT AUTHORITY LOCAL BODY

Building :A (BUILDING)

Floor Name	Total Built Up Area (Sq.mt.)	Proposed FAR Area (Sq.mt.) Resi.	Total FAR Area (Sq.mt.)	Total Consumed Additional FAR Area (Sq.mt.)	Tnmt (No.)
Ground Floor	121.39	121.39	121.39	121.39	01
Terrace Floor	0.00	0.00	0.00	0.00	00
Total :	121.39	121.39	121.39	121.39	01
Total Number of Same Buildings	1				
Total :	121.39	121.39	121.39	121.39	01

UnitBUA Table for Building :A (BUILDING)

FLOOR	Name	UnitBUA Type	UnitBUA Area	Carpet Area	No. of Rooms	No. of Tenement
GROUND FLOOR	SPLIT A	FLAT	112.82	112.36	9	1
Total:	-	-	112.82	112.36	9	1

Buildingwise Floor FAR Details

Floor Name	Building Name A (BUILDING)		Total	
	Proposed Built Up Area (Sq.mt.)	Proposed FAR Area (Sq.mt.)	Total Proposed Built Up Area (Sq.mt.)	Total FAR Area (Sq.mt.)
Ground Floor	121.39	121.39	121.39	121.39
Terrace Floor	0.00	0.00	0.00	0.00
Total :	121.39	121.39	121.39	121.39

LTP NAME AND SIGNATURE	STRUCTURAL ENG'S NAME AND SIGNATURE	BUILDER NAME AND SIGNATURE	DIGITAL SIGNATURE
MOHAMMAD FAIZ KHAN PZZ/ENG/0006/2019			