

SITE PLAN

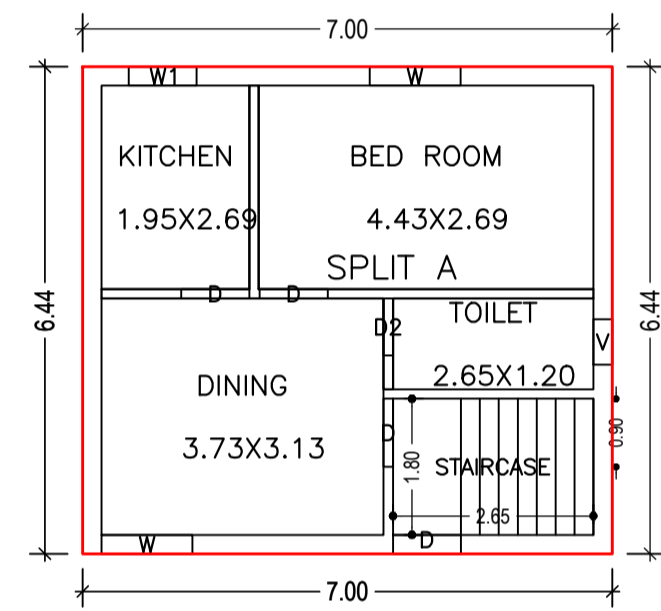

GROUND FLOOR PLAN (Proposed) (SCALE 1:100)

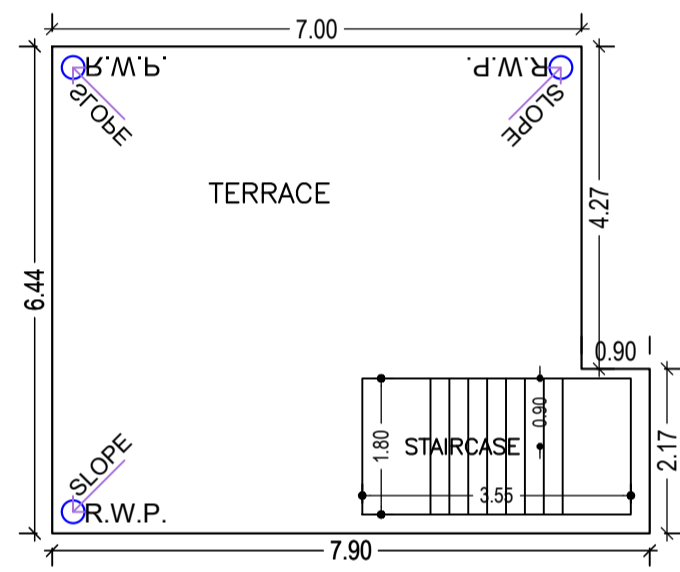

TERRACE FLOOR PLAN (SCALE 1:100)

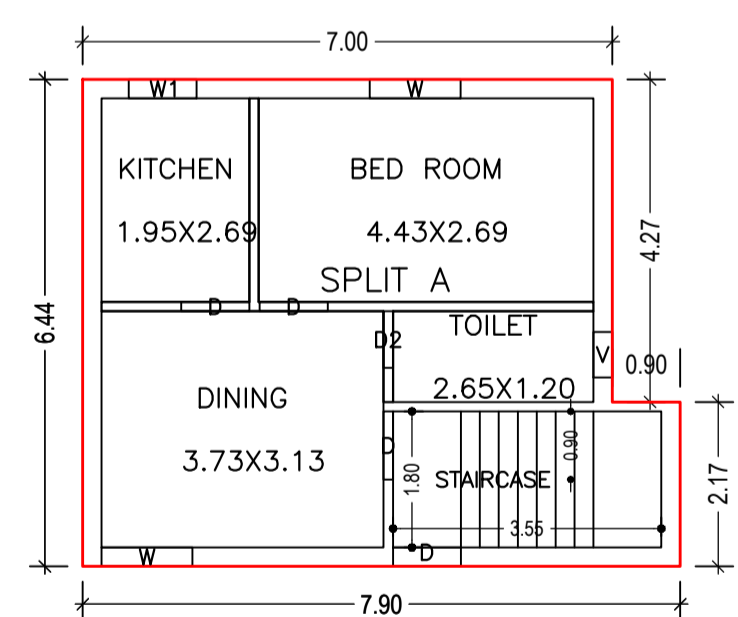

FIRST FLOOR PLAN (Proposed) (SCALE 1:100)

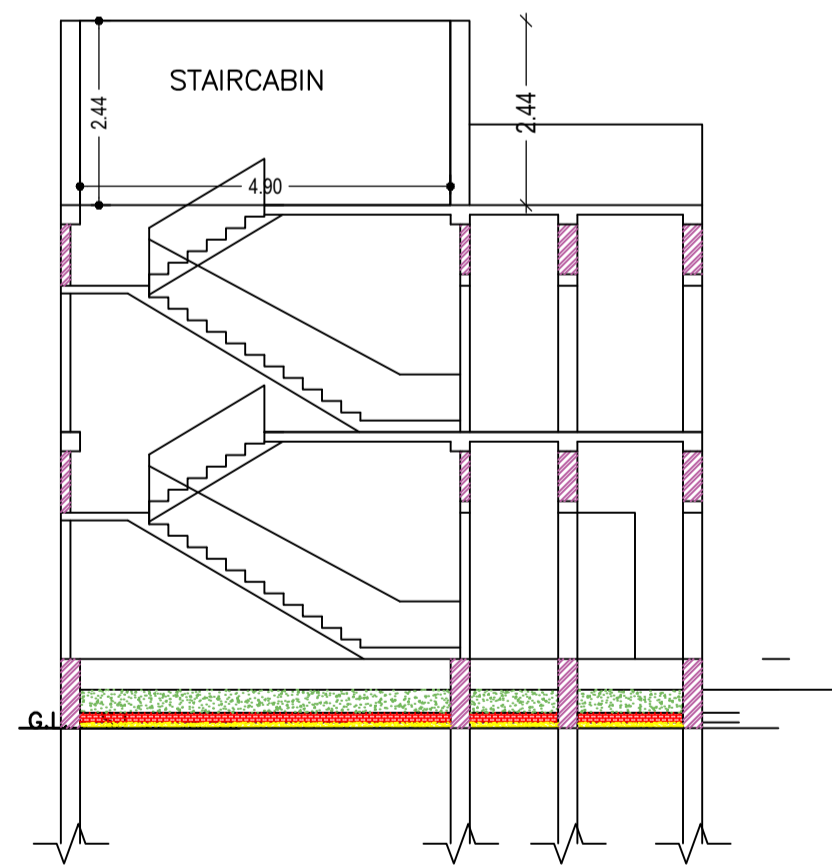

CROSS SECTION (A)

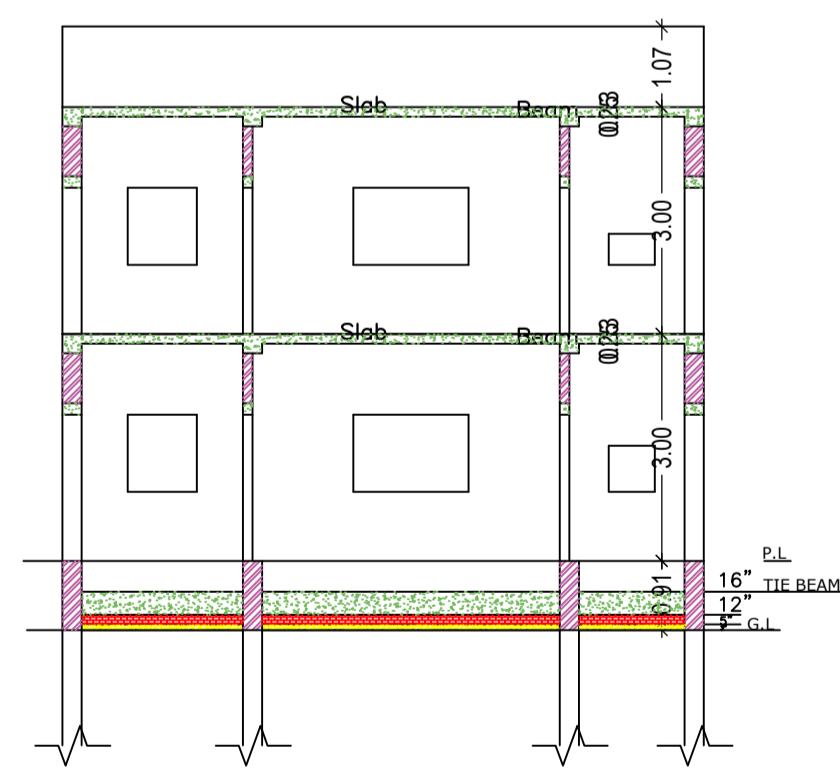

CROSS SECTION (B)

Floor Name	Total Built Up Area (Sq.mt.)	Proposed FAR Area (Sq.mt.)	Total FAR Area (Sq.mt.)	Total Consumed Additional FAR Area (Sq.mt.)	Tnmt (No.)
Ground Floor	45.11	45.11	45.11	45.11	01
First Floor	47.07	47.07	47.07	47.07	00
Terrace Floor	0.00	0.00	0.00	0.00	00
Total :	92.18	92.18	92.18	92.18	01
Total Number of Same Buildings	1				
Total :	92.18	92.18	92.18	92.18	01

SCHEDULE OF DOOR:

BUILDING NAME	NAME	LENGTH	HEIGHT	NOS
A (RESIDENTIAL)	D2	0.75	2.10	02
A (RESIDENTIAL)	D	0.90	2.10	06

SCHEDULE OF WINDOW/VENTILATION:

BUILDING NAME	NAME	LENGTH	HEIGHT	NOS
A (RESIDENTIAL)	V	0.60	0.90	02
A (RESIDENTIAL)	W1	0.90	1.20	02
A (RESIDENTIAL)	W	1.20	1.20	04

UnitBUA Table for Building :A (RESIDENTIAL)

FLOOR	Name	UnitBUA Type	UnitBUA Area	Carpet Area	No. of Rooms	No. of Tenement
GROUND FLOOR PLAN	SPLIT A	FLAT	66.60	64.00	4	1
FIRST FLOOR PLAN	SPLIT A	FLAT	0.00	0.00	4	0
Total:	-	-	66.60	64.00	8	1

FAR & Tenement Details (Table 4c-1)

Building	No. of Same Bldg	Total Built Up Area (Sq.mt.)	Proposed FAR Area (Sq.mt.)	Total FAR Area (Sq.mt.)	Total Consumed Additional FAR Area (Sq.mt.)	Tnmt (No.)
A (RESIDENTIAL)	1	92.18	92.18	92.18	92.18	01
Grand Total :	1	92.18	92.18	92.18	92.18	01

Proposal Basic Information

Proposal File No.	PZP/BI/0025/2022
Owner Name	Nisha Devi
Khata No	44
Plot No	44
Village Name	VILLAGE NAME
Use	Residential
SubUse	Bungalow/ Dwelling / Non Apartment

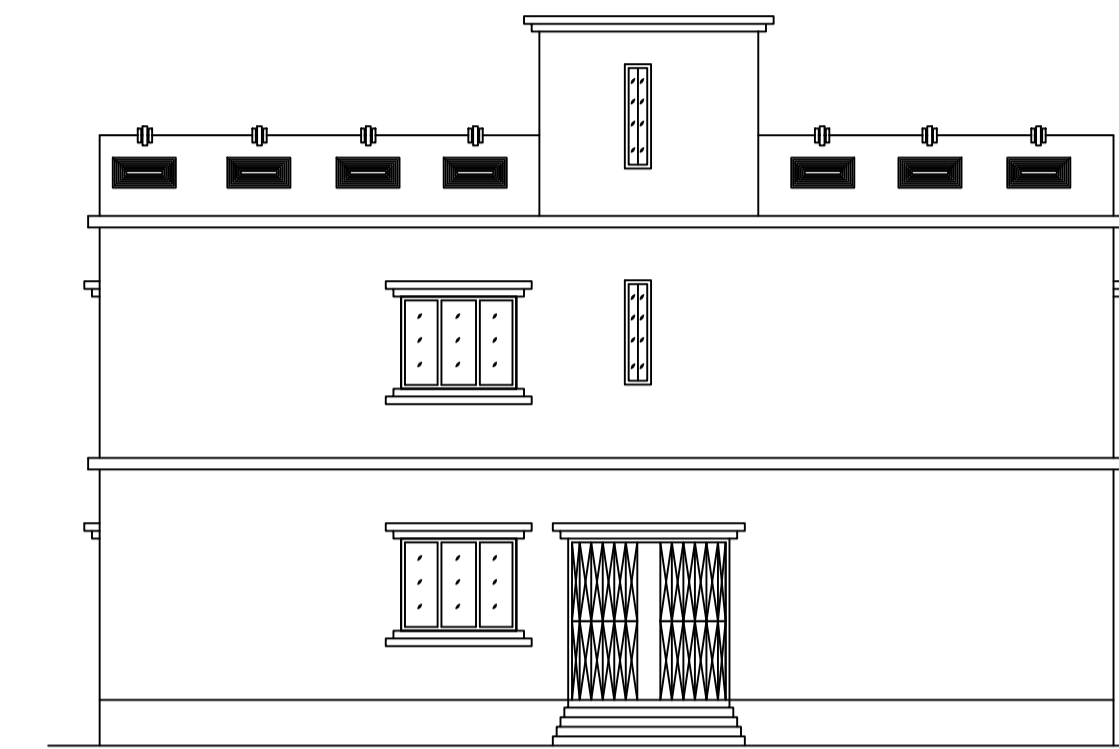

CROSS ELEVATION

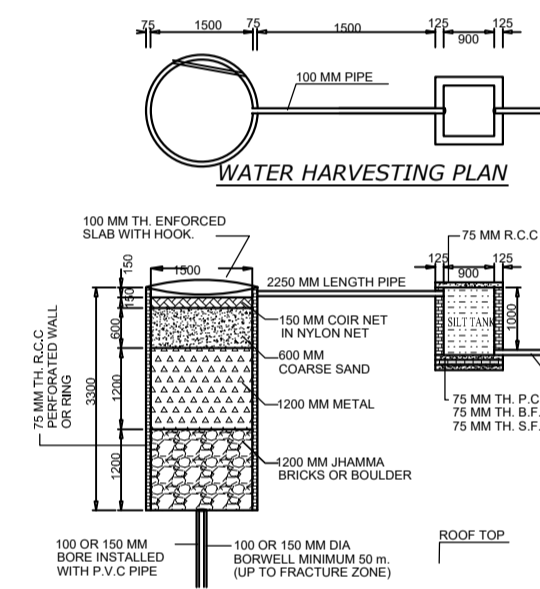

WATER HARVESTING PLAN

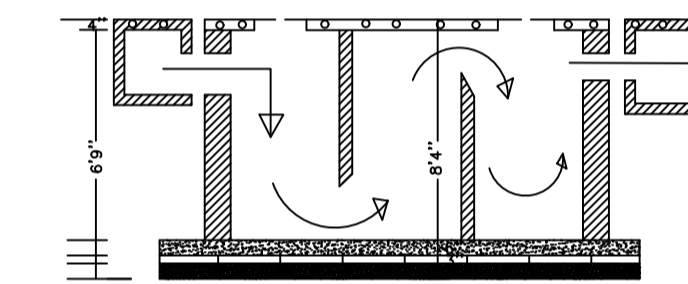

SECTION

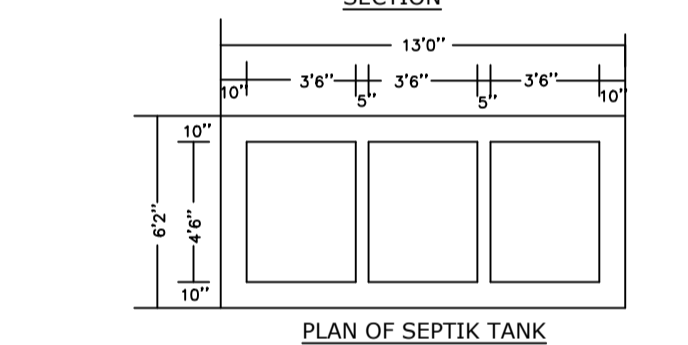

PLAN OF SEPTIC TANK

AREA STATEMENT PALAMU ZILA PARISHAD		VERSION NO. : 1.0.62
PROJECT DETAIL:		VERSION DATE: 16/10/2020
Region: JHARKHAND URBAN LOCAL BODIES	Plot Use: Residential	
District: PALAMU	Plot SubUse: Bungalow/ Dwelling / Non Apartment	
Authority: PALAMU ZILA PARISHAD	PlotNearby/ReligiousStructure: NA	
Inward_No: PZP/BI/0025/2022	PlotSubPlot No: 44	
Application Type: General Proposal	North: -	
Project Type: Building Permission	South: -	
Nature of Development: New	East: -	
Location of Development Area: Old Area	West: -	
AREA DETAILS:		SQ.MT.
AREA OF PLOT (Minimum)	(A)	80.87
Deduction for NetPlot Area		
Surrender Free of Cost		8.06
Total		8.06
NET AREA OF PLOT(Gross Plot Area - Deduction from Gross Plot area)	(A-Deductions)	72.80
Deduction for Balance Plot Area(from Gross Plot Area)		
Surrender Free of Cost		8.06
Common Plot		7.13
Total		15.20
BALANCE AREA OF PLOT(Net Plot Area - Recreational/Amenity space)	(A-Deductions)	65.67
PLOT AREA FOR COVERAGE(Net Plot Area)	(A-Deductions)	72.80
Plot Area for FAR (Net Plot Area + RoadWidening Area)	(A-Deductions)	80.87
COVERAGE CHECK		
Permissible Coverage area (70.00 %)		50.96
Proposed Coverage Area (61.96 %)		45.11
Total Prop. Coverage Area (61.96 %)		45.11
Balance coverage area (8.04 %)		5.85
FAR CHECK		
Perm. FAR Area (2.00)		161.74
Total Perm. FAR area		161.74
Residential FAR		92.18
Proposed FAR Area		92.18
Total Proposed FAR Area		92.18
Consumed FAR (Factor)		1.14
Balance FAR Area		69.56
BUILT UP AREA CHECK		
Total Proposed BuiltUp Area		92.18
ARCHITECT (Regd)	RANJIT KUMAR	
ENGINEER (Regd)		
SUPERVISOR (Regd)		
OWNER (Regd)	Nisha Devi	
DEVELOPMENT AUTHORITY	LOCAL BODY	

COLOR INDEX	
PLOT BOUNDARY	Black
ABUTTING ROAD	Green
PROPOSED CONSTRUCTION	Red
COMMON PLOT	Yellow
ROAD WIDENING AREA	Blue
EXISTING (To be retained)	Light Blue
EXISTING (To be demolished)	Light Yellow

Buildingwise Floor FAR Details

Floor Name	Building Name A (RESIDENTIAL)		Total	
	Proposed Built Up Area (Sq.mt.)	Proposed FAR Area (Sq.mt.)	Total Proposed Built Up Area (Sq.mt.)	Total FAR Area (Sq.mt.)
Ground Floor	45.11	45.11	45.11	45.11
First Floor	47.07	47.07	47.07	47.07
Terrace Floor	0.00	0.00	0.00	0.00
Total :	92.18	92.18	92.18	92.18

Building USE/SUBUSE Details

Building Name	Building Use	Building SubUse	Building Structure
A (RESIDENTIAL)	Residential	Bungalow/ Dwelling / Non Apartment	Non-Highrise

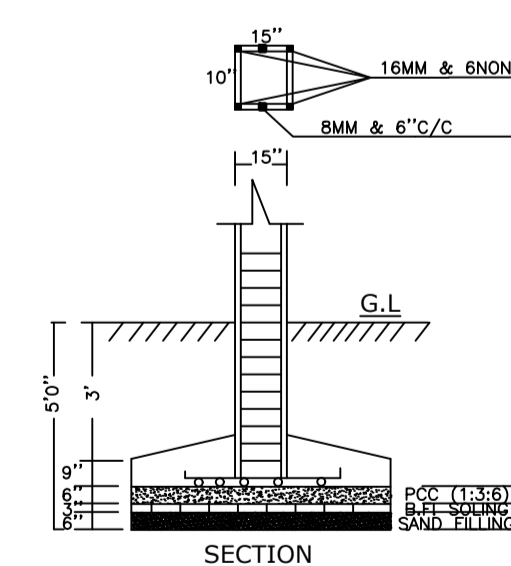

SECTION

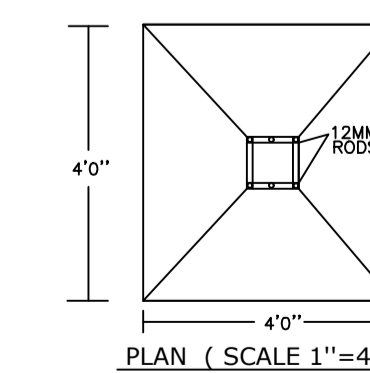

PLAN (SCALE 1"=4")



FRONT ELEVATION

LTP NAME AND SIGNATURE	STRUCTURAL ENG'S NAME AND SIGNATURE	BUILDER NAME AND SIGNATURE	DIGITAL SIGNATURE
RANJIT KUMAR PZP/ENG/0002/2018			