

Project Title :RESIDENTIAL APARTMENT

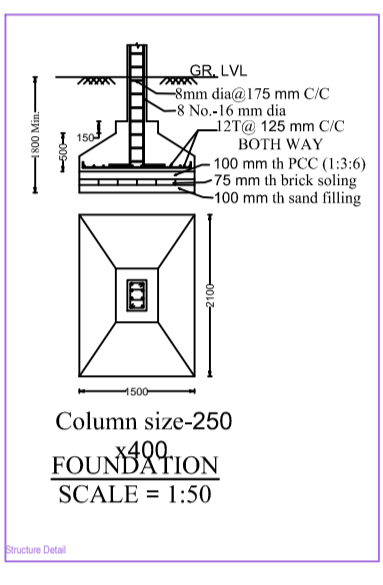
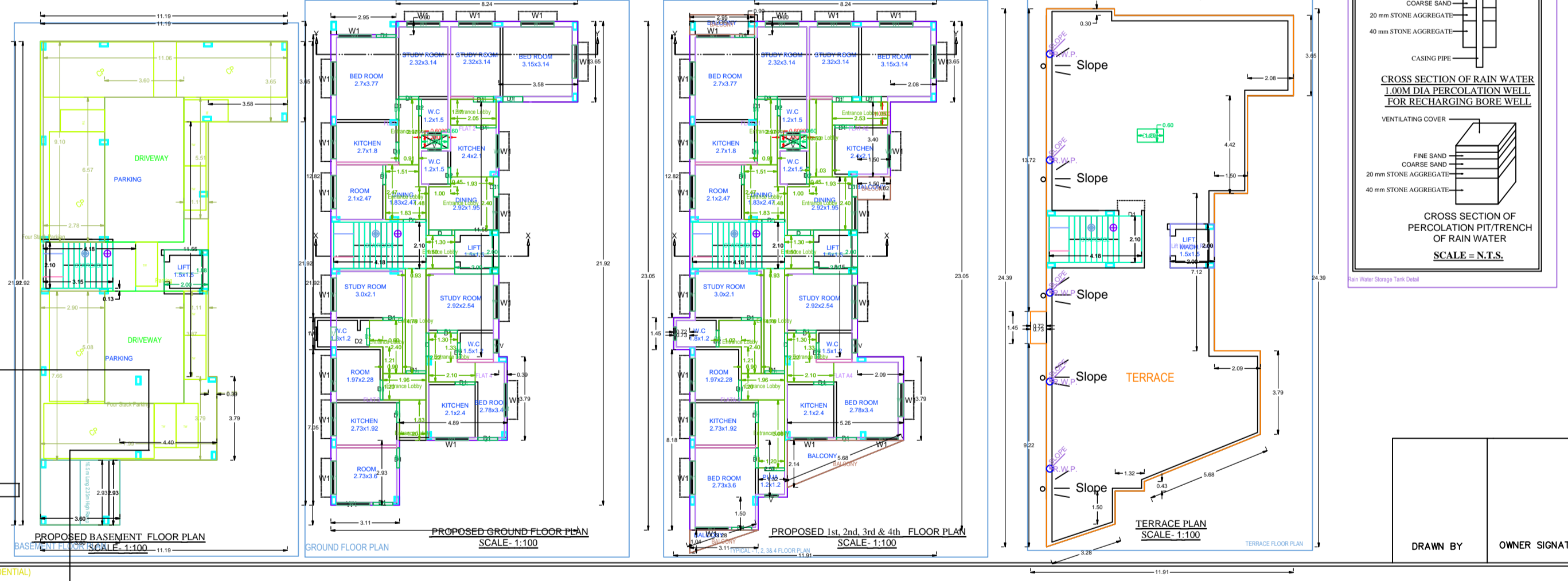
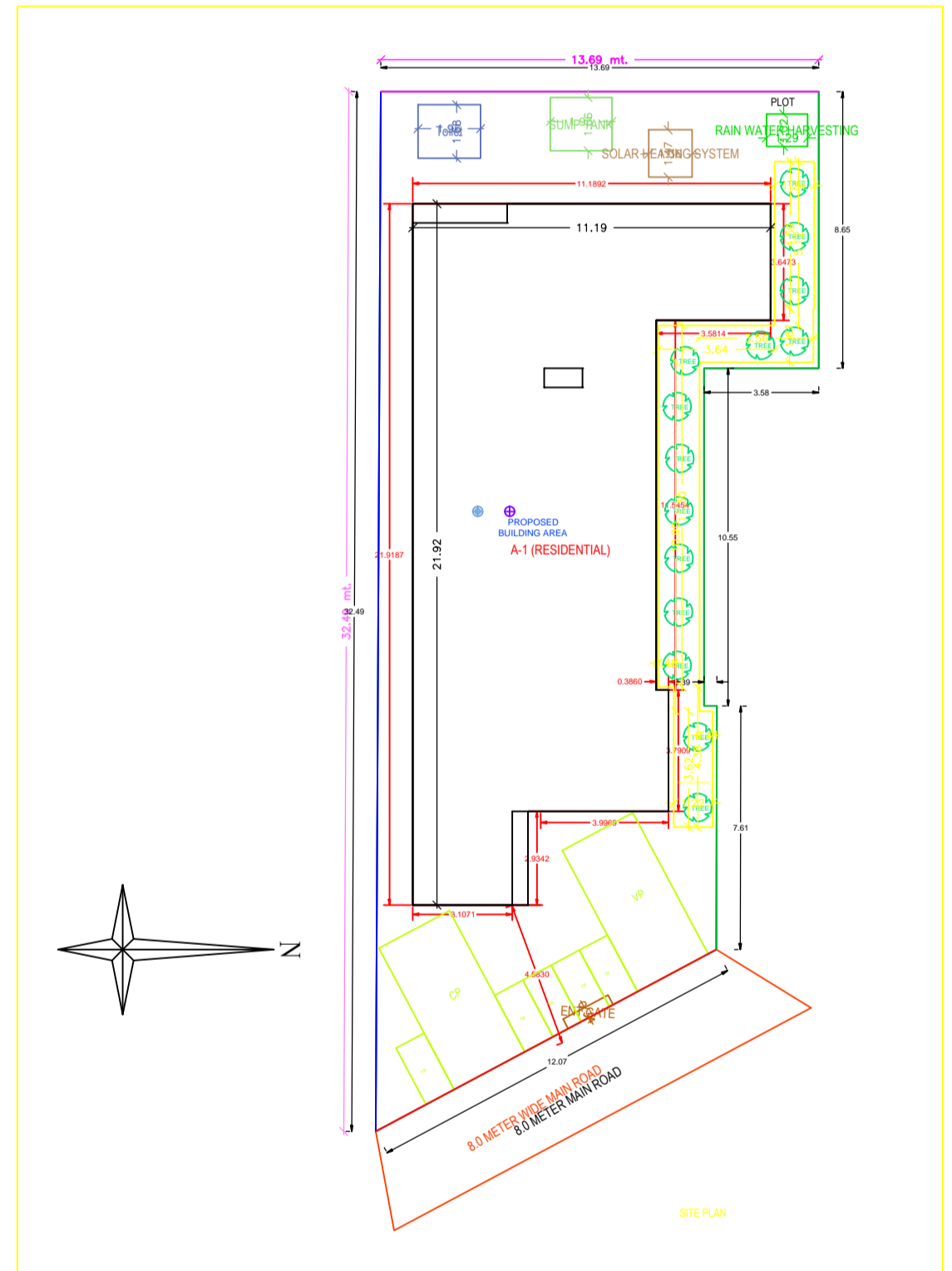
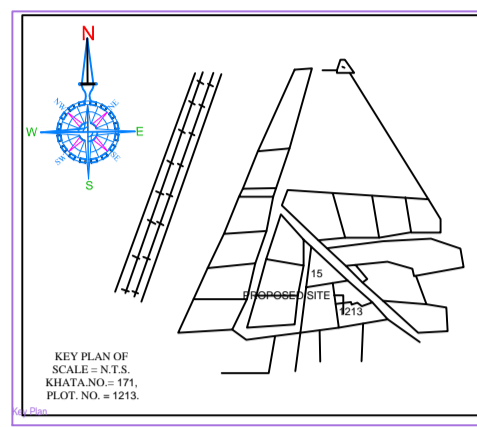
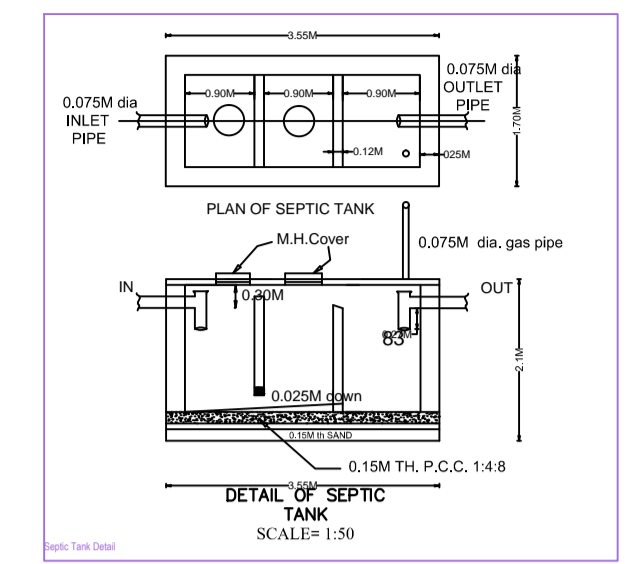
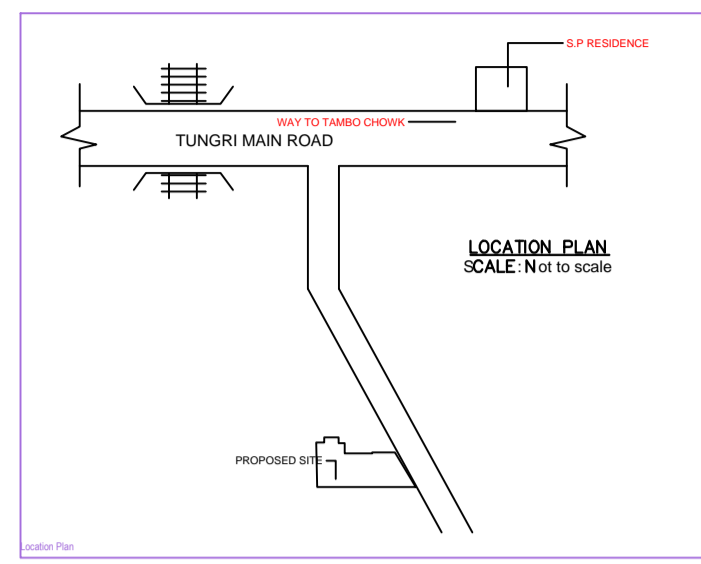
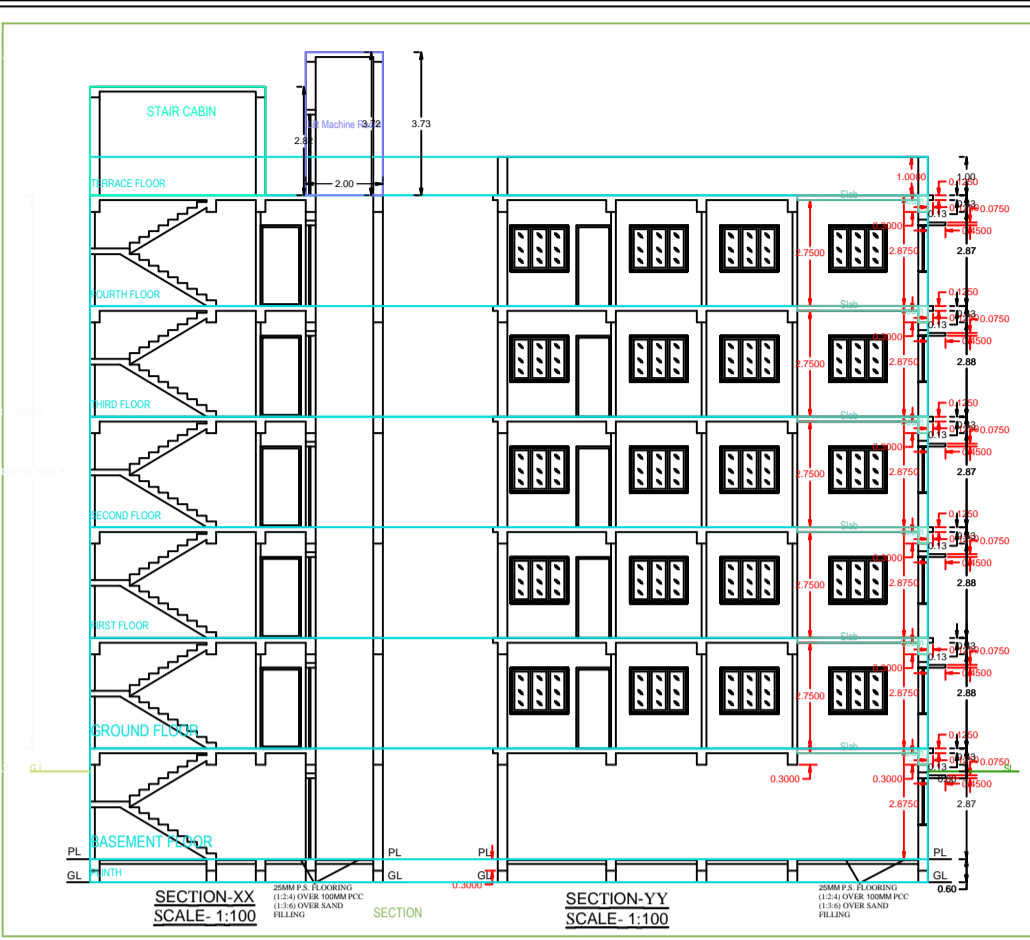

**ARCHITECTURAL SPECIFICATION:**

- FOUNDATION: 60 diameter up to 90 dia. except otherwise stated.
- FOUNDATION: 1:1.5 cement concrete for footing over RCC mat of 140 dia.
- SUPERSTRUCTURE: 1:1.5 RCC column with backwork with cement sand mortar 1:6 for 0.25M, black wall & 1:3 for 0.15M, black wall.
- DAMP PROOF COURSE: 40mm. black CC (1:1.2:4) with suitable water proofing compound.
- PLASTER: 12mm. TO 20 mm. black cement & sand (1:1).
- FLOORING: 25 mm. thick IPS flooring over 100 mm. black RCC and over 90mm. black RCC slab.
- TOILET: W.C. & E.W.C. with standard fittings.
- DOOR: 60 x 1.2M x 2.1M. DO 60M x 2.1M. DO 40-95M x 2.1M. DO 40M x 2.1M.
- WINDOW: W1: 1.2M x 1.2M. W2: 1.0M x 1.2M. W3: 0.8M x 0.45M.
- VENTILATOR: V: 0.6M x 0.45M.

PROPOSED RESIDENTIAL BUILDING (G.O. No. 14, 2nd, 3rd & 4th FLOOR PLAN TO BE CONSTRUCTED BY M. N. V. P. PARMAM, S/O. M. N. V. P. PARMAM, PLOT No. 111, KHATA No. 111, MATTA-BARABHATI, KOLHAPUR, WEST SINGHBHURM ZILA PARISHAD.

AREA STATEMENT	WEST SINGHBHURM ZILA PARISHAD	SECTION NO. 13.17
Project No.	RESIDENTIAL/2023/0000	
Project Name	Plot No. Residential	
Project Location	Plot No. Residential	
Project Type	General Proposal	
Project Category	Residential	
Project Status	Under Review	
Project Date	2023-07-01	
Project No.	RESIDENTIAL/2023/0000	
Project Name	Plot No. Residential	
Project Location	Plot No. Residential	
Project Type	General Proposal	
Project Category	Residential	
Project Status	Under Review	
Project Date	2023-07-01	
Project No.	RESIDENTIAL/2023/0000	
Project Name	Plot No. Residential	
Project Location	Plot No. Residential	
Project Type	General Proposal	
Project Category	Residential	
Project Status	Under Review	
Project Date	2023-07-01	
Project No.	RESIDENTIAL/2023/0000	
Project Name	Plot No. Residential	
Project Location	Plot No. Residential	
Project Type	General Proposal	
Project Category	Residential	
Project Status	Under Review	
Project Date	2023-07-01	

Color	Index
Red	Proposed
Green	Existing
Blue	Proposed
Yellow	Existing

Category	Area (Sq. M)
Proposed	1112.22
Existing	0.00
Total	1112.22

Category	Area (Sq. M)
Proposed	1112.22
Existing	0.00
Total	1112.22

Category	Area (Sq. M)
Proposed	1112.22
Existing	0.00
Total	1112.22

Category	Area (Sq. M)
Proposed	1112.22
Existing	0.00
Total	1112.22

Category	Area (Sq. M)
Proposed	1112.22
Existing	0.00
Total	1112.22

Category	Area (Sq. M)
Proposed	1112.22
Existing	0.00
Total	1112.22

Category	Area (Sq. M)
Proposed	1112.22
Existing	0.00
Total	1112.22

Category	Area (Sq. M)
Proposed	1112.22
Existing	0.00
Total	1112.22

Category	Area (Sq. M)
Proposed	1112.22
Existing	0.00
Total	1112.22

Category	Area (Sq. M)
Proposed	1112.22
Existing	0.00
Total	1112.22

Category	Area (Sq. M)
Proposed	1112.22
Existing	0.00
Total	1112.22

Category	Area (Sq. M)
Proposed	1112.22
Existing	0.00
Total	1112.22

Category	Area (Sq. M)
Proposed	1112.22
Existing	0.00
Total	1112.22