

SITE PLAN

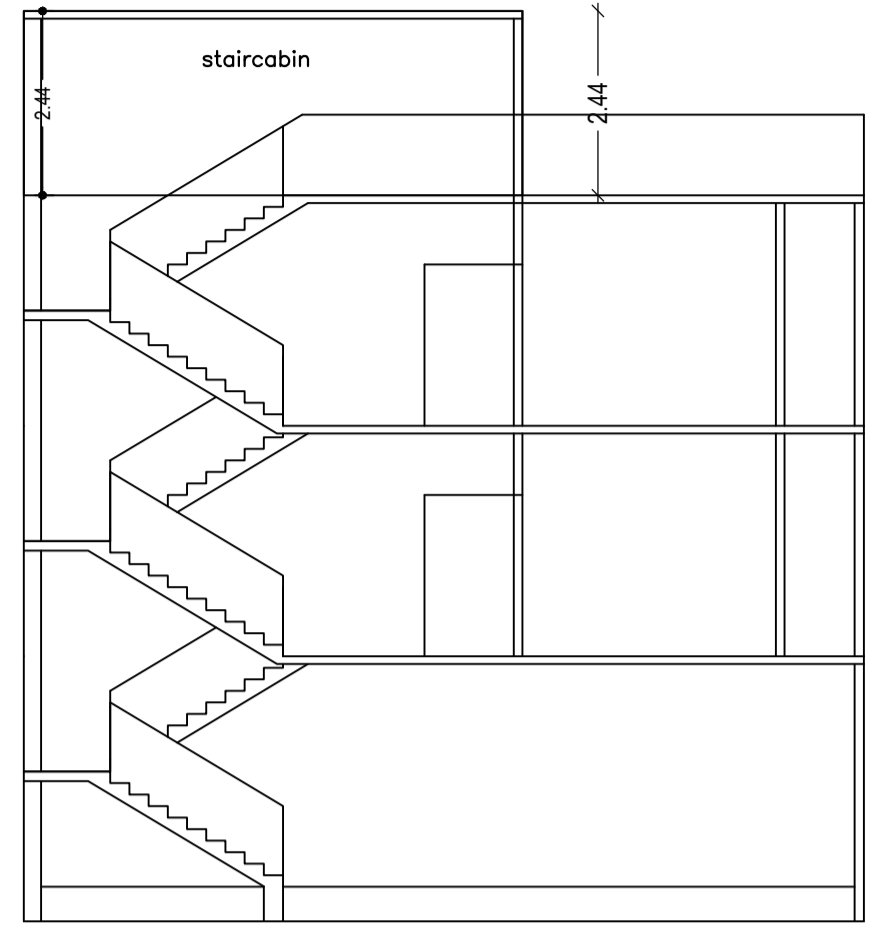

SECTION X-X

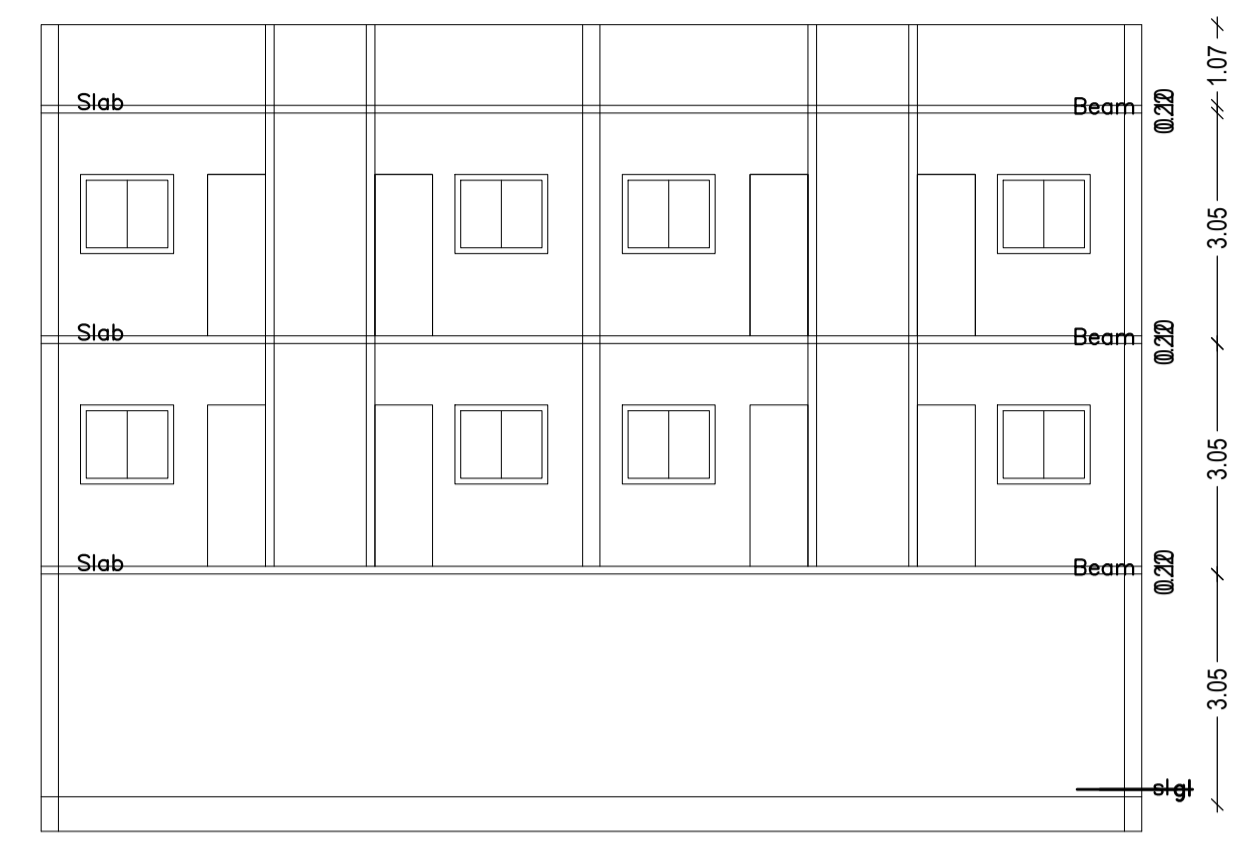

SECTION Y-Y

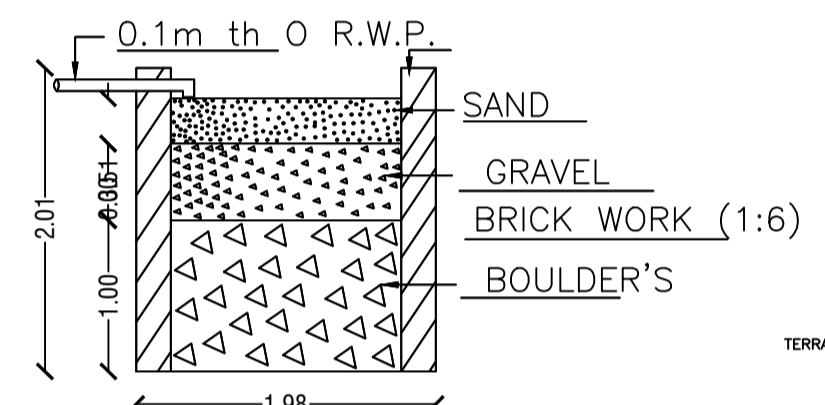

SECTION ON - AA

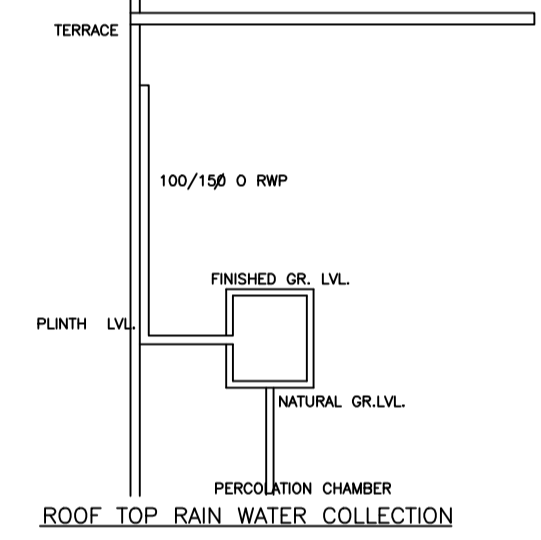

DETAIL'S OF WATER HARVESTING

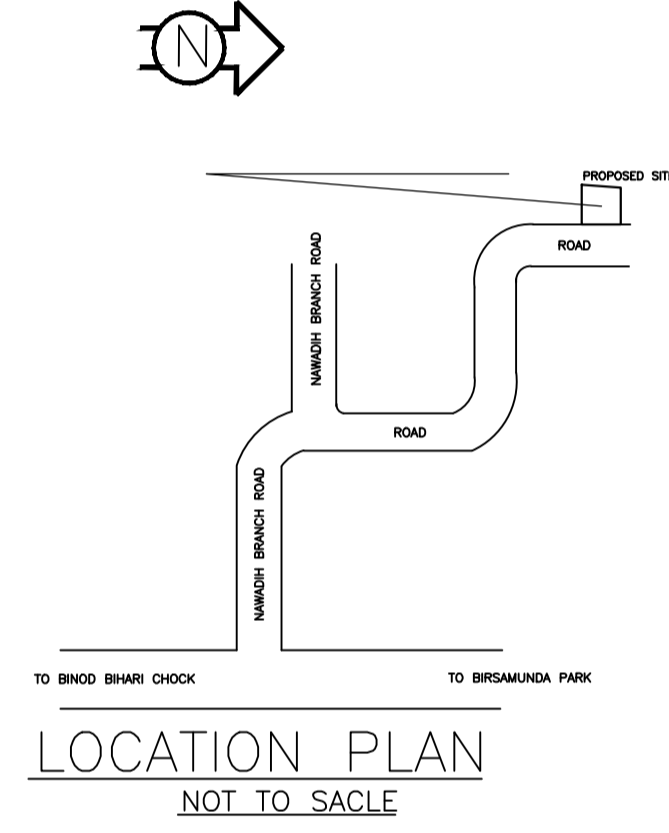

LOCATION PLAN  
NOT TO SCALE

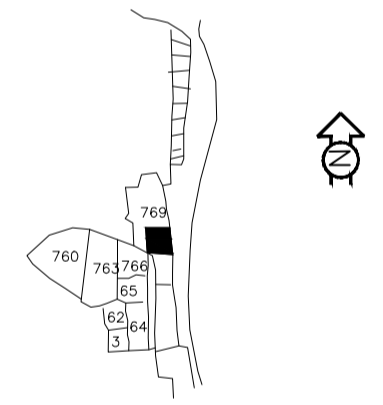

KEY PLAN

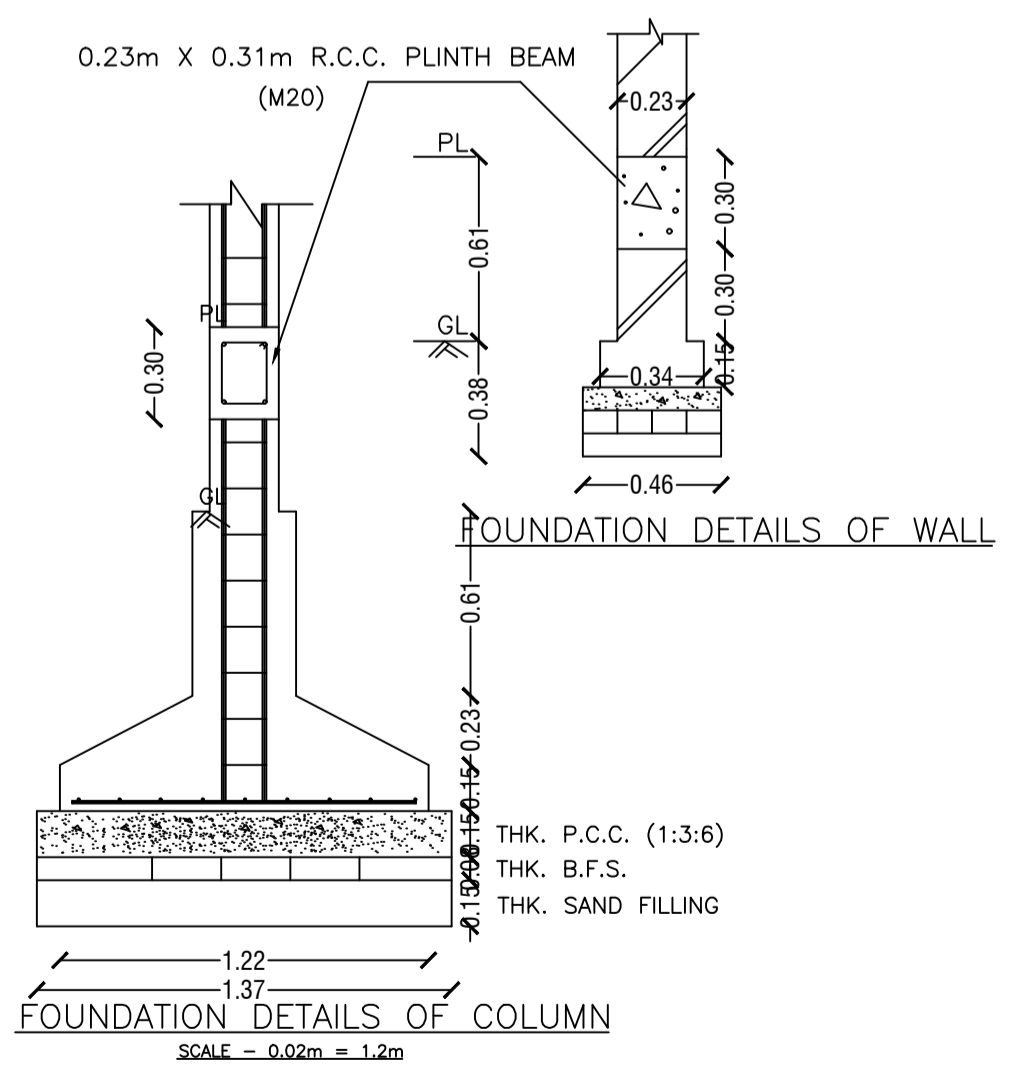

FOUNDATION DETAILS OF COLUMN



FRONT ELEVATION

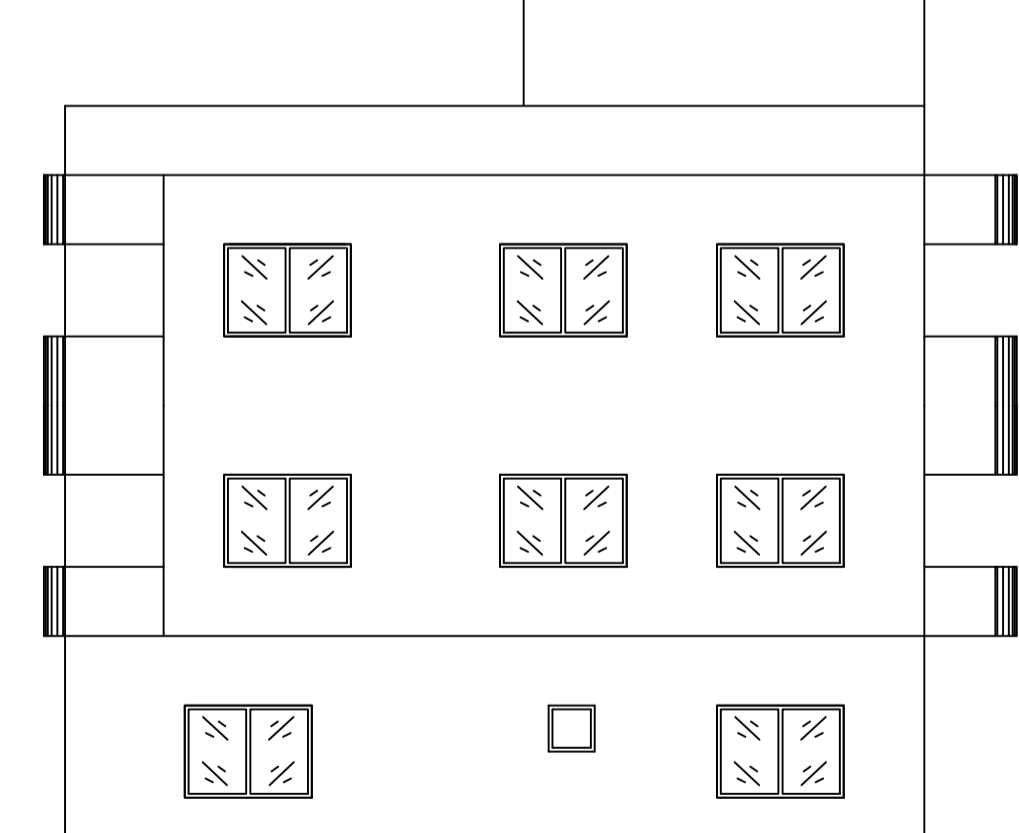

LEFT SIDE ELEVATION

Proposal Basic Information

Proposal File No.	MADA/BP/0026/2019
Owner Name	SRI SHIV SARAN SAW
Khata No	62, NEW-121
Plot No	769,NEW-998
Village Name	Nawadhi
Use	Residential
SubUse	Bungalow/ Dwelling / Non Apartment

AREA STATEMENT MINERAL	VERSION NO.: 1.0/50	SQ.MT.
AREA DEVELOPMENT AUTHORITY	VERSION DATE: 16/10/2020	
PROJECT DETAIL:		
Region: JHARKHAND URBAN LOCAL BODIES	Plot Use: Residential	
District: DHANBAD	Plot SubUse: Bungalow/ Dwelling / Non Apartment	
Authority: MINERAL AREA DEVELOPMENT AUTHORITY	PlotNearby/ReligiousStructure: NA	
Inward_No: MADA/BP/0026/2019	Plot/SubPlot No: 769,NEW-998	
Application Type: General Proposal	North: Plot No. - PART OF THIS PLOT	
Project Type: Building Permission	South: Plot No. - PURCHASER'S OWN LAND	
Nature of Development: New	East: Road Width - 4.54	
Location of Development Area: Old Area	West: Plot No. - PART OF THIS PLOT	
AREA DETAILS:		
AREA OF PLOT (Minimum)	(A)	265.86
NET AREA OF PLOT(Gross Plot Area - Deduction from Gross Plot area)	(A-Deductions)	265.86
Deduction for Balance Plot Area(from Gross Plot Area)		
Common Plot		33.17
Total		33.17
BALANCE AREA OF PLOT(Net Plot Area - Recreational/Amenity space)	(A-Deductions)	232.69
PLOT AREA FOR COVERAGE(Net Plot Area)	(A-Deductions)	265.86
Plot Area for FAR (Net Plot Area + Road/Widening Area)	(A-Deductions)	265.86
COVERAGE CHECK		
Permissible Coverage area ( 60.00 % )		159.52
Proposed Coverage Area ( 59.45 % )		158.04
Total Prop. Coverage Area ( 59.45 % )		158.04
Balance coverage area ( 0.56 % )		1.48
FAR CHECK		
Perm. FAR Area ( 1.50 )		398.79
Total Perm. FAR area		398.79
Residential FAR		360.39
Proposed FAR Area		360.39
Total Proposed FAR Area		360.39
Consumed FAR (Factor)		1.36
Balance FAR Area		38.40
BUILT UP AREA CHECK		
Total Proposed BuiltUp Area		474.11
ARCHITECT (Regd)	RAJEEV RANJAN SINGH	
ENGINEER (Regd)		
SUPERVISOR (Regd)		
OWNER (Regd)	SRI SHIV SARAN SAW	
DEVELOPMENT AUTHORITY		LOCAL BODY

COLOR INDEX	
PLOT BOUNDARY	
ABUTTING ROAD	
PROPOSED CONSTRUCTION	
COMMON PLOT	
ROAD WIDENING AREA	
EXISTING (To be retained)	
EXISTING (To be demolished)	

Buildingwise Floor FAR Details

Floor Name	Building Name A (A)		Total	
	Proposed Built Up Area (Sq.mt.)	Proposed FAR Area (Sq.mt.)	Total Proposed Built Up Area (Sq.mt.)	Total FAR Area (Sq.mt.)
Ground Floor	158.03	44.31	158.03	44.31
First Floor	158.04	158.04	158.04	158.04
Second Floor	158.04	158.04	158.04	158.04
Terrace Floor	0.00	0.00	0.00	0.00
Total :	474.11	360.39	474.11	360.39

Building USE/SUBUSE Details

Building Name	Building Use	Building SubUse	Building Structure
A (A)	Residential	Residential Bldg/Apartment	Non-Highrise

SCHEDULE OF DOOR:

BUILDING NAME	NAME	LENGTH	HEIGHT	NOS
A (A)	d	0.90	2.10	28

SCHEDULE OF WINDOW/VENTILATION:

BUILDING NAME	NAME	LENGTH	HEIGHT	NOS
A (A)	w	1.05	1.20	04
A (A)	w	1.63	1.20	02
A (A)	w	1.80	1.20	24
A (A)	w	2.55	1.20	02
A (A)	w	2.61	1.20	02

UnitBUA Table for Building :A (A)

FLOOR	Name	UnitBUA Type	UnitBUA Area	Carpet Area	No. of Rooms	No. of Tenement
GROUND FLOOR PLAN	SPLIT 1	FLAT	360.39	360.21	4	1
TYPICAL - 1, 2 FLOOR PLAN	SPLIT 1	FLAT	0.00	0.00	14	0
Total:			360.39	360.21	32	1

FAR & Tenement Details (Table 4c-1)

Building	No. of Same Bldg	Total Built Up Area (Sq.mt.)	Deductions (Area in Sq.mt.)		Proposed FAR Area (Sq.mt.)	Total FAR Area (Sq.mt.)	Total Consumed Additional FAR Area (Sq.mt.)	Trnmt (No.)
			Parking	Resi.				
A (A)	1	474.11	113.72	360.39	360.39	360.39	01	
Grand Total :	1	474.11	113.72	360.39	360.39	360.39	01	

Building :A (A)

Floor Name	Total Built Up Area (Sq.mt.)	Deductions (Area in Sq.mt.)		Proposed FAR Area (Sq.mt.)	Total FAR Area (Sq.mt.)	Total Consumed Additional FAR Area (Sq.mt.)	Trnmt (No.)
		Parking	Resi.				
Ground Floor	158.03	113.72	44.31	44.31	44.31	01	
First Floor	158.04	0.00	158.04	158.04	158.04	00	
Second Floor	158.04	0.00	158.04	158.04	158.04	00	
Terrace Floor	0.00	0.00	0.00	0.00	0.00	00	
Total :	474.11	113.72	360.39	360.39	360.39	01	
Total Number of Same Buildings :	1						
Total :	474.11	113.72	360.39	360.39	360.39	01	

LTP NAME AND SIGNATURE RAJEEV RANJAN SINGH MADA/ENG/0004/2019	STRUCTURAL ENG'S NAME AND SIGNATURE	BUILDER NAME AND SIGNATURE	DIGITAL SIGNATURE
---	-------------------------------------	----------------------------	-------------------

Proposal Basic Information

Proposal File No.	MADA/BP/0026/2019
Owner Name	SRI SHIV SARAN SAW
Khata No	62, NEW-121
Plot No	769,NEW-998
Village Name	Nawadhi
Use	Residential
SubUse	Bungalow/ Dwelling / Non Apartment

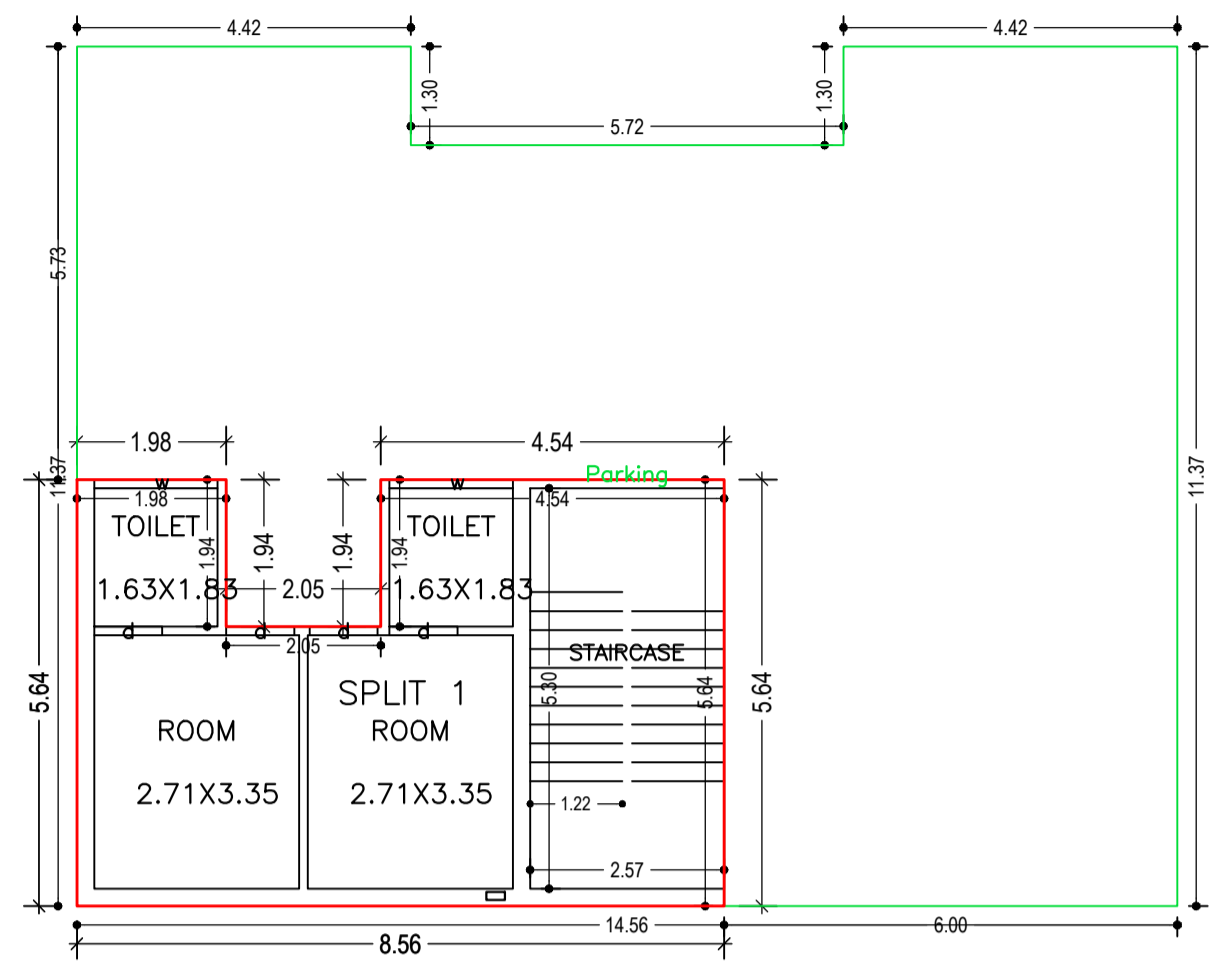

GROUND FLOOR PLAN  
(Proposed)  
(SCALE 1:100)

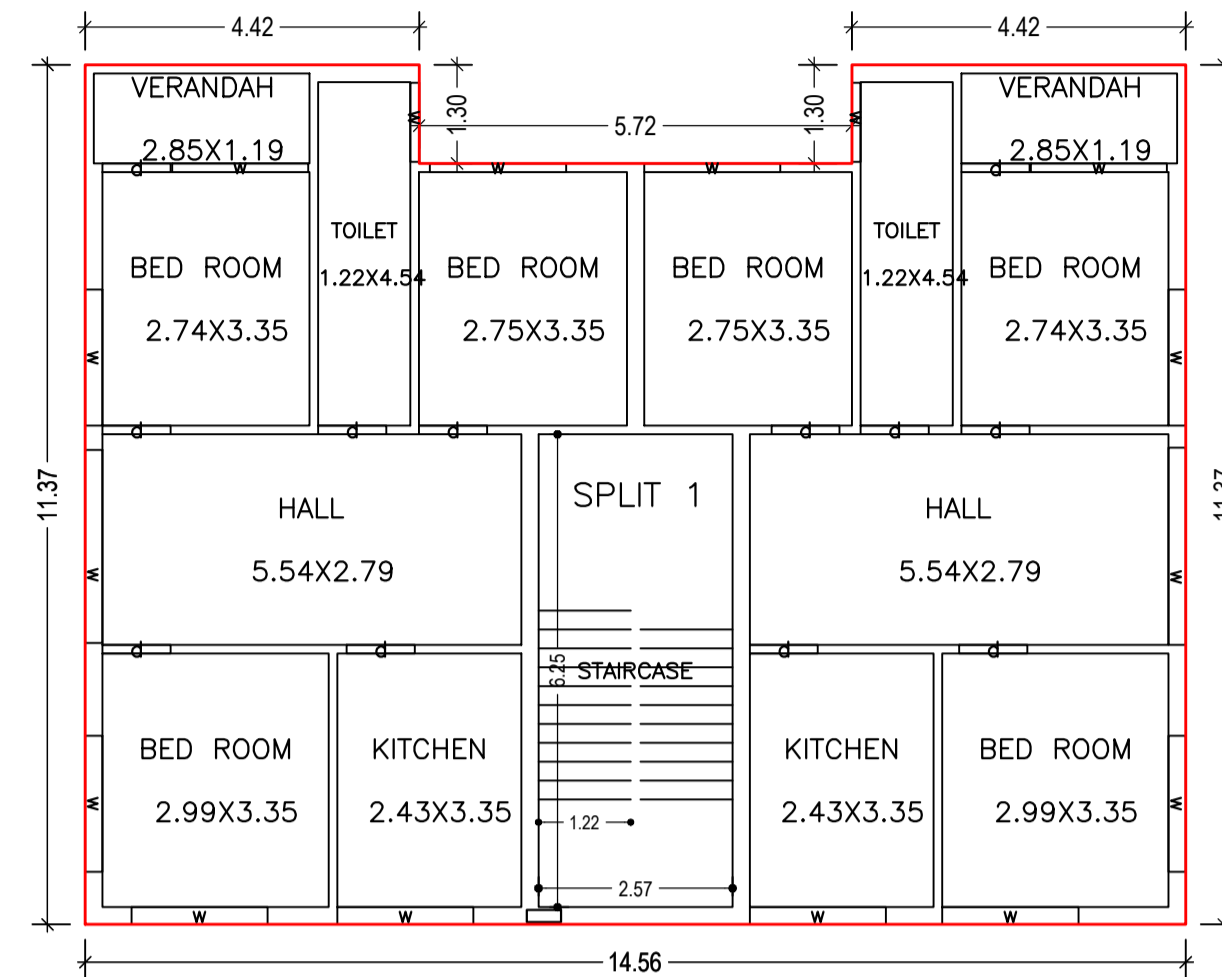

TYPICAL - 1, 2 FLOOR PLAN  
(Proposed)  
(SCALE 1:100)

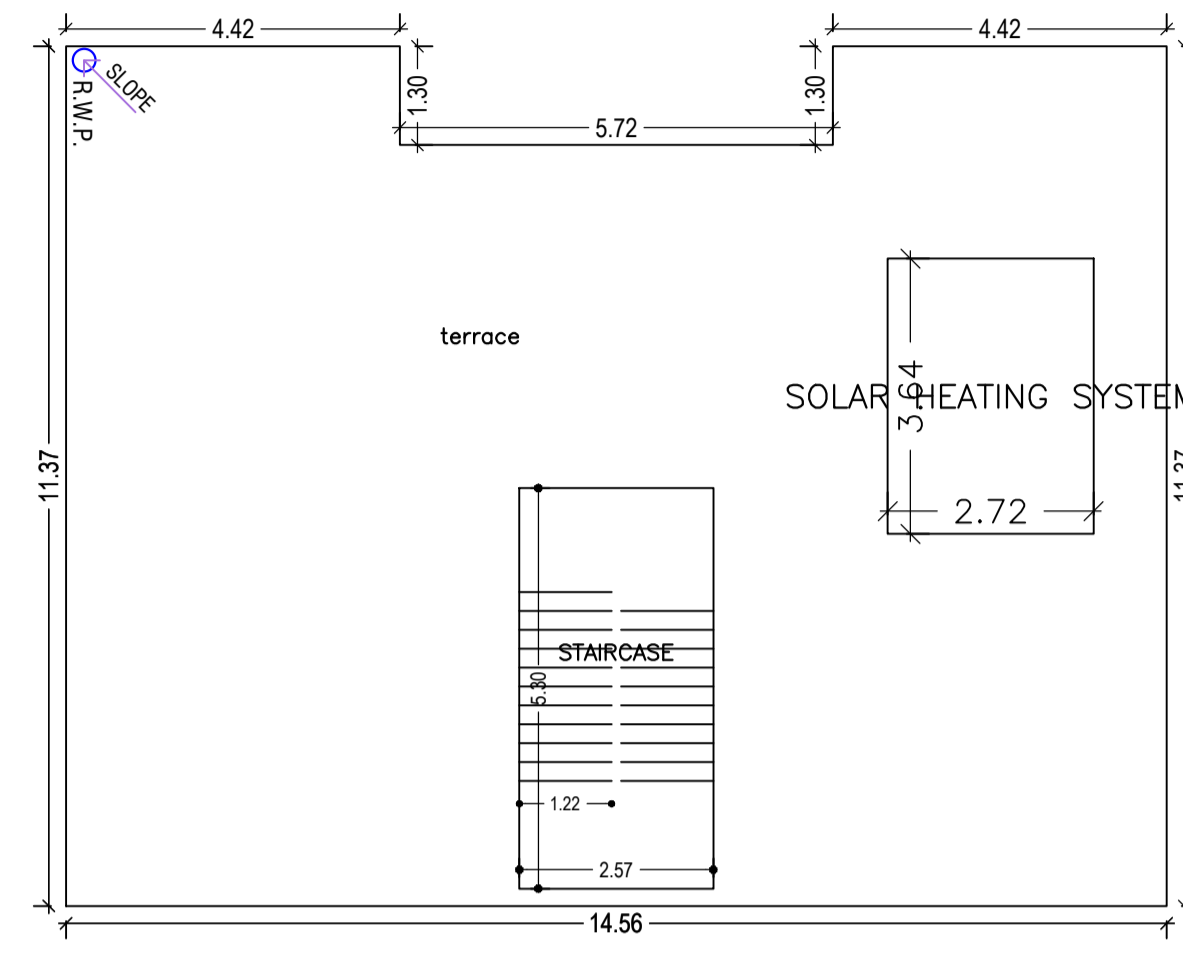

TERRACE FLOOR PLAN  
(SCALE 1:100)

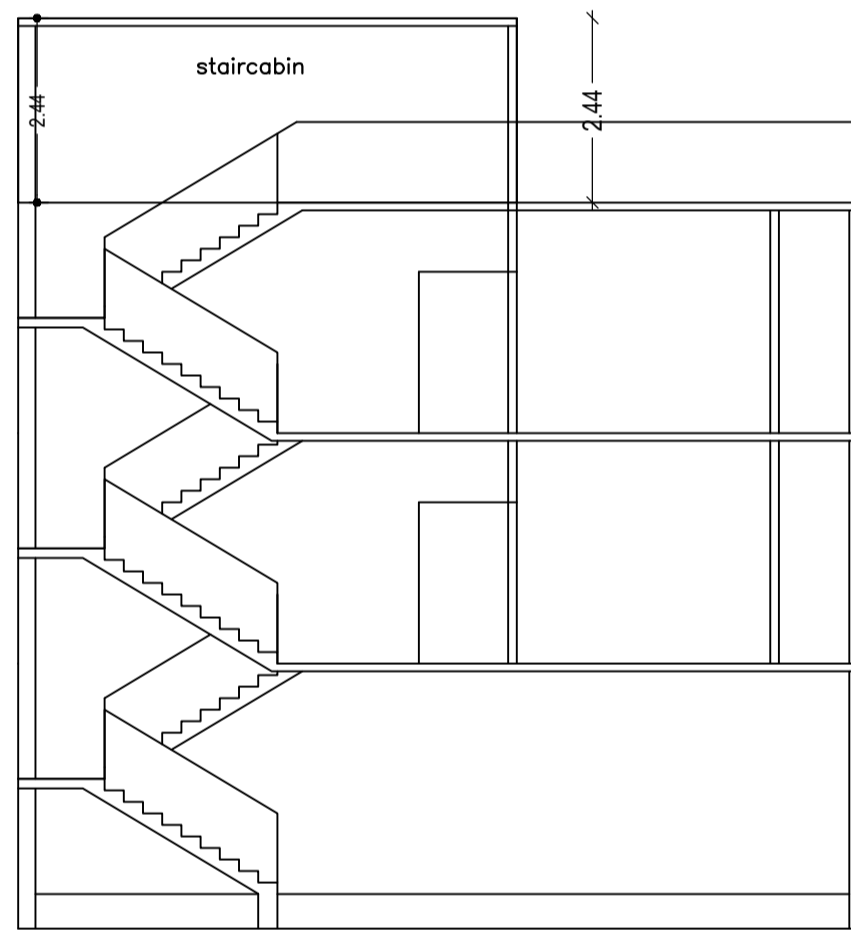

SECTION X-X

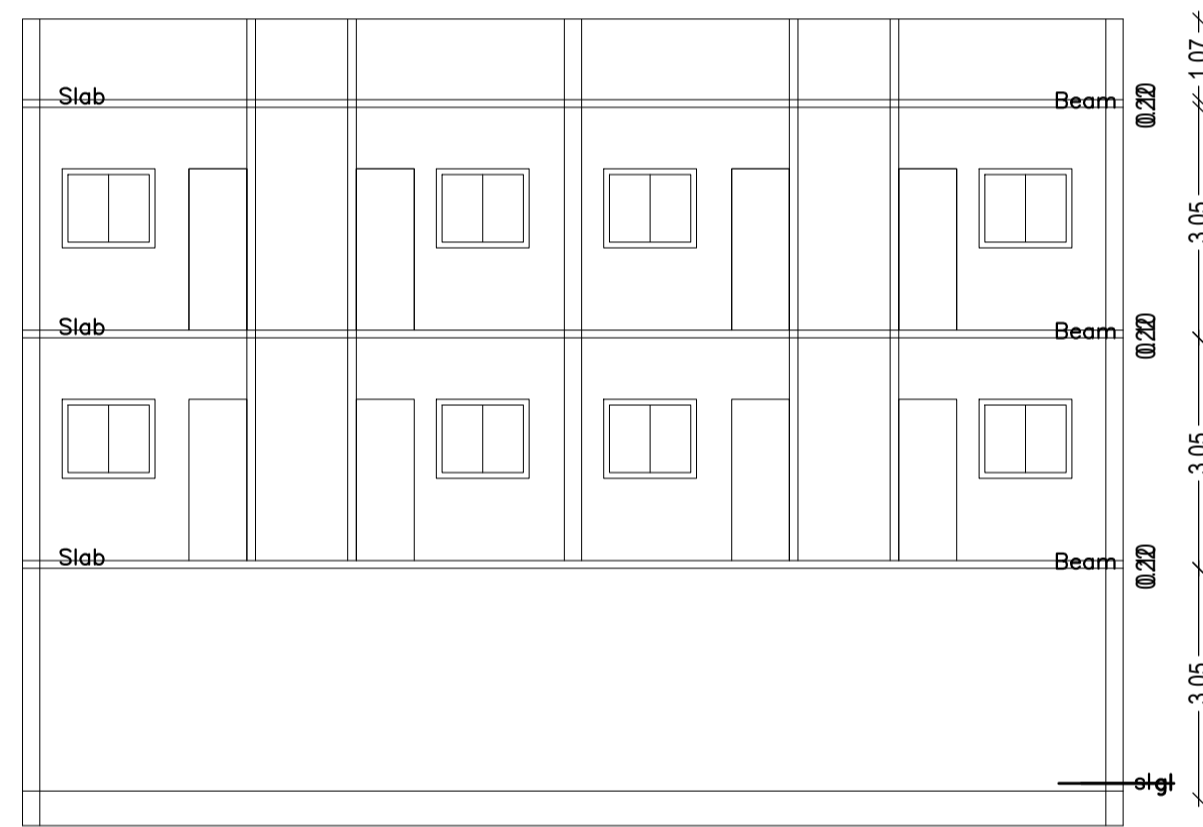

SECTION Y-Y

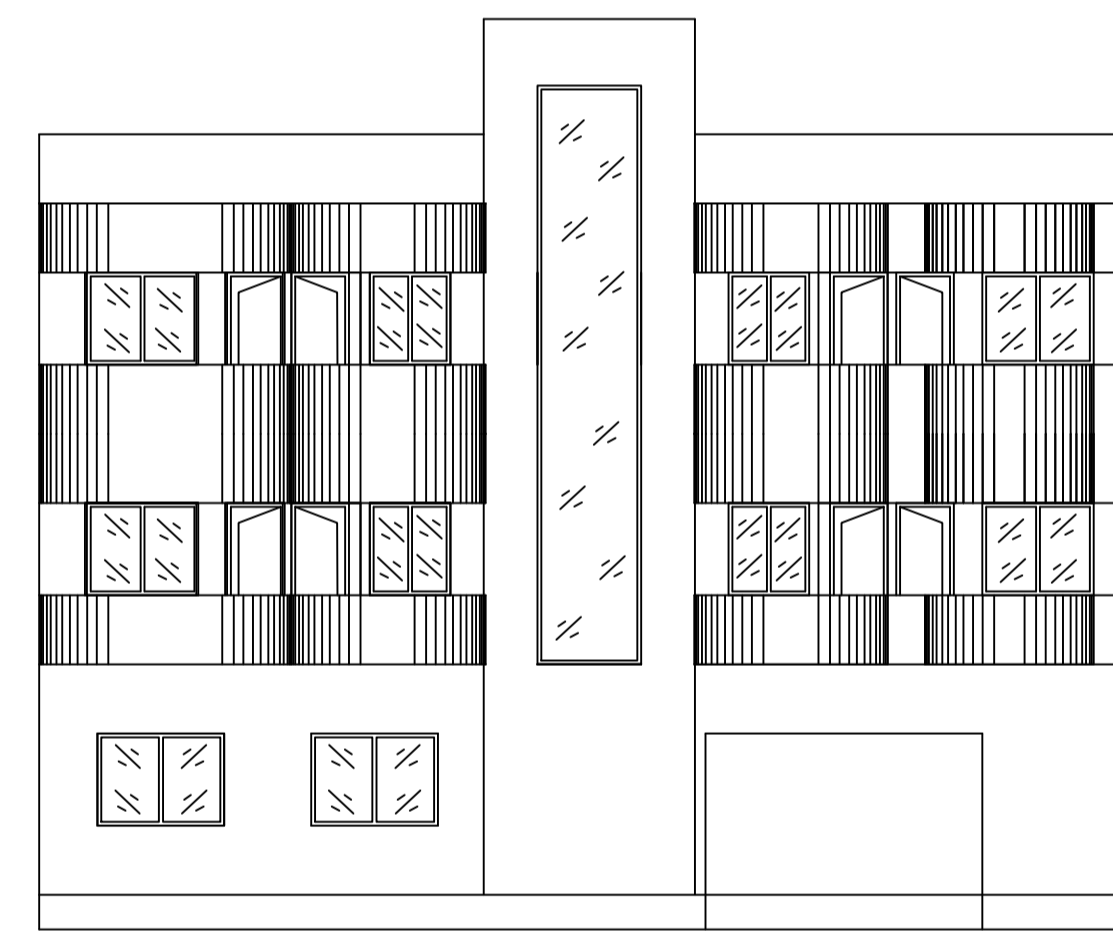

FRONT ELEVATION

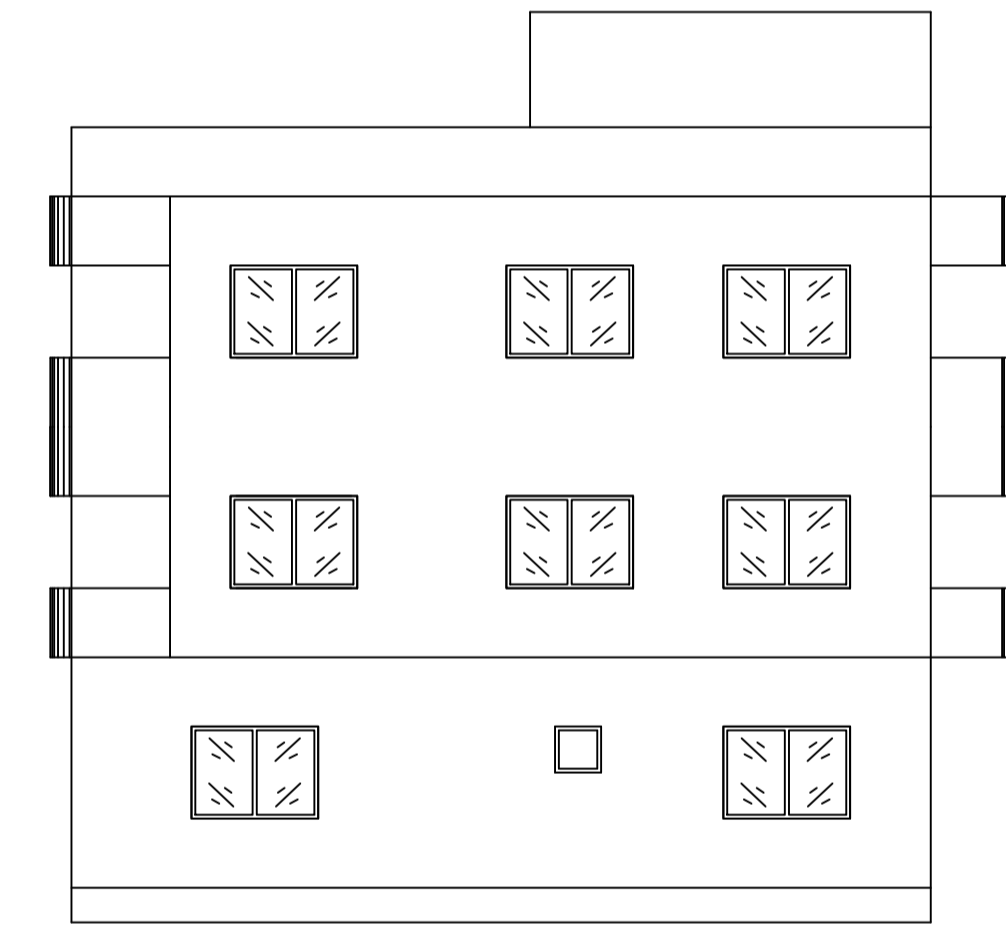

LEFT SIDE ELEVATION

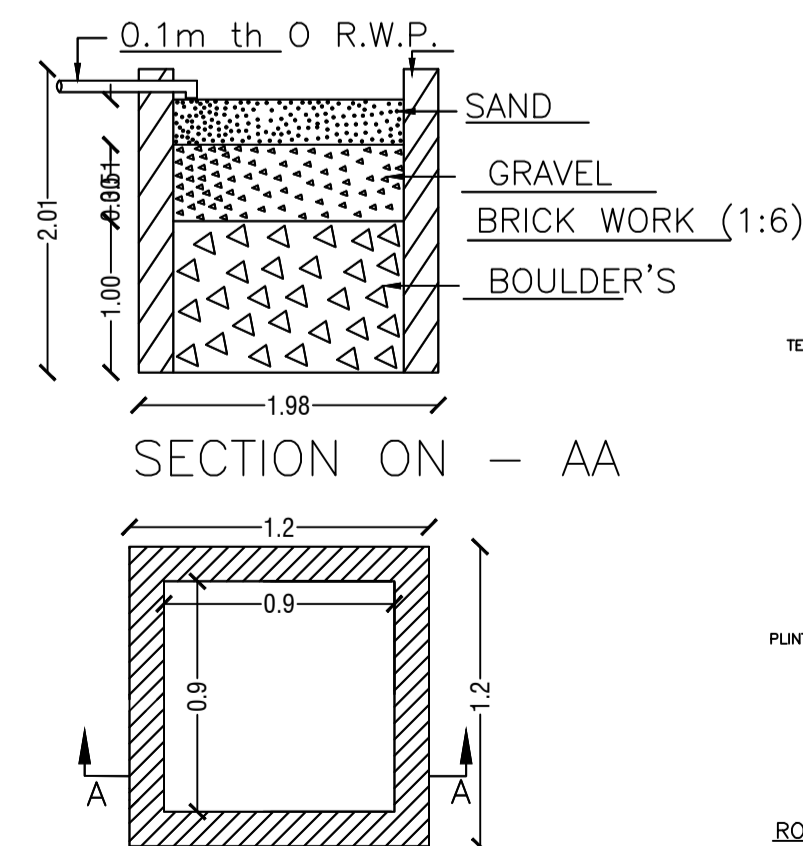

DETAIL'S OF WATER HARVESTING

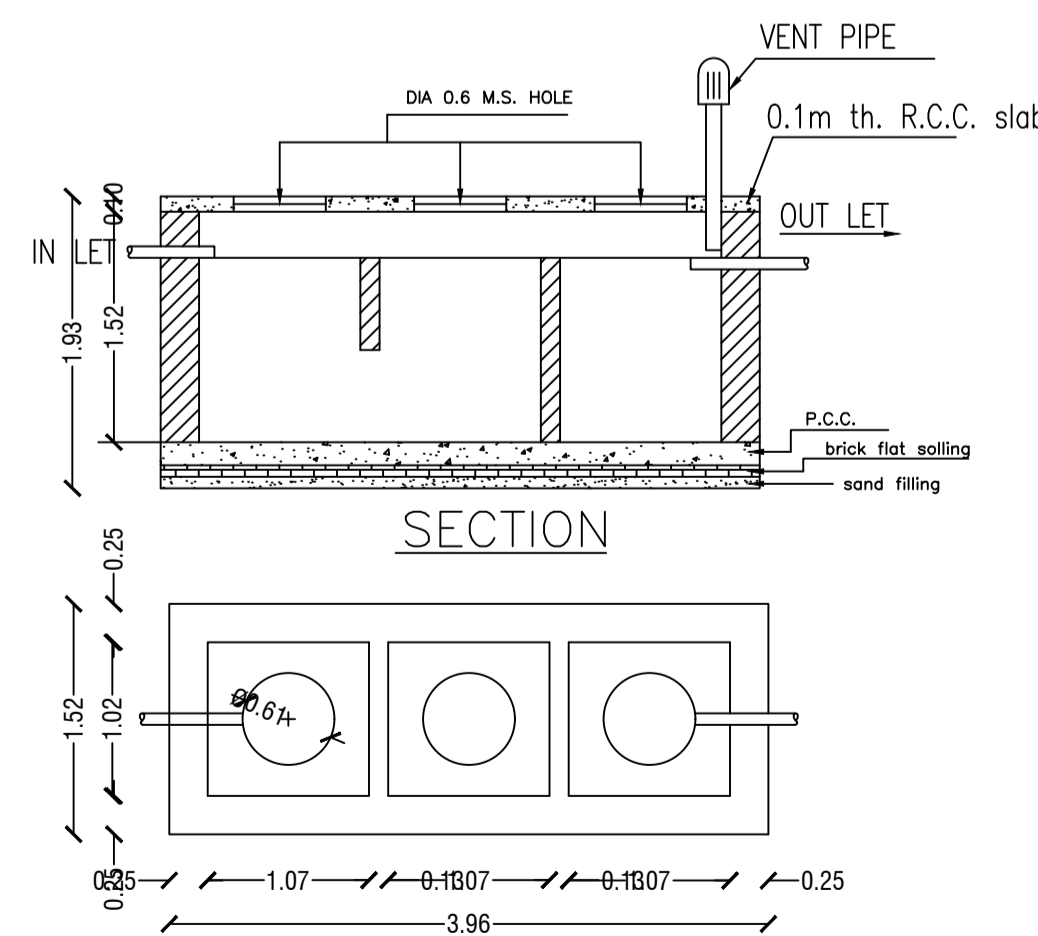
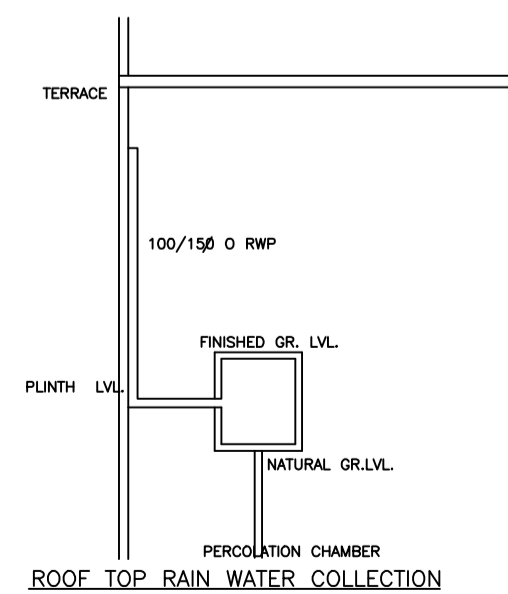

DETAILS OF SEPTIC TANK

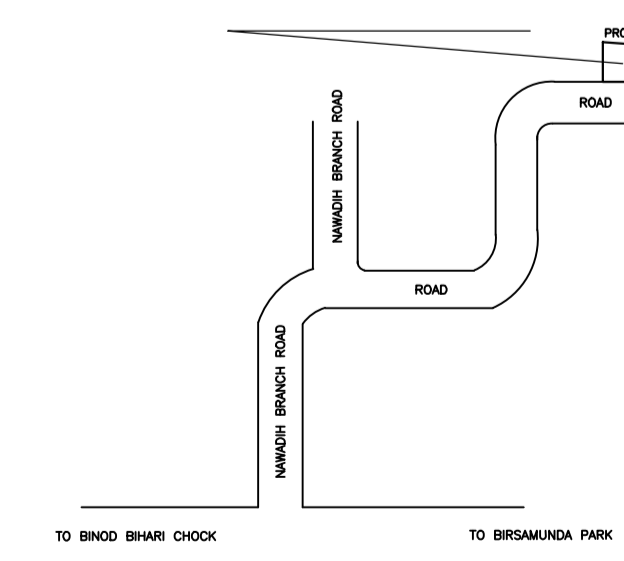
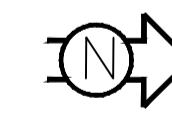

LOCATION PLAN  
NOT TO SCALE

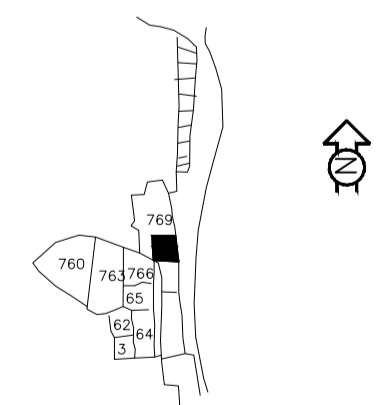

KEY PLAN

LTP NAME AND SIGNATURE	STRUCTURAL ENG'S NAME AND SIGNATURE	BUILDER NAME AND SIGNATURE	DIGITAL SIGNATURE
RAJEEV RANJAN SINGH MADA/ENG/0004/2019			