

**SCHEDULE OF DOOR:**

BUILDING NAME	NAME	LENGTH	HEIGHT	NOS
A (A)	D	0.76	2.10	03
A (A)	D	0.92	2.10	01
A (A)	D	1.07	2.10	01
A (A)	D	1.09	2.10	01
A (A)	D	1.17	2.10	01
A (A)	D	1.22	2.10	01

**SCHEDULE OF WINDOW/VENTILATION:**

BUILDING NAME	NAME	LENGTH	HEIGHT	NOS
A (A)	W	0.48	1.20	01
A (A)	W	0.61	1.20	01
A (A)	W	0.91	1.20	02
A (A)	W	1.52	1.20	06

**Building :A (A)**

Floor Name	Total Built Up Area (Sq.mt.)	Proposed FAR Area (Sq.mt.) Resi.	Total FAR Area (Sq.mt.)	Total Consumed Additional FAR Area (Sq.mt.)	Tnmt (No.)
Ground Floor	90.68	90.68	90.68	90.68	01
Terrace Floor	0.00	0.00	0.00	0.00	00
<b>Total :</b>	<b>90.68</b>	<b>90.68</b>	<b>90.68</b>	<b>90.68</b>	<b>01</b>
Total Number of Same Buildings :	1				
<b>Total :</b>	<b>90.68</b>	<b>90.68</b>	<b>90.68</b>	<b>90.68</b>	<b>01</b>

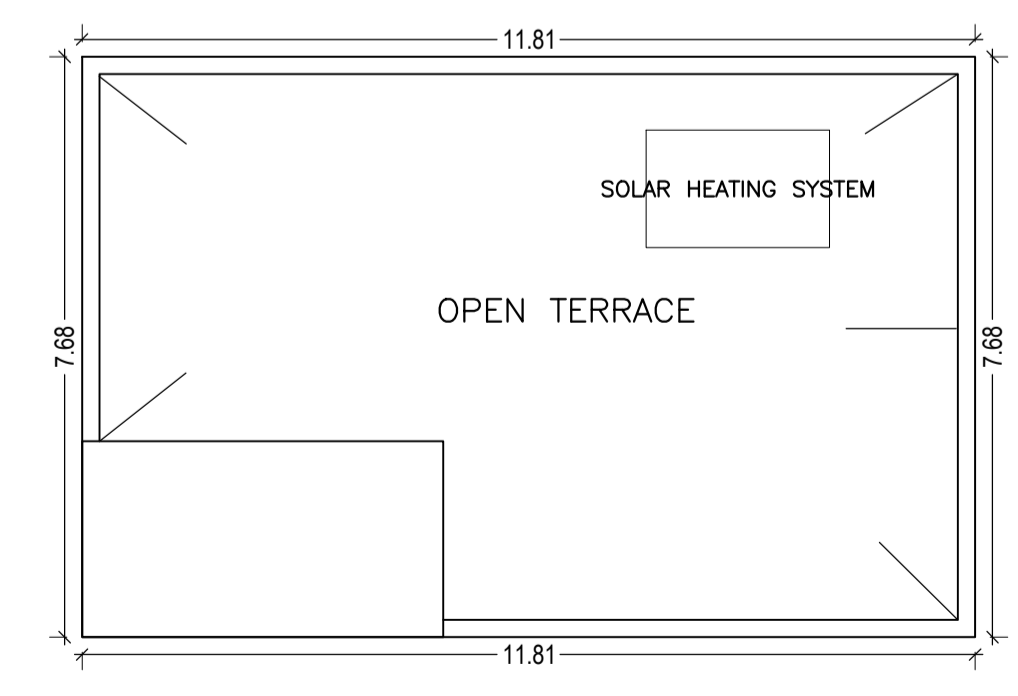
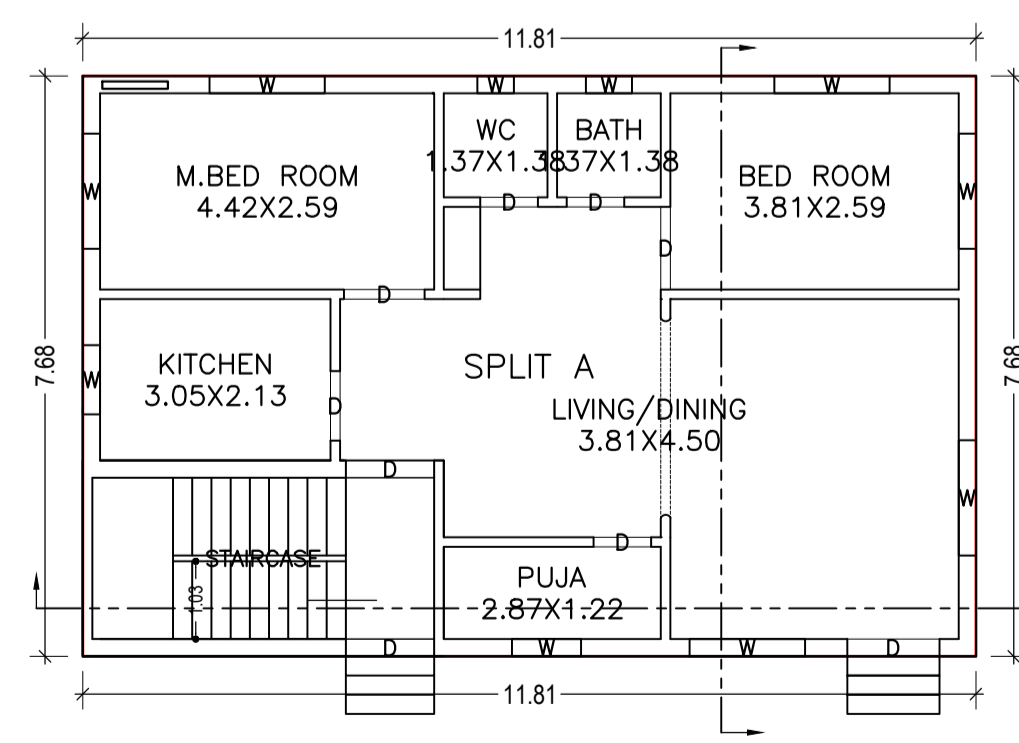
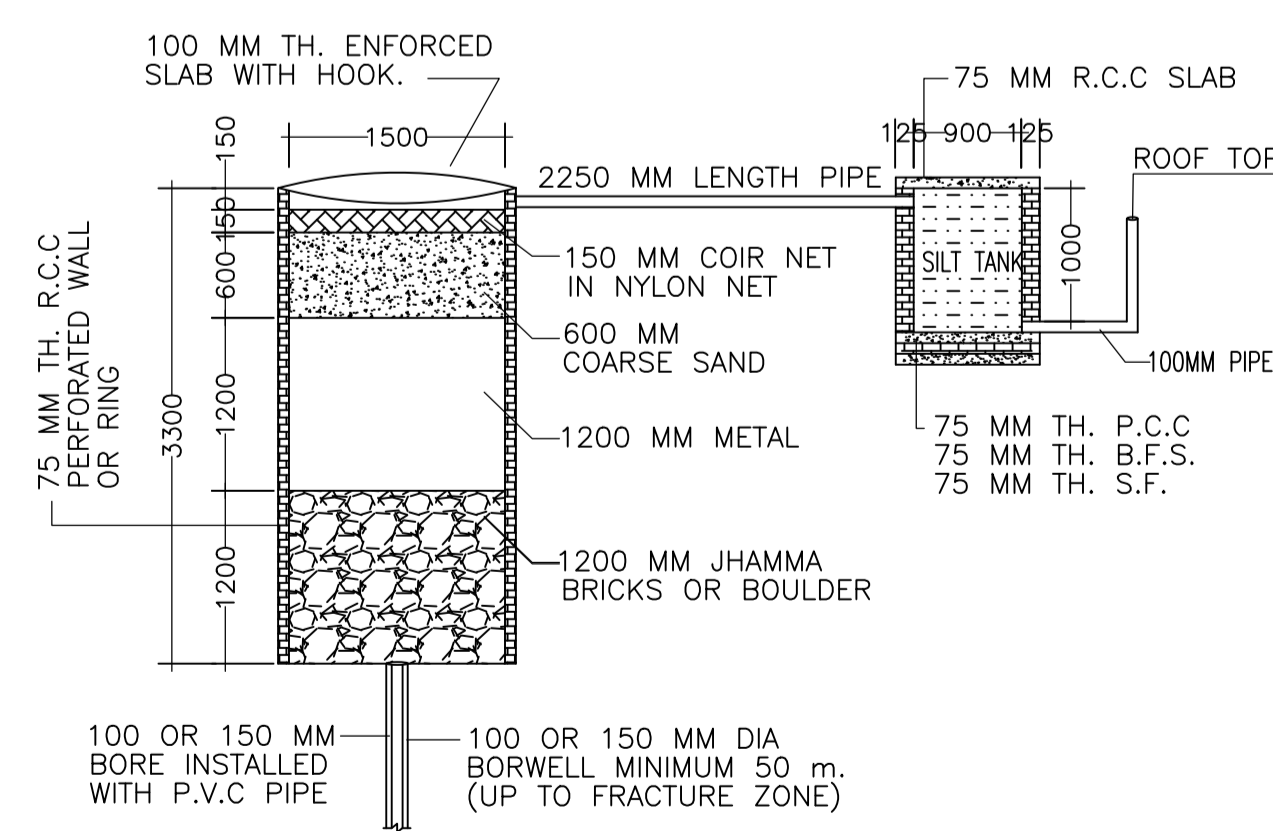

**Proposal Basic Information**

Proposal File No.	MADA/BP/0030/2019
Owner Name	SRI KAILASH KUMAR
Khata No	OLD - 208 , NEW - 416
Plot No	OLD - 3496 , NEW - 4516
Village Name	Ballapur
Use	Residential
SubUse	Bungalow/ Dwelling / Non Apartment

**AREA STATEMENT MINERAL AREA DEVELOPMENT AUTHORITY**

VERSION NO.: 1.0.46  
VERSION DATE: 22/06/2020

**PROJECT DETAIL:**

Region: JHARKHAND URBAN LOCAL BODIES	Plot Use: Residential
District: DHANBAD	Plot SubUse: Bungalow/ Dwelling / Non Apartment
Authority: MINERAL AREA DEVELOPMENT AUTHORITY	PlotNearby/Religious/Structure: NA
Inward No: MADA/BP/0030/2019	Plot/SubPlot No: OLD - 3496 , NEW - 4516
Application Type: General Proposal	North: Road Width - 4.57 M WIDE ROAD
Project Type: Building Permission	South: Plot No. - VIVHA SINGH
Nature of Development: New	East: Road Width - 4.57 M WIDE ROAD
Location of Development Area: Old Area	West: Plot No. - USHA SHARMA

**AREA DETAILS:**

AREA OF PLOT (Minimum)	(A)	SQ.MT.
NET AREA OF PLOT(Gross Plot Area - Deduction from Gross Plot area)	(A-Deductions)	215.85
Deduction for Balance Plot Area(from Gross Plot Area)		
Common Plot		20.40
Total		20.40
BALANCE AREA OF PLOT(Net Plot Area - Recreational/Amenity space)	(A-Deductions)	195.45
PLOT AREA FOR COVERAGE(Net Plot Area)	(A-Deductions)	215.85
Plot Area for FAR (Net Plot Area + Road Widening Area)	(A-Deductions)	215.85

**COVERAGE CHECK**

Permissible Coverage area ( 70.00 % )	151.10
Proposed Coverage Area ( 42.01 % )	90.68
Total Prop. Coverage Area ( 42.01 % )	90.68
Balance coverage area ( 27.99 % )	60.42

**FAR CHECK**

Perm. FAR Area ( 1.50 )	323.78
Total Perm. FAR area	323.78
Residential FAR	90.68
Proposed FAR Area	90.68
Total Proposed FAR Area	90.68
Consumed FAR (Factor)	0.42
Balance FAR Area	233.10

**BUILT UP AREA CHECK**

Total Proposed BuiltUp Area	90.68
-----------------------------	-------

**ARCHITECT (Regd)** AMARENDRA KUMAR  
**ENGINEER (Regd)**  
**SUPERVISOR (Regd)**  
**OWNER (Regd)** SRI KAILASH KUMAR  
**DEVELOPMENT AUTHORITY** LOCAL BODY

**COLOR INDEX**

PLOT BOUNDARY	Black
ABUTTING ROAD	Green
PROPOSED CONSTRUCTION	Red
COMMON PLOT	Yellow
ROAD WIDENING AREA	Blue
EXISTING (To be retained)	Orange
EXISTING (To be demolished)	Grey

**Buildingwise Floor FAR Details**

Floor Name	Building Name A (A)		Total	
	Proposed Built Up Area (Sq.mt.)	Proposed FAR Area (Sq.mt.)	Total Proposed Built Up Area (Sq.mt.)	Total FAR Area (Sq.mt.)
Ground Floor	90.68	90.68	90.68	90.68
Terrace Floor	0.00	0.00	0.00	0.00
<b>Total :</b>	<b>90.68</b>	<b>90.68</b>	<b>90.68</b>	<b>90.68</b>

**Building USE/SUBUSE Details**

Building Name	Building Use	Building SubUse	Building Structure
A (A)	Residential	Bungalow/ Dwelling / Non Apartment	Non-Highrise

**FAR & Tenement Details (Table 4c-1)**

Building	No. of Same Bldg	Total Built Up Area (Sq.mt.)	Proposed FAR Area (Sq.mt.) Resi.	Total FAR Area (Sq.mt.)	Total Consumed Additional FAR Area (Sq.mt.)	Tnmt (No.)
A (A)	1	90.68	90.68	90.68	90.68	01
<b>Grand Total :</b>	<b>1</b>	<b>90.68</b>	<b>90.68</b>	<b>90.68</b>	<b>90.68</b>	<b>01</b>

**UnitBUA Table for Building :A (A)**

FLOOR	Name	UnitBUA Type	UnitBUA Area	Carpet Area	No. of Rooms	No. of Tenement
GROUND FLOOR PLAN	SPLIT A	FLAT	90.68	90.60	7	1
<b>Total:</b>	-	-	<b>90.68</b>	<b>90.60</b>	<b>7</b>	<b>1</b>

LTP NAME AND SIGNATURE	STRUCTURAL ENG'S NAME AND SIGNATURE	BUILDER NAME AND SIGNATURE	DIGITAL SIGNATURE
AMARENDRA KUMAR MADA/ENG/0008/2019			