

SITE PLAN

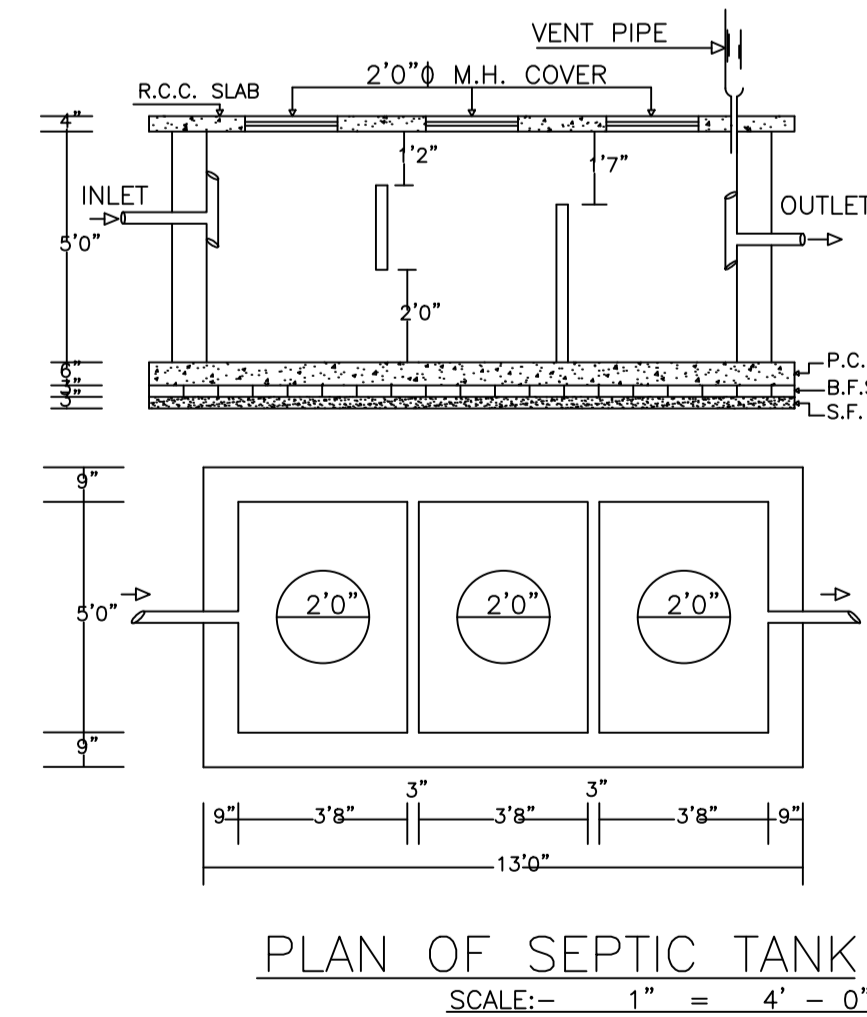
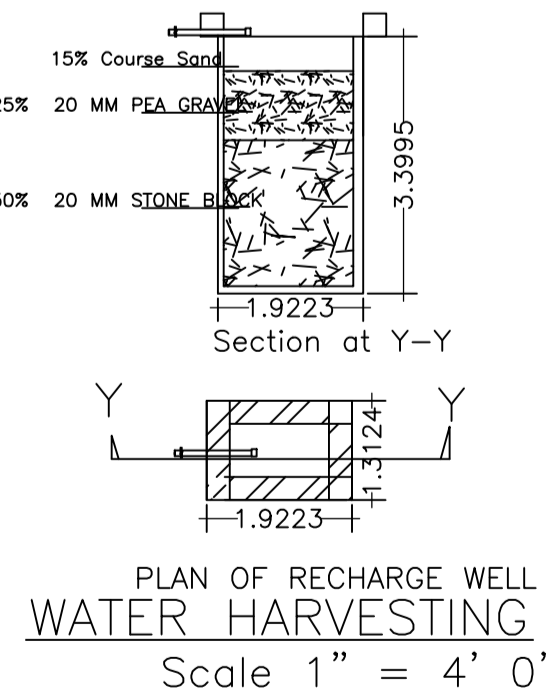
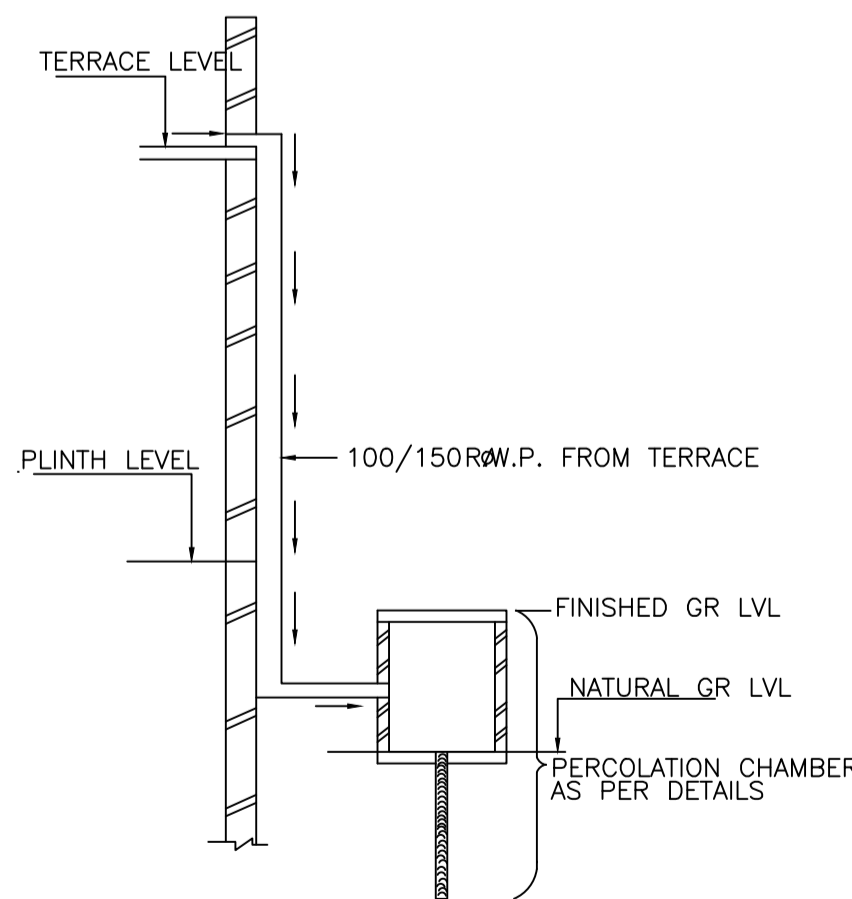
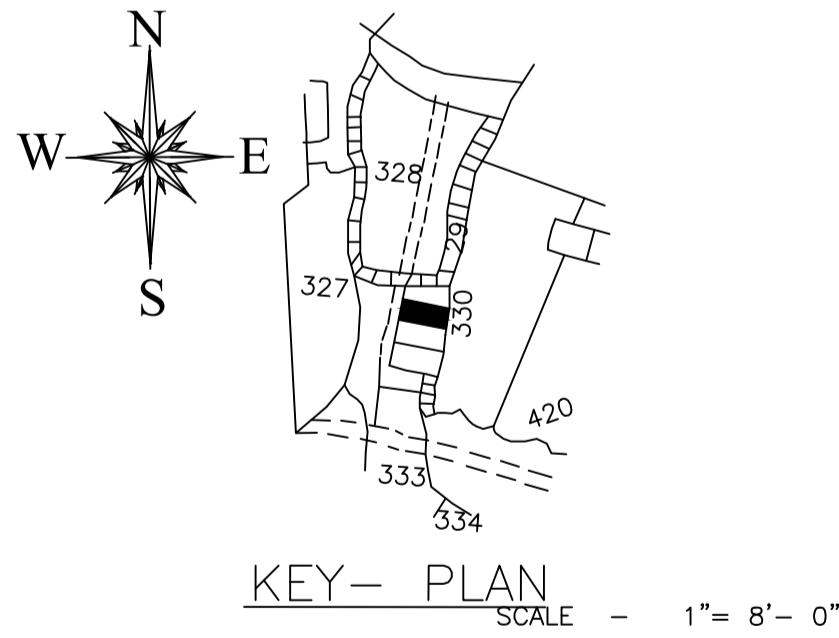

Proposal Basic Information

Proposal File No.	MADA/BP/0031/2019
Owner Name	SRI ARUN KUMAR SHARMA
Khata No	24, NEW-100
Plot No	330,331,332, NEW-100
Village Name	Narayanpur
Use	Residential
SubUse	Bungalow/ Dwelling / Non Apartment

AREA STATEMENT MINERAL AREA DEVELOPMENT AUTHORITY	VERSION NO.: 1.0.48 VERSION DATE: 22/06/2020
PROJECT DETAIL:	
Region: JHARKHAND URBAN LOCAL BODIES	Plot Use: Residential
District: DHANBAD	Plot SubUse: Bungalow/ Dwelling / Non Apartment
Authority: MINERAL AREA DEVELOPMENT AUTHORITY	PlotNearbyReligiousStructure: NA
Inward No: MADA/BP/0031/2019	Plot/SubPlot No: 330,331,332, NEW-100
Application Type: General Proposal	North: Plot No. - VENDORS OWN
Project Type: Building Permission	South: Plot No. - VENDORS OWN
Nature of Development: New	East: Plot No. - VENDORS OWN
Location of Development Area: Old Area	West: Road Width - 6.09
AREA DETAILS:	
AREA OF PLOT (Minimum)	(A) 265.17 SQ.MT.
NET AREA OF PLOT(Gross Plot Area - Deduction from Gross Plot area)	(A-Deductions) 265.17
Deduction for Balance Plot Area(from Gross Plot Area)	
Common Plot	62.61
Total	62.61
BALANCE AREA OF PLOT(Net Plot Area - Recreational/Amenity space)	(A-Deductions) 202.56
PLOT AREA FOR COVERAGE(Net Plot Area)	(A-Deductions) 265.17
Plot Area for FAR (Net Plot Area + RoadWidening Area)	(A-Deductions) 265.17
COVERAGE CHECK	
Permissible Coverage area (60.00 %)	159.10
Proposed Coverage Area (34.67 %)	91.94
Total Prop. Coverage Area (34.67 %)	91.94
Balance coverage area (25.33 %)	67.16
FAR CHECK	
Perm. FAR Area (1.80)	477.31
Total Perm. FAR area	477.31
Residential FAR	183.88
Proposed FAR Area	183.88
Total Proposed FAR Area	183.88
Consumed FAR (Factor)	0.69
Balance FAR Area	293.43
BUILT UP AREA CHECK	
Total Proposed BuiltUp Area	183.88
ARCHITECT (Regd)	RAJEEV RANJAN SINGH
ENGINEER (Regd)	
SUPERVISOR (Regd)	
OWNER (Regd)	SRI ARUN KUMAR SHARMA
DEVELOPMENT AUTHORITY	LOCAL BODY

COLOR INDEX	
PLOT BOUNDARY	Black
ABUTTING ROAD	Green
PROPOSED CONSTRUCTION	Red
COMMON PLOT	Yellow
ROAD WIDENING AREA	Light Blue
EXISTING (To be retained)	Blue
EXISTING (To be demolished)	Light Yellow

Floor Name	Building Name		Total	
	Proposed Built Up Area (Sq.mt.)	Proposed FAR Area (Sq.mt.)	Total Proposed Built Up Area (Sq.mt.)	Total FAR Area (Sq.mt.)
Ground Floor	91.94	91.94	91.94	91.94
First Floor	91.94	91.94	91.94	91.94
Terrace Floor	0.00	0.00	0.00	0.00
Total :	183.88	183.88	183.88	183.88

Building Name	Building Use	Building SubUse	Building Structure
A (SRI ARUN KUMAR SHARMA)	Residential	Residential Bldg/Apartment	Non-Highrise

Building :A (SRI ARUN KUMAR SHARMA)					
Floor Name	Total Built Up Area (Sq.mt.)	Proposed FAR Area (Sq.mt.) Resi.	Total FAR Area (Sq.mt.)	Total Consumed Additional FAR Area (Sq.mt.)	Tnmt (No.)
Ground Floor	91.94	91.94	91.94	91.94	01
First Floor	91.94	91.94	91.94	91.94	00
Terrace Floor	0.00	0.00	0.00	0.00	00
Total :	183.88	183.88	183.88	183.88	01
Total Number of Same Buildings :	1				
Total :	183.88	183.88	183.88	183.88	01

SCHEDULE OF DOOR:

BUILDING NAME	NAME	LENGTH	HEIGHT	NOS
A (SRI ARUN KUMAR SHARMA)	D	0.61	2.10	02
A (SRI ARUN KUMAR SHARMA)	D	0.76	2.10	06
A (SRI ARUN KUMAR SHARMA)	D	0.91	2.10	02
A (SRI ARUN KUMAR SHARMA)	D	0.99	2.10	08
A (SRI ARUN KUMAR SHARMA)	D	1.22	2.10	02

SCHEDULE OF WINDOW/VENTILATION:

BUILDING NAME	NAME	LENGTH	HEIGHT	NOS
A (SRI ARUN KUMAR SHARMA)	W	0.61	1.20	06
A (SRI ARUN KUMAR SHARMA)	W	0.76	1.20	02
A (SRI ARUN KUMAR SHARMA)	W	1.22	1.20	06
A (SRI ARUN KUMAR SHARMA)	W	1.52	1.20	08
A (SRI ARUN KUMAR SHARMA)	W	1.59	1.20	02
A (SRI ARUN KUMAR SHARMA)	W	2.47	1.20	01
A (SRI ARUN KUMAR SHARMA)	W	2.50	1.20	01

UnitBUA Table for Building :A (SRI ARUN KUMAR SHARMA)

FLOOR	Name	UnitBUA Type	UnitBUA Area	Carpet Area	No. of Rooms	No. of Tenement
GROUND FLOOR PLAN	SPLIT A	FLAT	183.88	183.24	9	1
FIRST FLOOR PLAN	SPLIT A	FLAT	0.00	0.00	9	0
Total:	-	-	183.88	183.24	18	1

FAR & Tenement Details (Table 4c-1)

Building	No. of Same Bldg	Total Built Up Area (Sq.mt.)	Proposed FAR Area (Sq.mt.) Resi.	Total FAR Area (Sq.mt.)	Total Consumed Additional FAR Area (Sq.mt.)	Tnmt (No.)
A (SRI ARUN KUMAR SHARMA)	1	183.88	183.88	183.88	183.88	01
Grand Total :	1	183.88	183.88	183.88	183.88	01

LTP NAME AND SIGNATURE	STRUCTURAL ENG'S NAME AND SIGNATURE	BUILDER NAME AND SIGNATURE	DIGITAL SIGNATURE
RAJEEV RANJAN SINGH MADA/ENG/0004/2019			

Proposal Basic Information	
Proposal File No.	MADA/BP/0031/2019
Owner Name	SRI ARUN KUMAR SHARMA
Khata No	24, NEW-100
Plot No	330,331,332, NEW-100
Village Name	Narayanpur
Use	Residential
SubUse	Bungalow/ Dwelling / Non Apartment

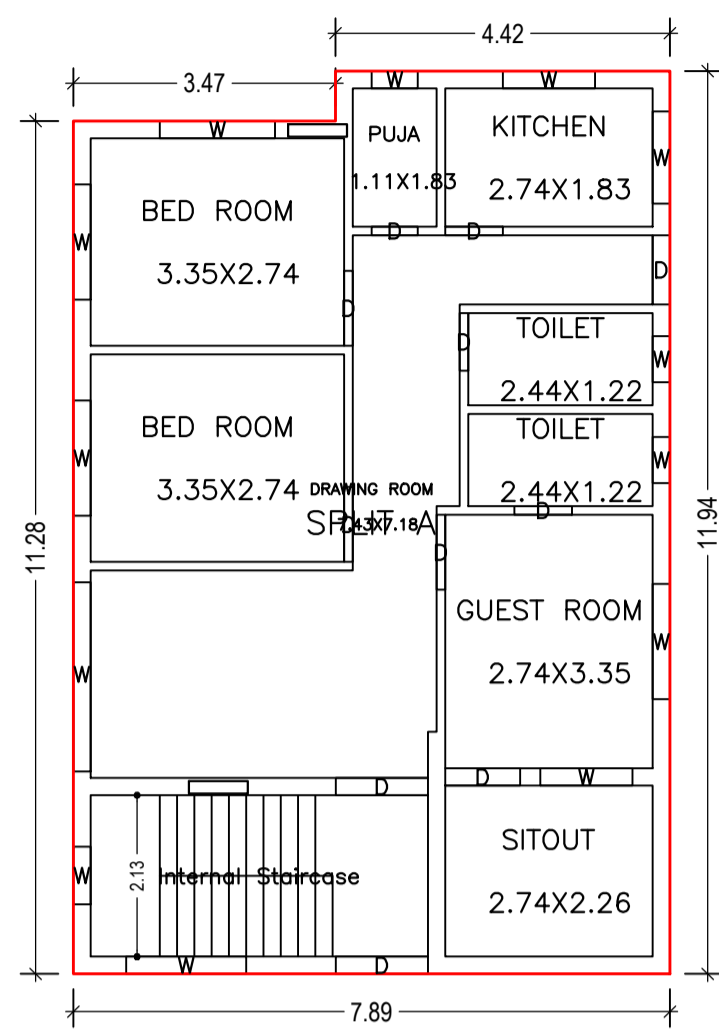

GROUND FLOOR PLAN
(Proposed)
(SCALE 1:100)

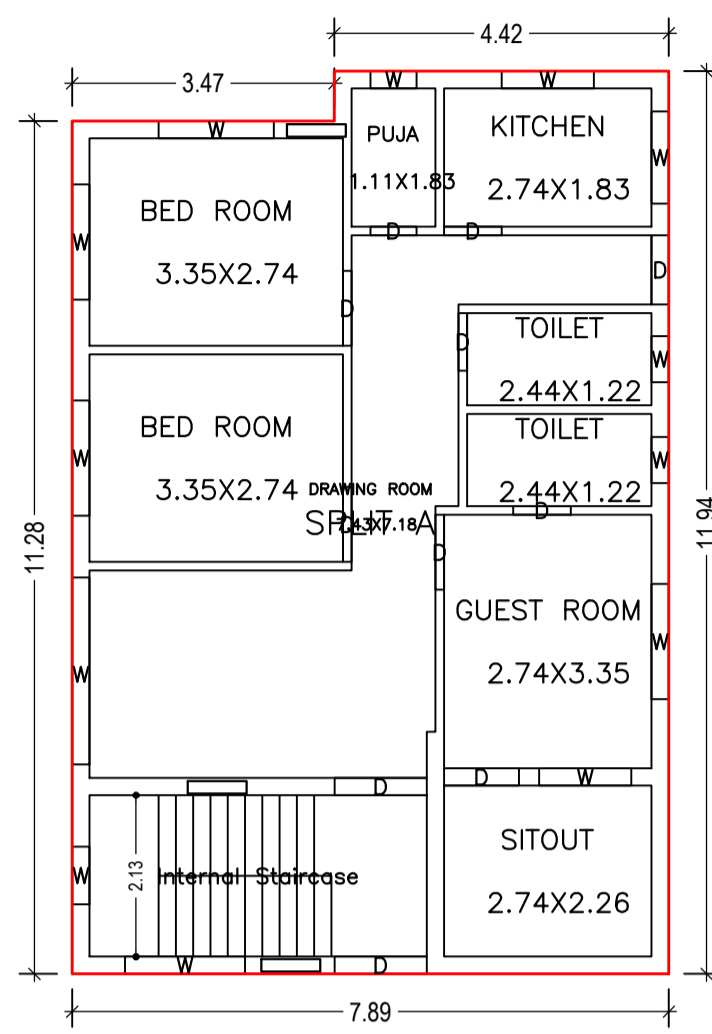

FIRST FLOOR PLAN
(Proposed)
(SCALE 1:100)

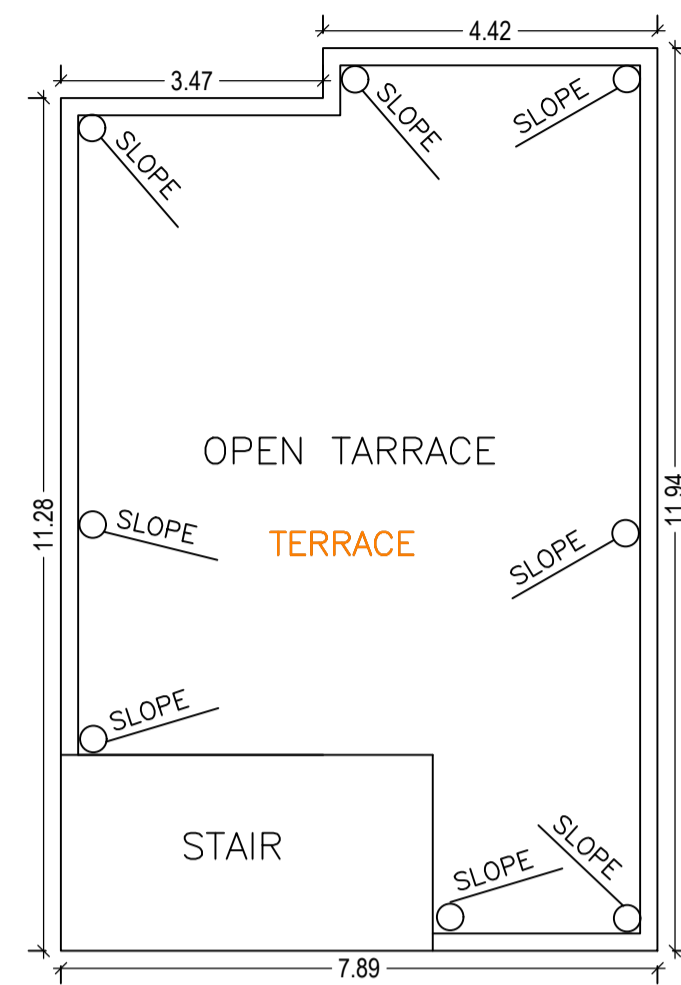

TERRACE FLOOR PLAN
(SCALE 1:100)

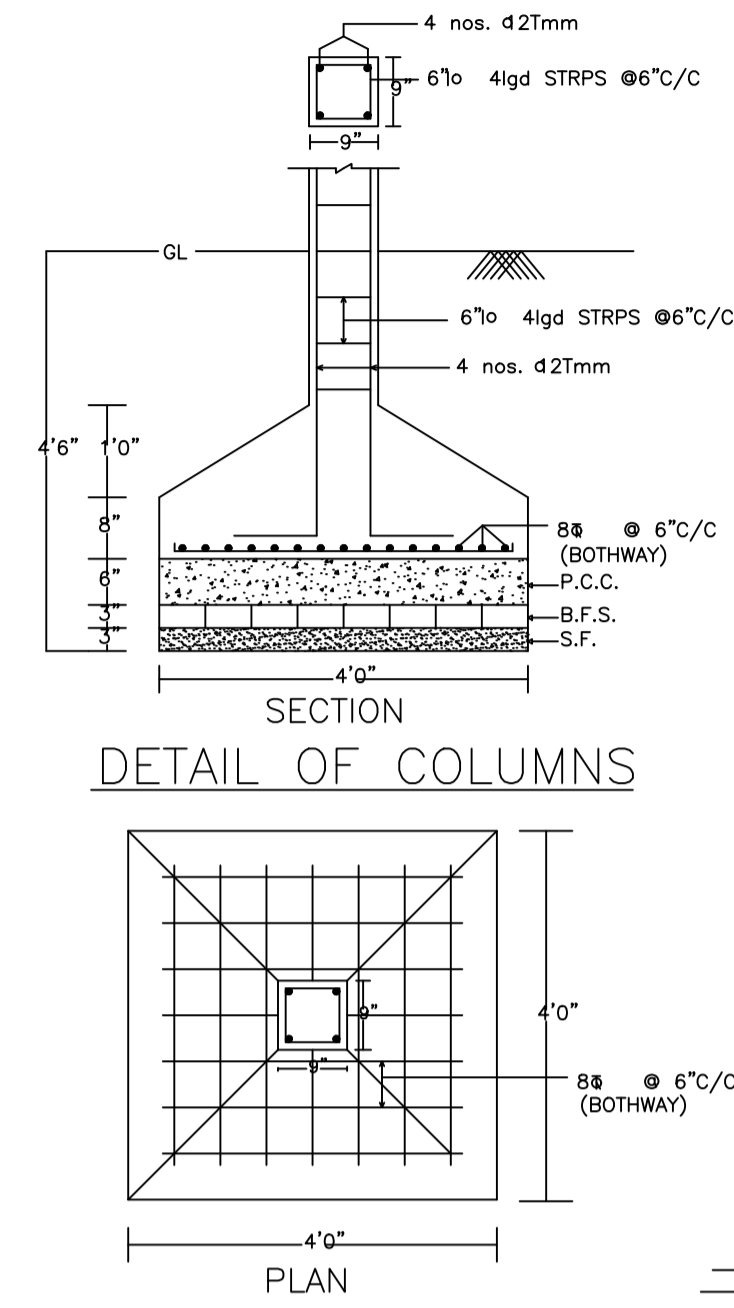

DETAIL OF BRICK FOUNDATION:-
SCALE:- 1" = 2' - 0"

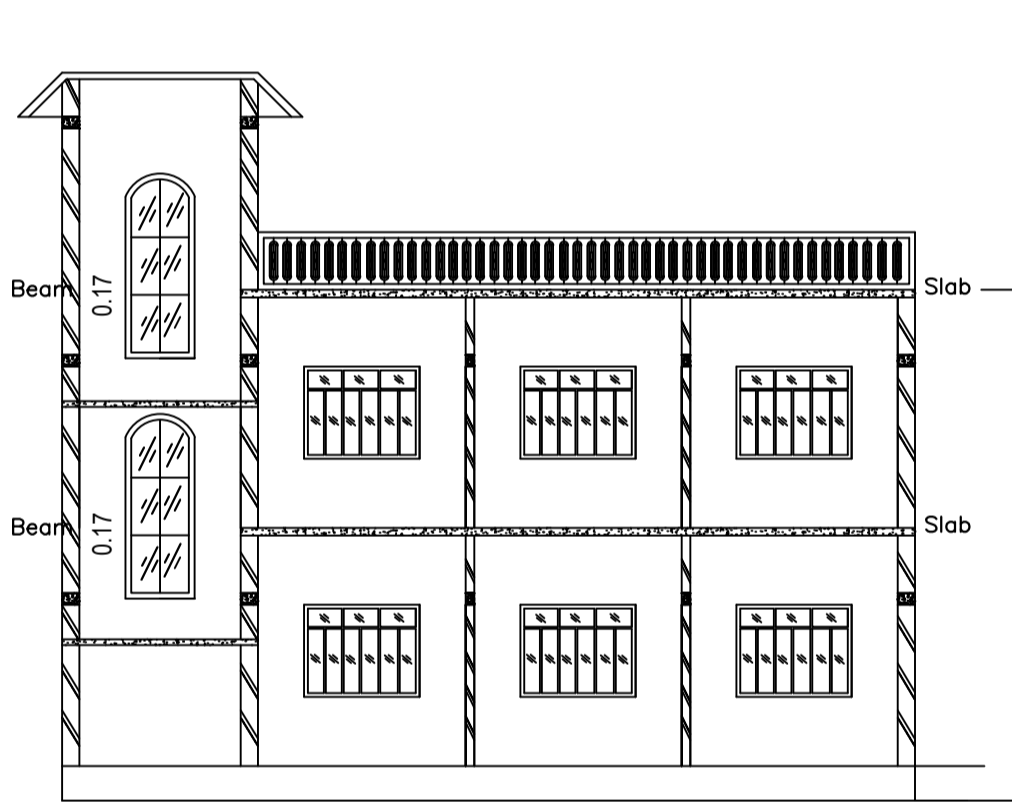

SECTION AT X-X
SCALE - 1" = 8' - 0"

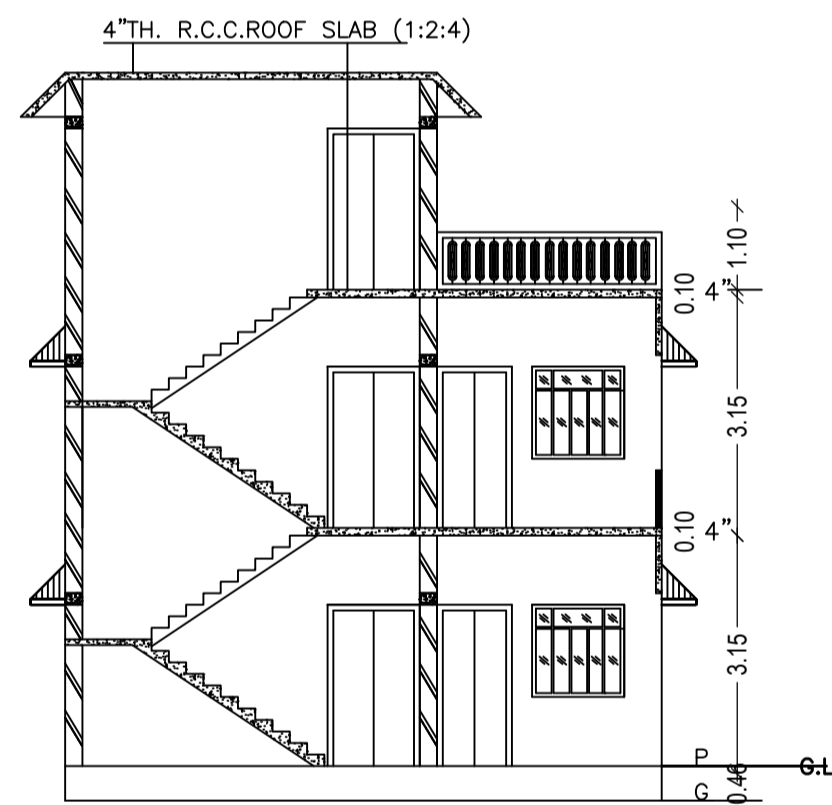

SECTION AT Y-Y
SCALE - 1" = 8' - 0"

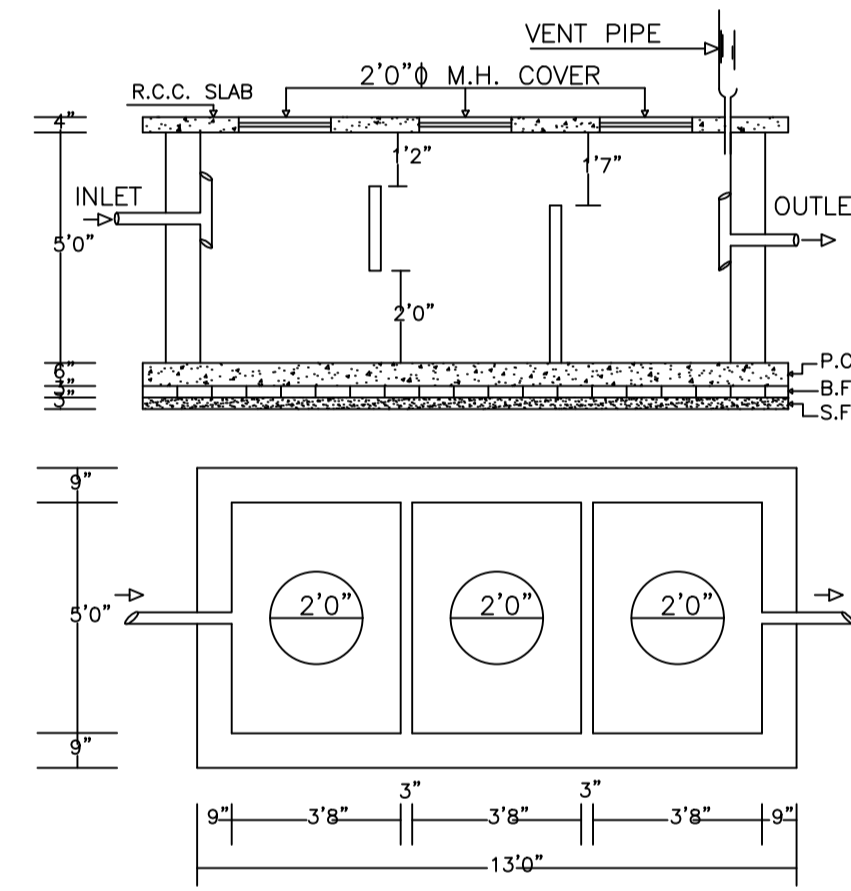

PLAN OF SEPTIC TANK
SCALE:- 1" = 4' - 0"

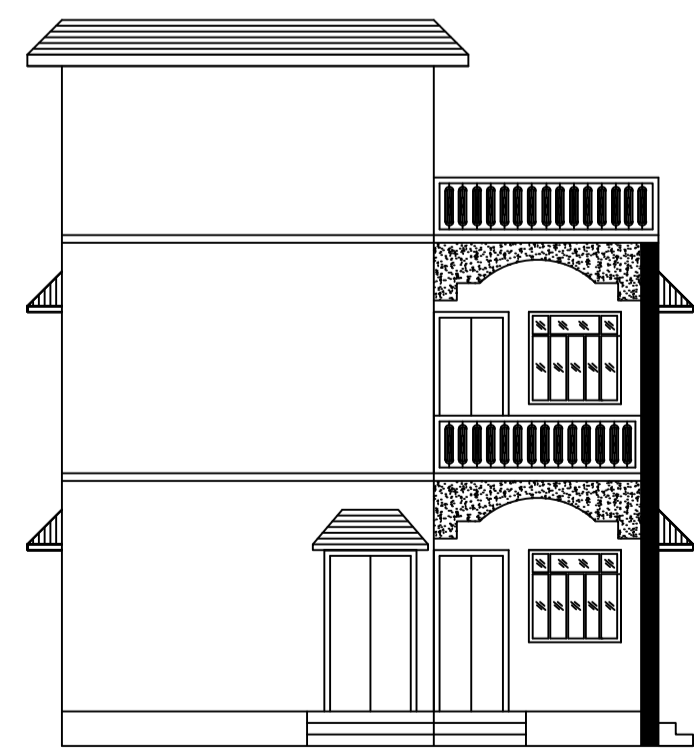
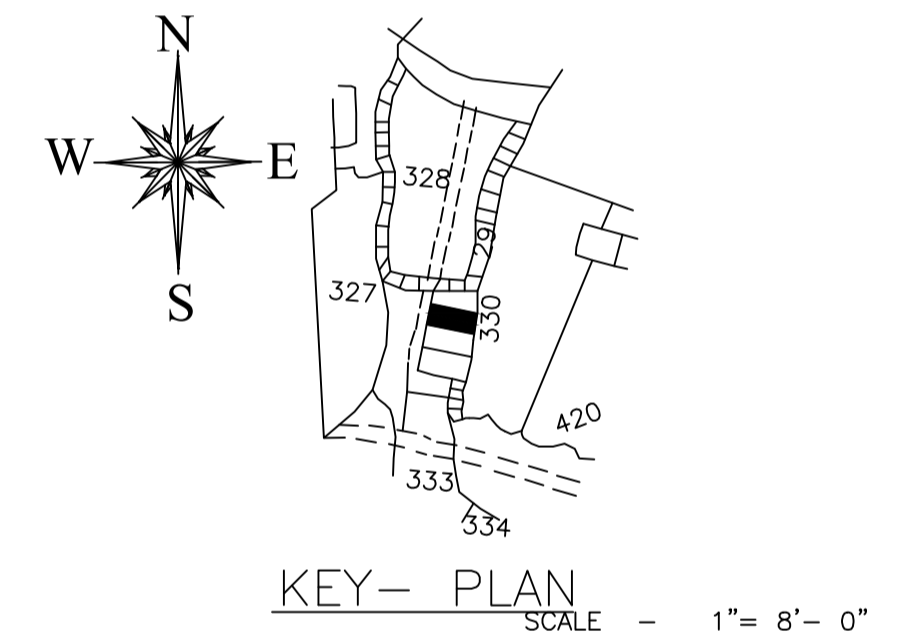

FRONT ELEVATION
SCALE - 1" = 8' - 0"

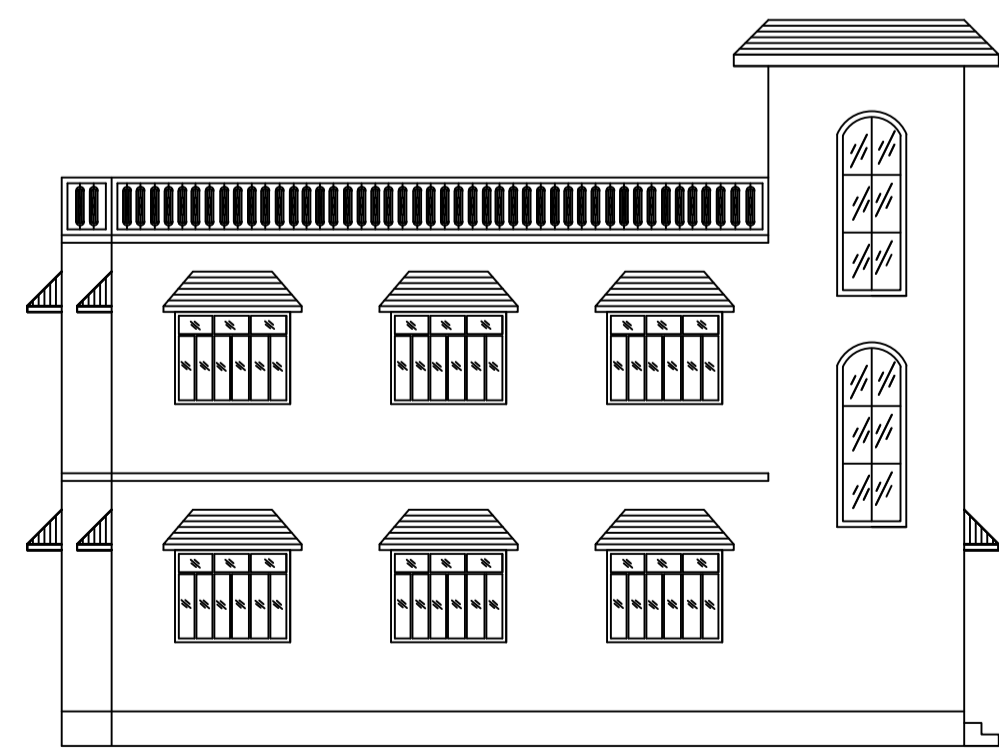

LEFT SIDE ELEVATION
SCALE - 1" = 8' - 0"

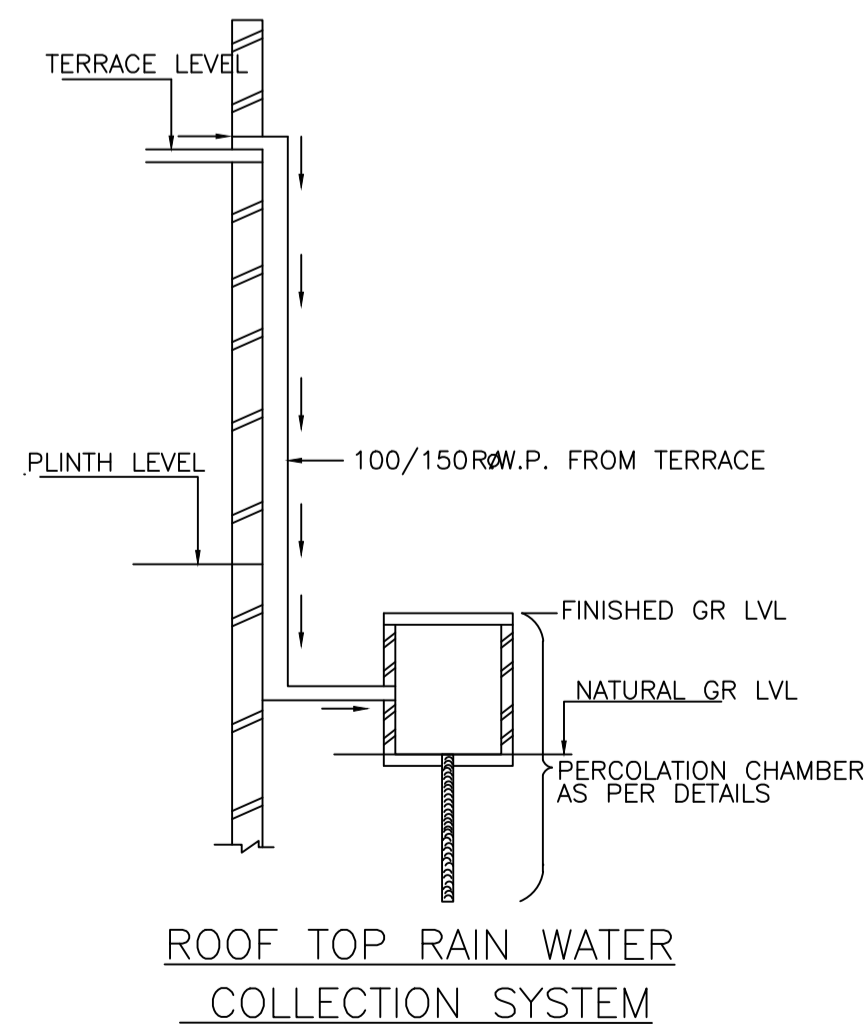

ROOF TOP RAIN WATER
COLLECTION SYSTEM

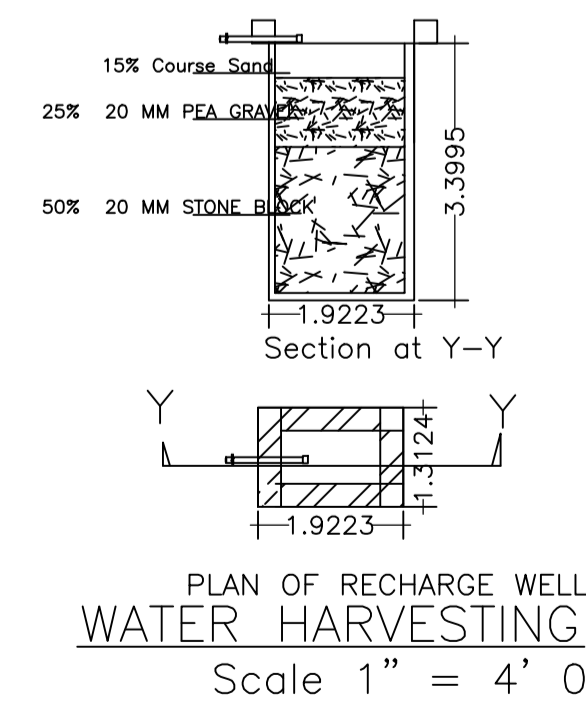

PLAN OF RECHARGE WELL
WATER HARVESTING
Scale 1" = 4' 0"

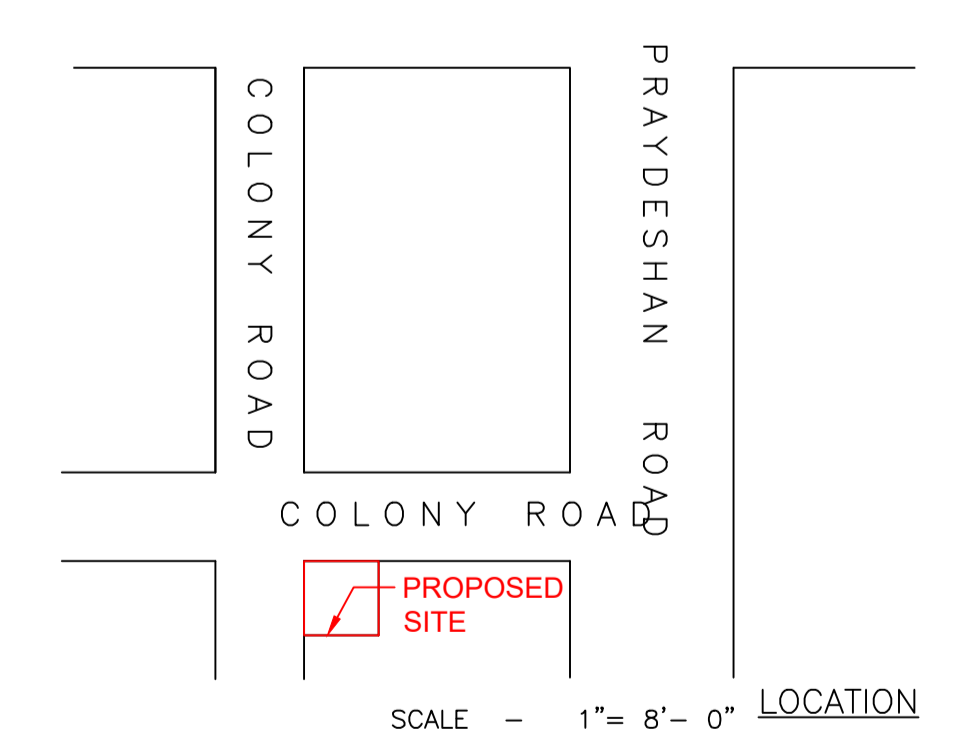

LTP NAME AND SIGNATURE	STRUCTURAL ENG'S NAME AND SIGNATURE	BUILDER NAME AND SIGNATURE	DIGITAL SIGNATURE
RAJEEV RANJAN SINGH MADA/ENG/0004/2019			