

SITE PLAN
SCALE :- 1 IN = 200

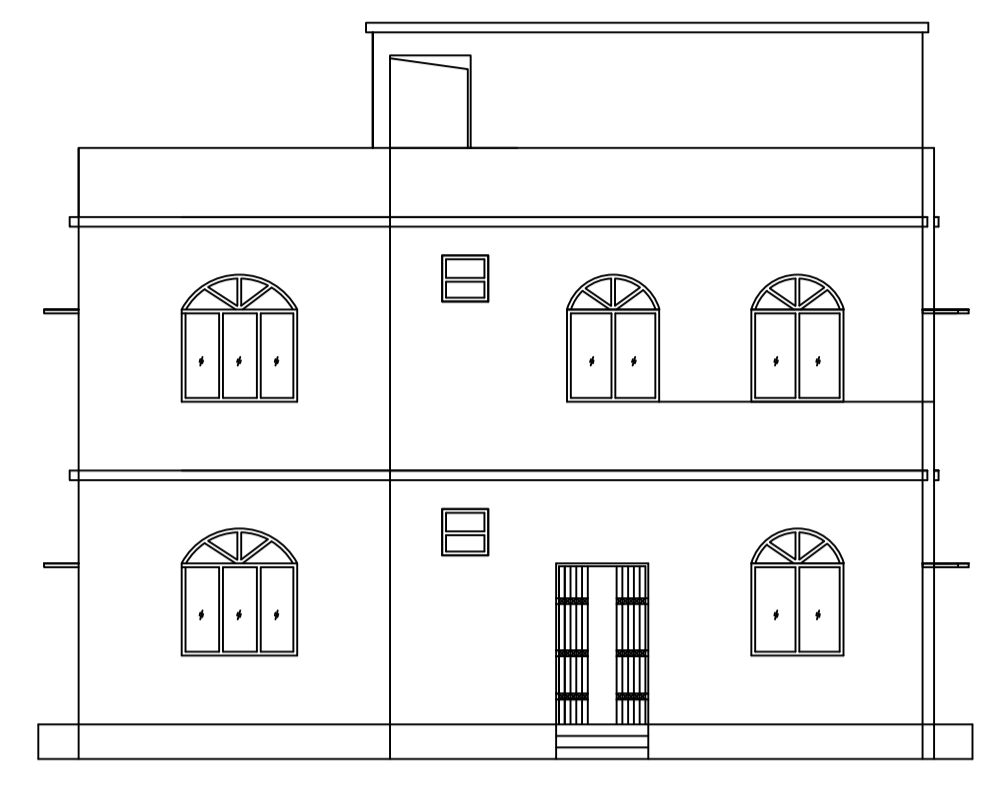

FRONT ELEVATION

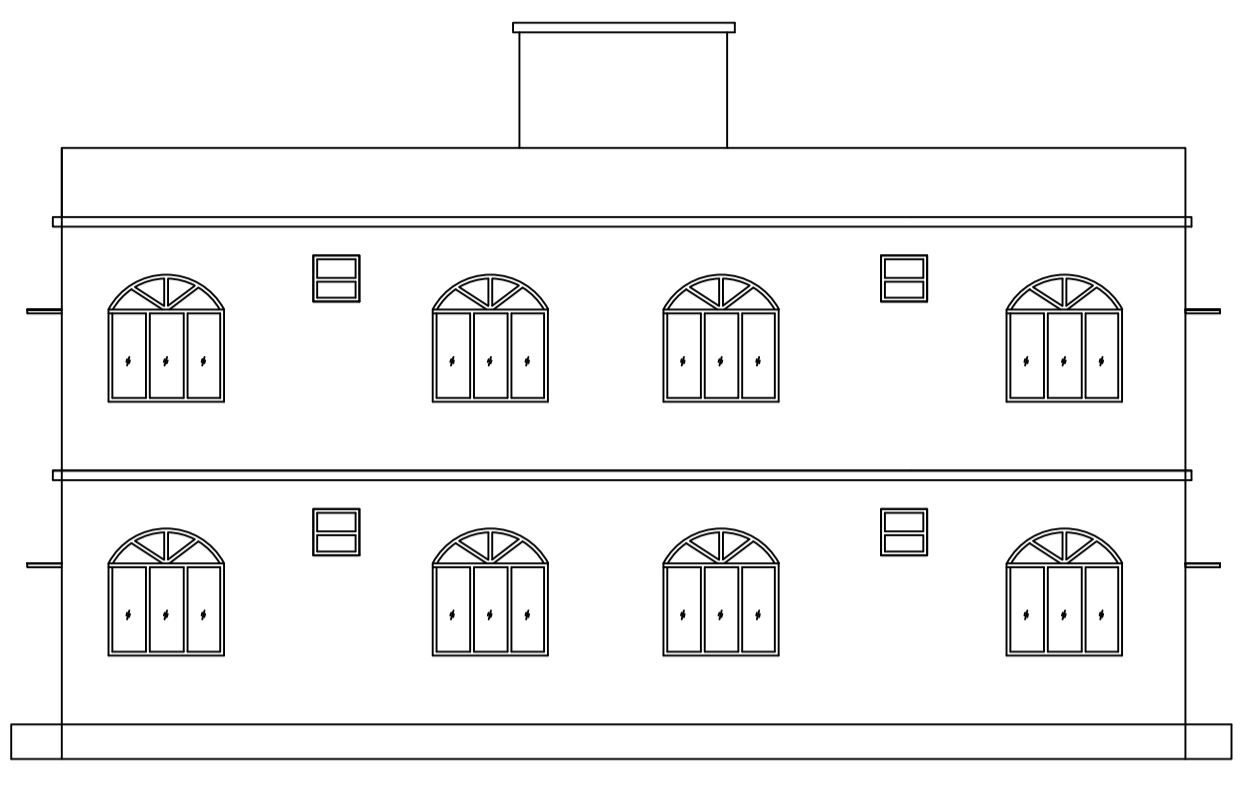

LEFT SIDE ELEVATION

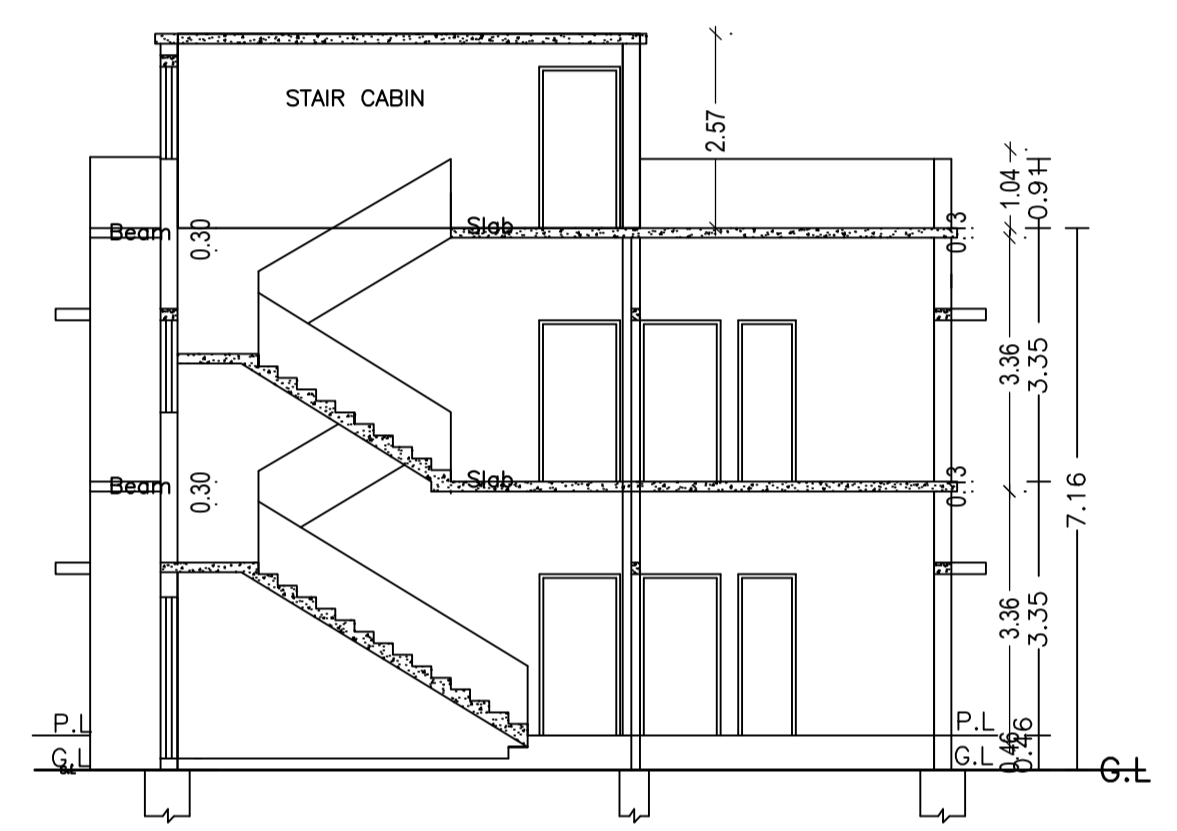

SECTION AT X-X

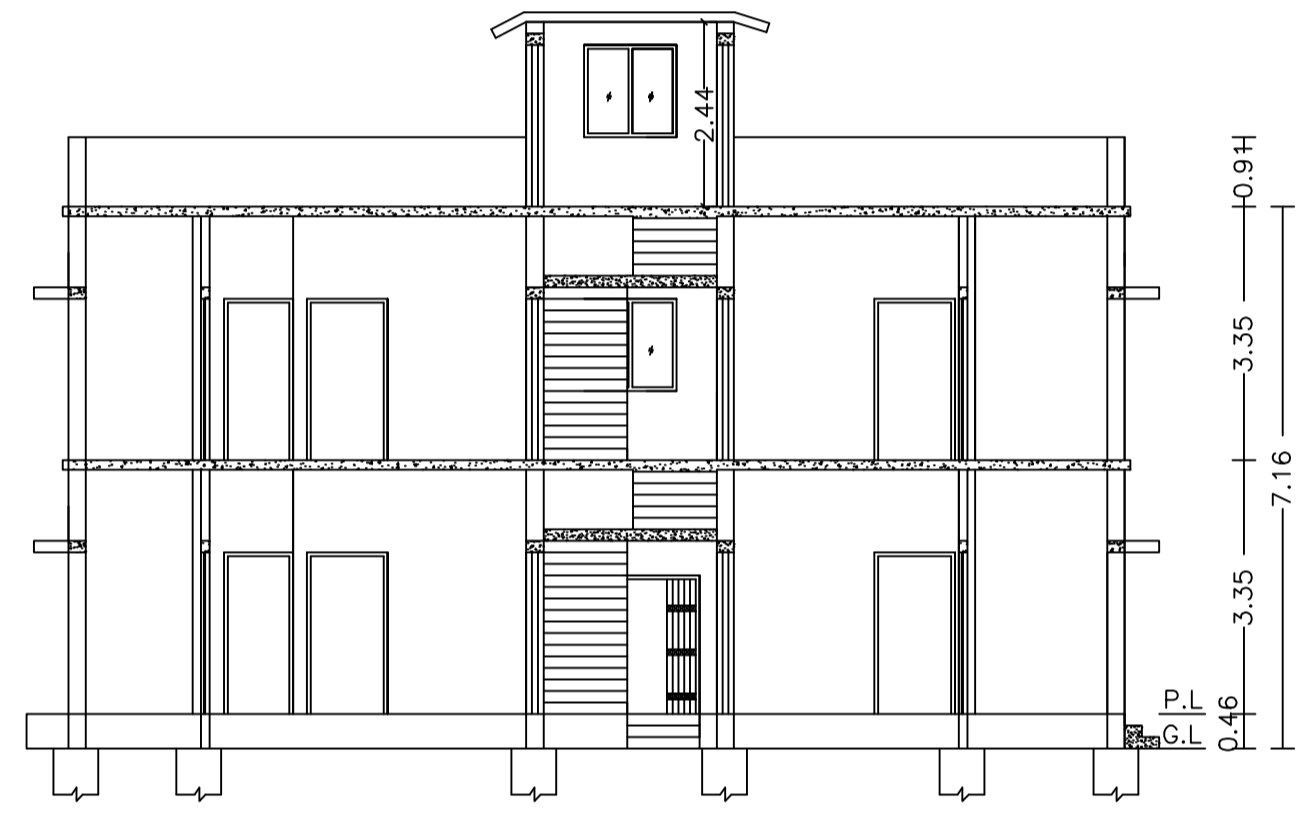

SECTION AT Y-Y

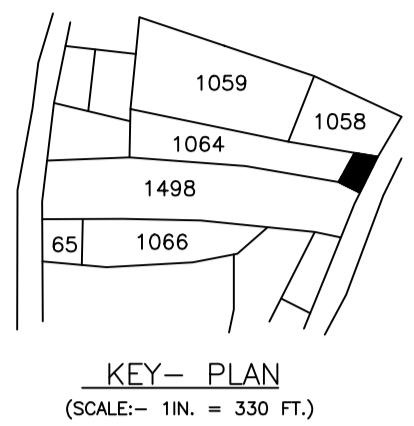

KEY- PLAN
(SCALE:- 1IN. = 330 FT.)

Proposal Basic Information	
Proposal File No.	MADA/BP/0016/2019
Owner Name	SRI. ARBIND PRASAD SINGH.
Khata No	81 (Old), 242 (New)
Plot No	1064 (Old), 866 (New)
Village Name	Nawadh
Use	Residential
SubUse	Bungalow/ Dwelling / Non Apartment

AREA STATEMENT MINERAL AREA DEVELOPMENT AUTHORITY		VERSION NO. : 1.0.43
PROJECT DETAIL:		VERSION DATE: 29/04/2019
Region: JHARKHAND URBAN LOCAL BODIES	District: DHANBAD	Plot Use: Residential
Authority: MINERAL AREA DEVELOPMENT AUTHORITY	Inward No: MADA/BP/0016/2019	Plot SubUse: Bungalow/ Dwelling / Non Apartment
Application Type: General Proposal	Project Type: Building Permission	PlotNearby/ReligiousStructure: NA
Nature of Development: New	Location of Development Area: Old Area	Plot/SubPlot No: 1064 (Old), 866 (New)
Area Details:		North: Plot No. - PLOT NO - 1058
AREA OF PLOT (Minimum)	(A)	South: Road Width - 3.65
NET AREA OF PLOT (Gross Plot Area - Deduction from Gross Plot area)	(A-Deductions)	East: Plot No. - PLOT NO - 1072
		West: Plot No. - PART OF THIS PLOT
Deduction for Balance Plot Area (from Gross Plot Area)		
Common Plot		
Total		30.30
BALANCE AREA OF PLOT (Net Plot Area - Recreational/Amenity space)	(A-Deductions)	30.30
PLOT AREA FOR COVERAGE (Net Plot Area)	(A-Deductions)	234.61
Plot Area for FAR (Net Plot Area + Road Widening Area)	(A-Deductions)	264.90
		264.90
COVERAGE CHECK		
Permissible Coverage area (60.00 %)		158.94
Proposed Coverage Area (59.82 %)		158.47
Total Prop. Coverage Area (59.82 %)		158.47
Balance coverage area (0.18 %)		0.47
FAR CHECK		
Perm. FAR Area (1.50)		397.35
Total Perm. FAR area		397.35
Residential FAR		316.93
Proposed FAR Area		316.93
Total Proposed FAR Area		316.93
Consumed FAR (Factor)		1.20
Balance FAR Area		80.42
BUILT UP AREA CHECK		
Total Proposed BuiltUp Area		316.94
ARCHITECT (Regd)	Partha Pal	
ENGINEER (Regd)		
SUPERVISOR (Regd)		
OWNER (Regd)	SRI. ARBIND PRASAD SINGH.	
DEVELOPMENT AUTHORITY		LOCAL BODY

COLOR INDEX	
PLOT BOUNDARY	Black
ABUTTING ROAD	Red
PROPOSED CONSTRUCTION	Green
COMMON PLOT	Yellow
ROAD WIDENING AREA	Blue
EXISTING (To be retained)	Orange
EXISTING (To be demolished)	Light Blue

SITE PLAN

SCHEDULE OF DOOR:					
BUILDING NAME	NAME	LENGTH	HEIGHT	NOS	
A (1)	D2	0.76	2.10	08	
A (1)	D1	0.92	2.10	04	
A (1)	D	1.01	2.10	02	
A (1)	D	1.05	2.10	02	
A (1)	D	1.07	2.10	12	

SCHEDULE OF WINDOW/VENTILATION:					
BUILDING NAME	NAME	LENGTH	HEIGHT	NOS	
A (1)	V	0.61	1.20	08	
A (1)	W1	1.22	1.20	05	
A (1)	W	1.53	1.20	18	

Building : A (1)					
Floor Name	Total Built Up Area (Sq.mt.)	Proposed FAR Area (Sq.mt.) Res.	Total FAR Area (Sq.mt.)	Total Consumed Additional FAR Area (Sq.mt.)	Tnmt (No.)
Ground Floor	158.47	158.47	158.47	158.47	01
First Floor	158.47	158.47	158.47	158.47	00
Terrace Floor	0.00	0.00	0.00	0.00	00
Total :	316.94	316.94	316.94	316.94	01
Total Number of Same Buildings :	1				
Total :	316.94	316.94	316.94	316.94	01

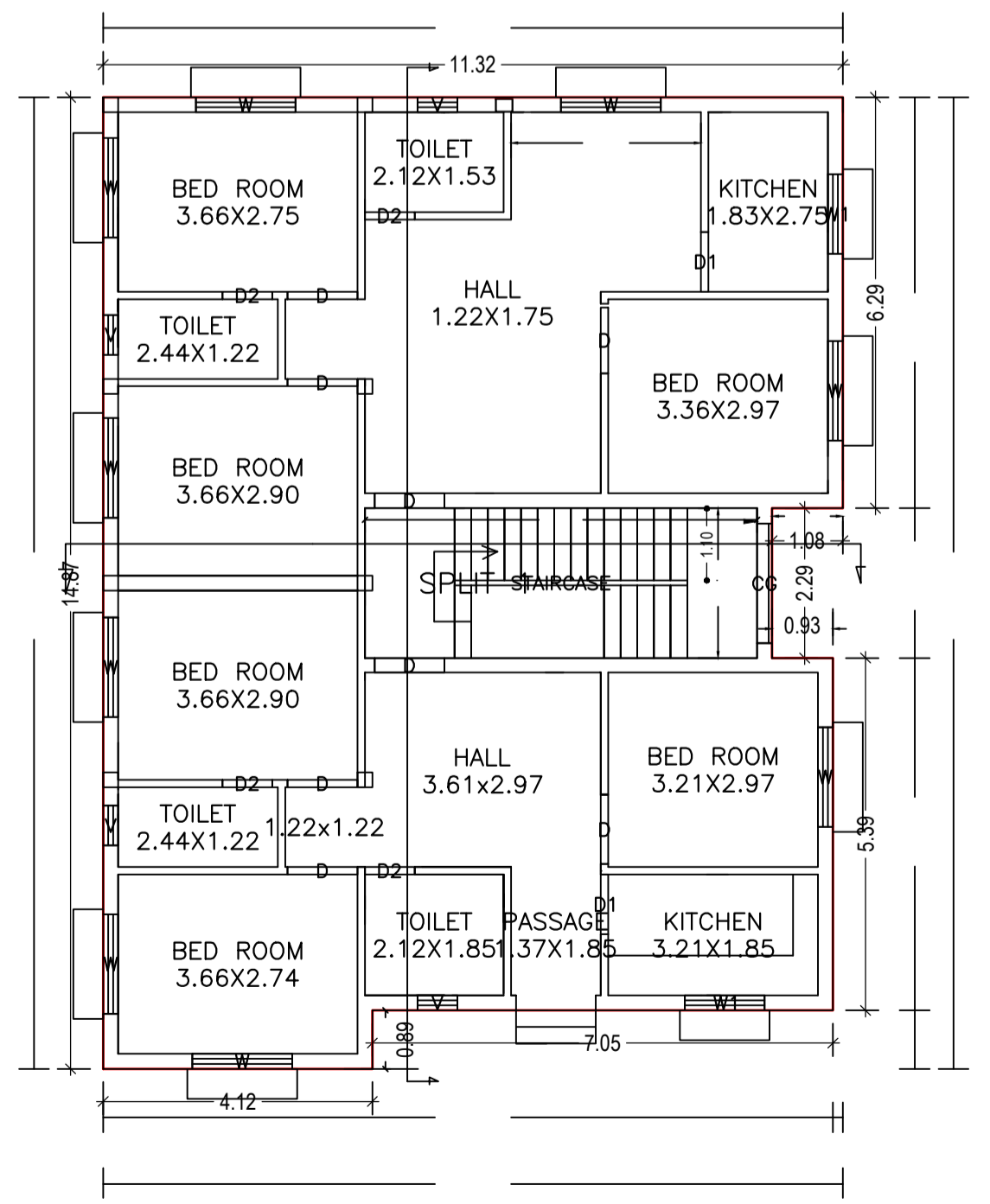

GROUND FLOOR PLAN (Proposed)
(SCALE 1:100)

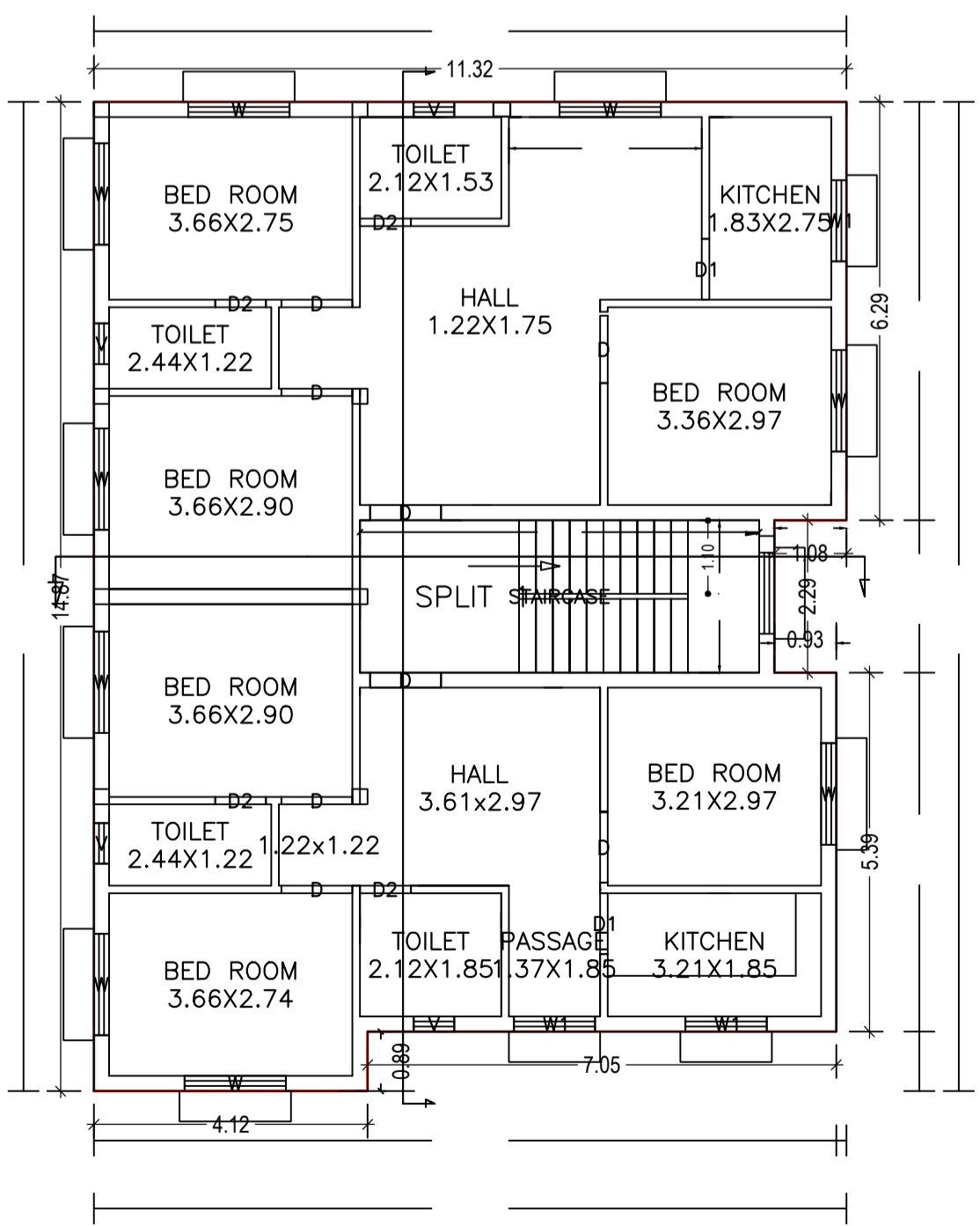

FIRST FLOOR PLAN (Proposed)
(SCALE 1:100)

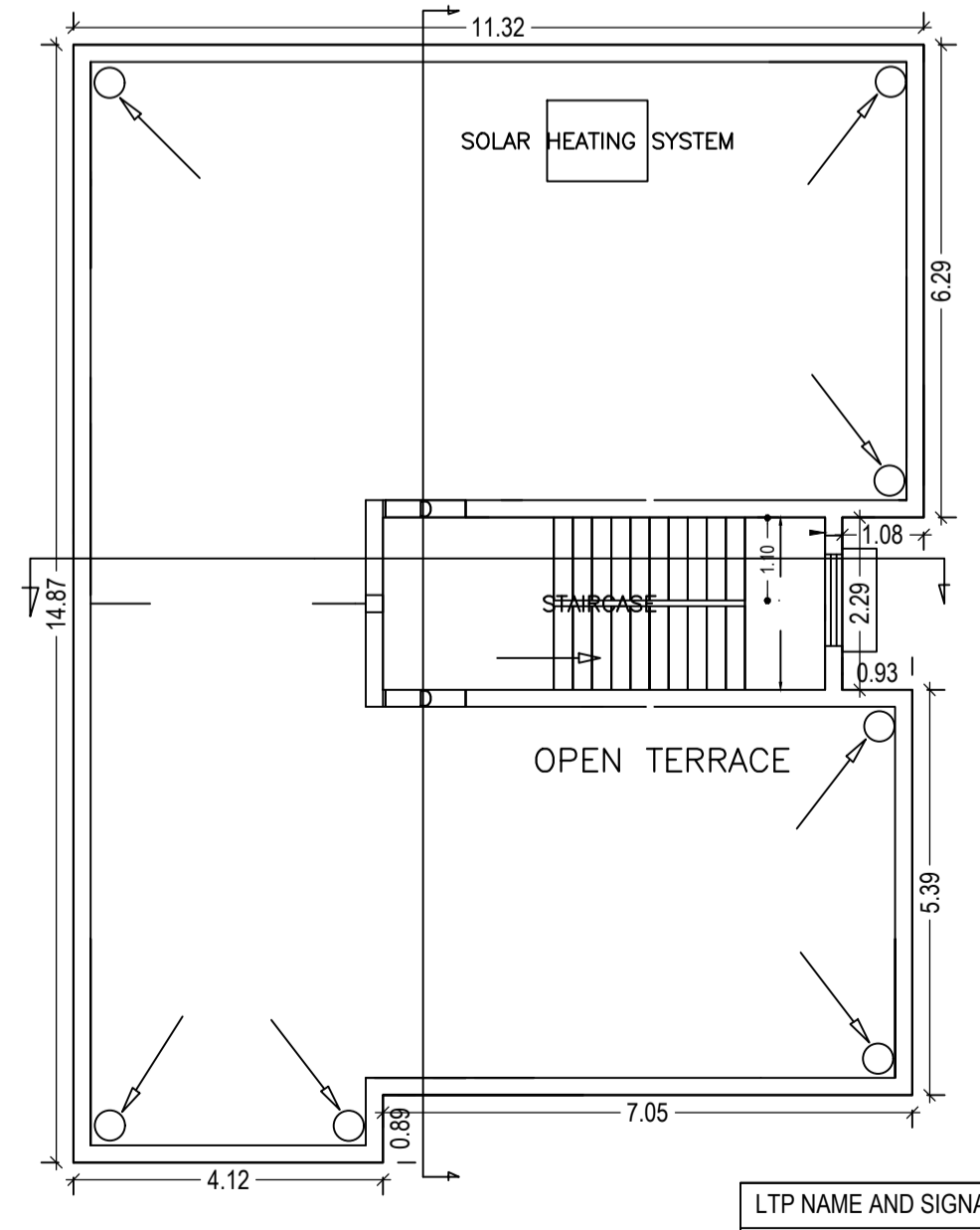

TERRACE FLOOR PLAN (SCALE 1:100)

Floor Name	Building Name A (1)		Total	
	Proposed Built Up Area (Sq.mt.)	Proposed FAR Area (Sq.mt.)	Total Proposed Built Up Area (Sq.mt.)	Total FAR Area (Sq.mt.)
Ground Floor	158.47	158.47	158.47	158.47
First Floor	158.47	158.47	158.47	158.47
Terrace Floor	0.00	0.00	0.00	0.00
Total :	316.94	316.94	316.94	316.94

Building USE/SUBUSE Details			
Building Name	Building Use	Building SubUse	Building Structure
A (1)	Residential	Residential Bldg/Apartment	Non-Highrise

FAR & Tenement Details (Table 4c-1)						
Building	No. of Same Bldg	Total Built Up Area (Sq.mt.)	Proposed FAR Area (Sq.mt.) Res.	Total FAR Area (Sq.mt.)	Total Consumed Additional FAR Area (Sq.mt.)	Tnmt (No.)
A (1)	1	316.94	316.94	316.94	316.94	01
Grand Total :	1	316.94	316.94	316.94	316.94	01

UnitBUA Table for Building : A (1)						
FLOOR	Name	UnitBUA Type	UnitBUA Area	Carpet Area	No. of Rooms	No. of Tenement
GROUND FLOOR PLAN	SPLIT 1	FLAT	316.93	316.83	15	1
FIRST FLOOR PLAN	SPLIT 1	FLAT	0.00	0.00	15	0
Total:			316.93	316.83	30	1

LTP NAME AND SIGNATURE	STRUCTURAL ENG'S NAME AND SIGNATURE	BUILDER NAME AND SIGNATURE	DIGITAL SIGNATURE
Partha Pal MADA/ENG/0002/2019			

Proposal Basic Information	
Proposal File No.	MADA/BP/0016/2019
Owner Name	SRI. ARBIND PRASAD SINGH.
Khata No	81 (Old), 242 (New)
Plot No	1064 (Old), 866 (New)
Village Name	Nawadhi
Use	Residential
SubUse	Bungalow/ Dwelling / Non Apartment

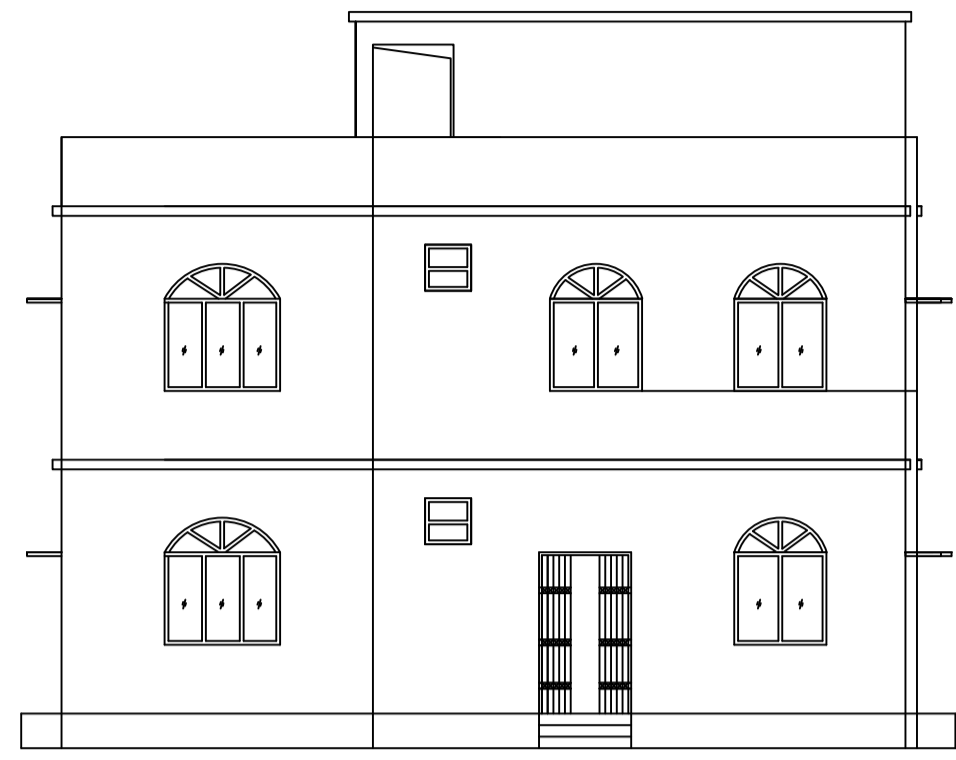

FRONT ELEVATION

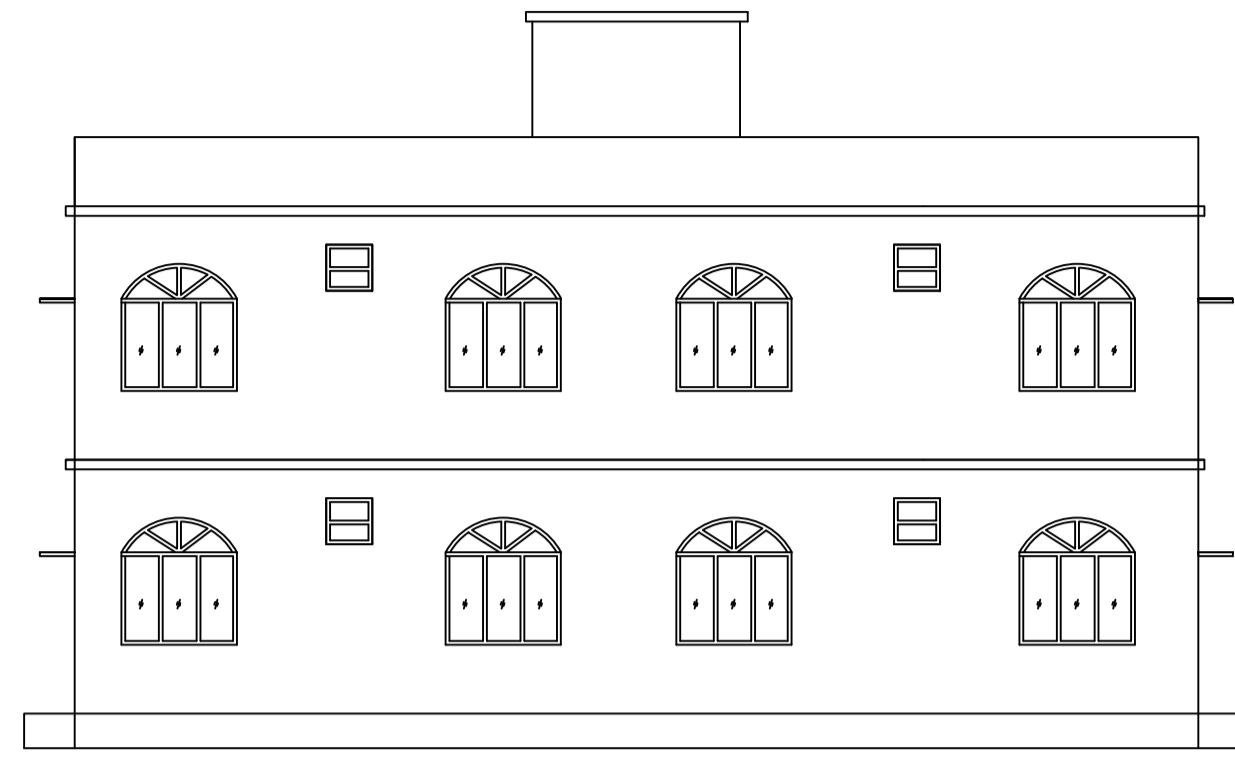

LEFT SIDE ELEVATION

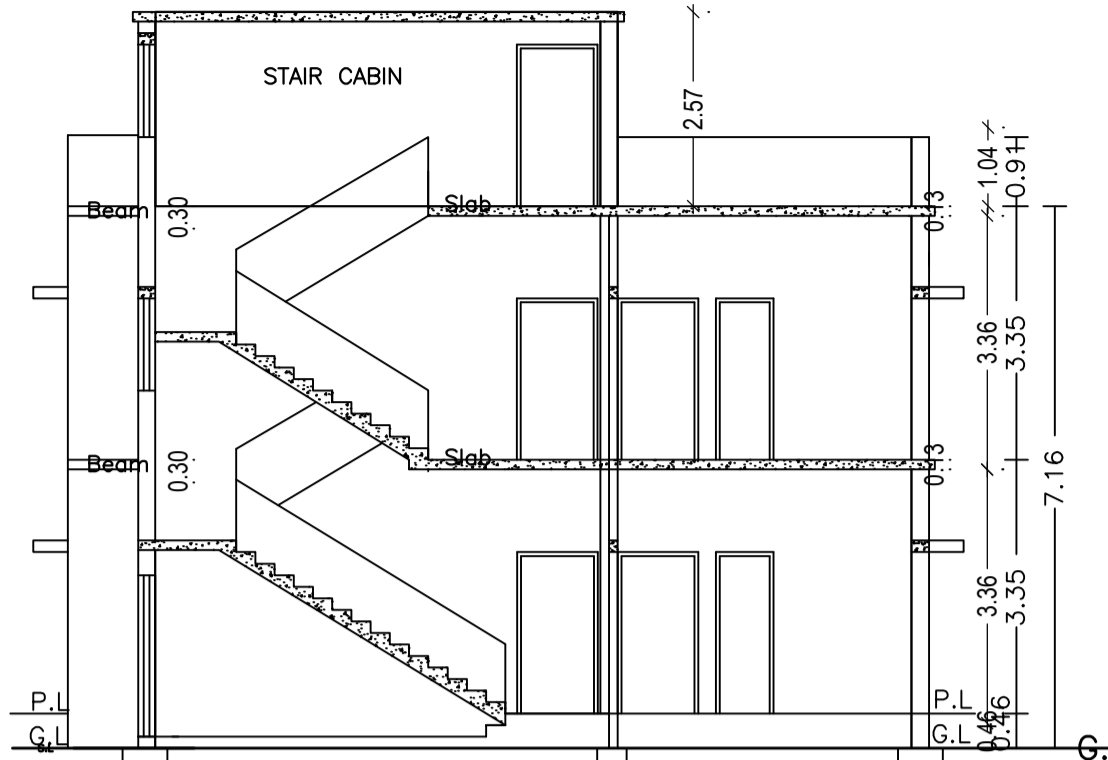

SECTION AT X-X

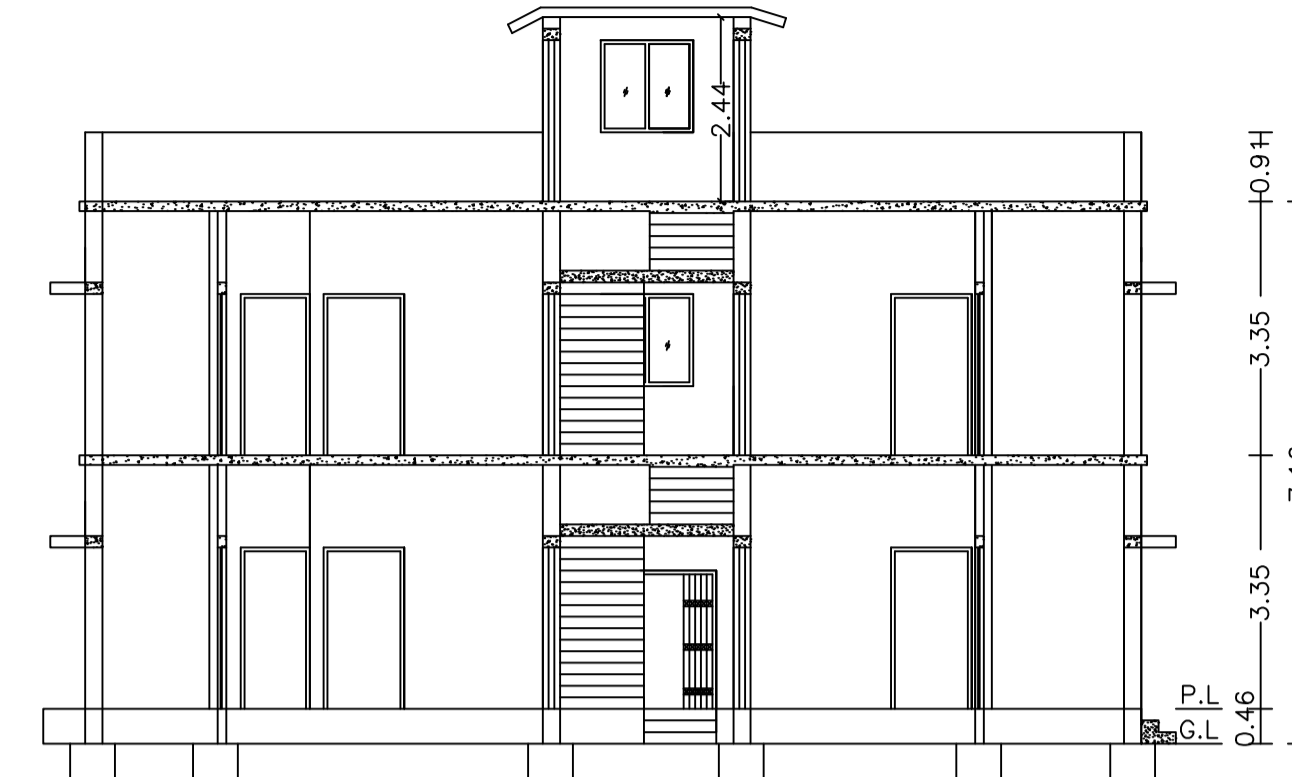

SECTION AT Y-Y

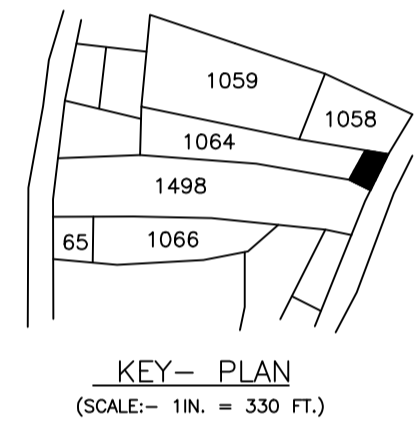

KEY- PLAN
(SCALE:- 1IN. = 330 FT.)

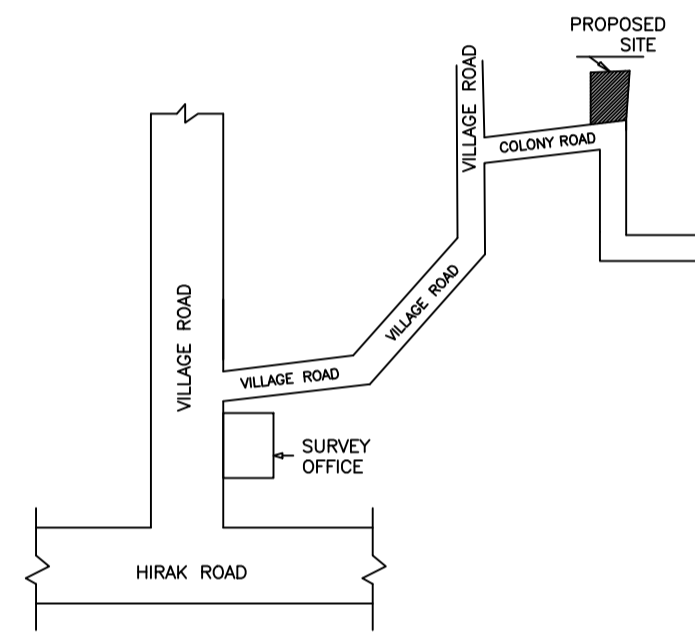

LOCATION PLAN
NOT TO SCALE

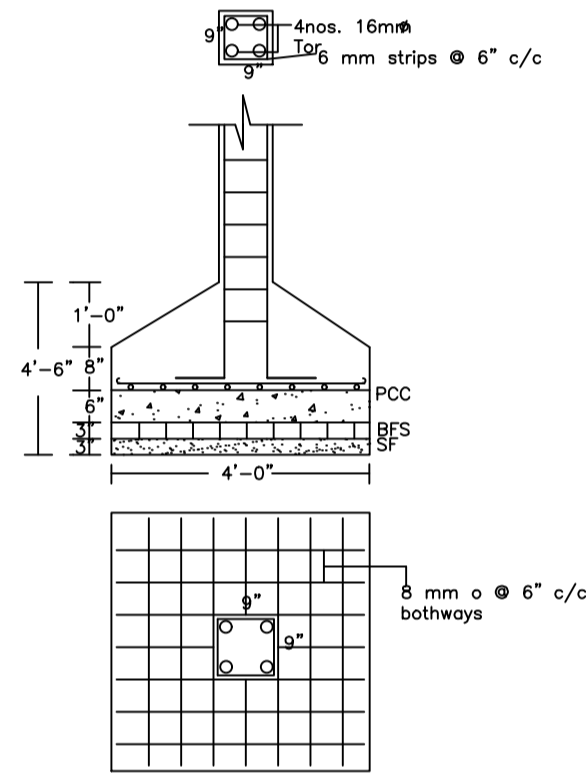

DETAILS OF COLUMNS
(SCALE:- 1IN. = 50)

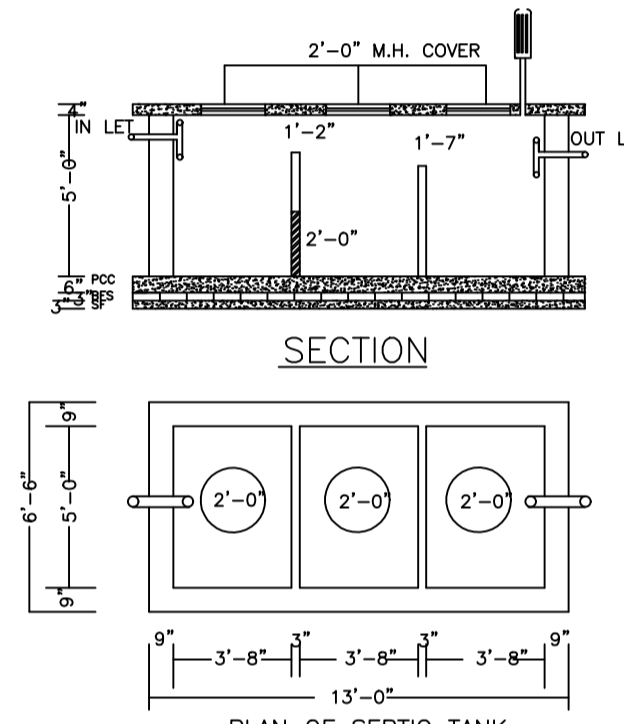

PLAN OF SEPTIC TANK
(SCALE:- 1IN. = 25.)

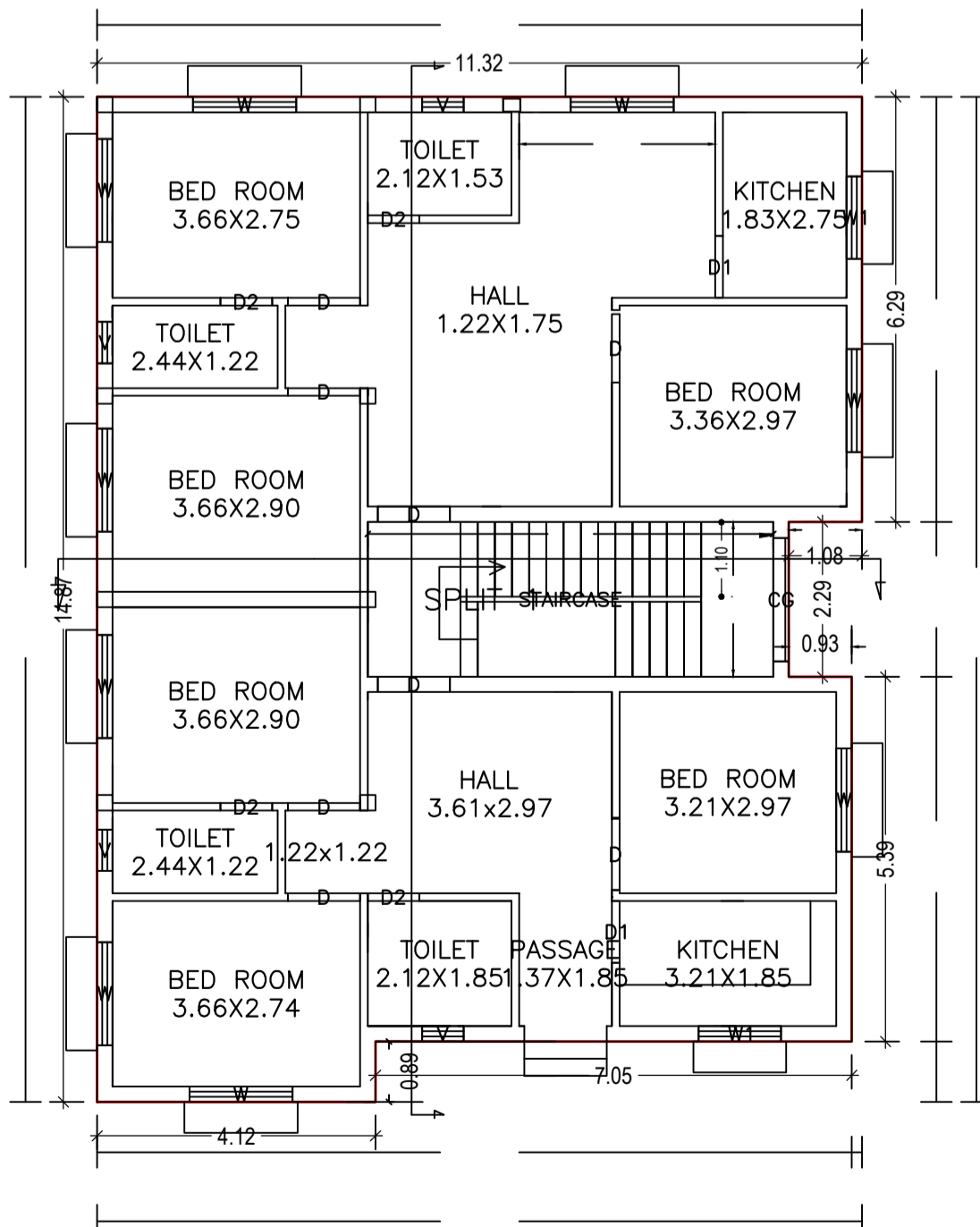

GROUND FLOOR PLAN
(Proposed)
(SCALE 1:100)

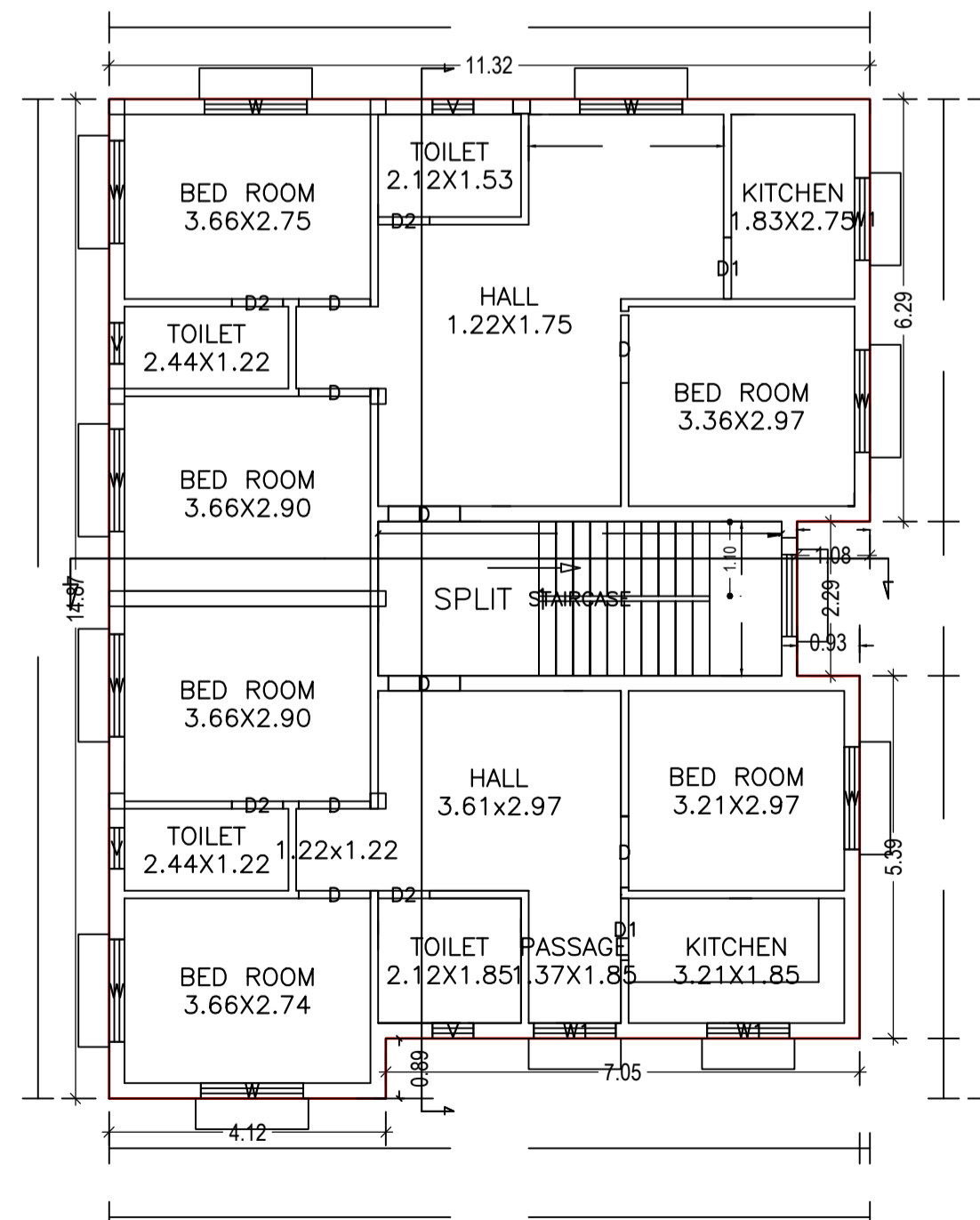

FIRST FLOOR PLAN
(Proposed)
(SCALE 1:100)

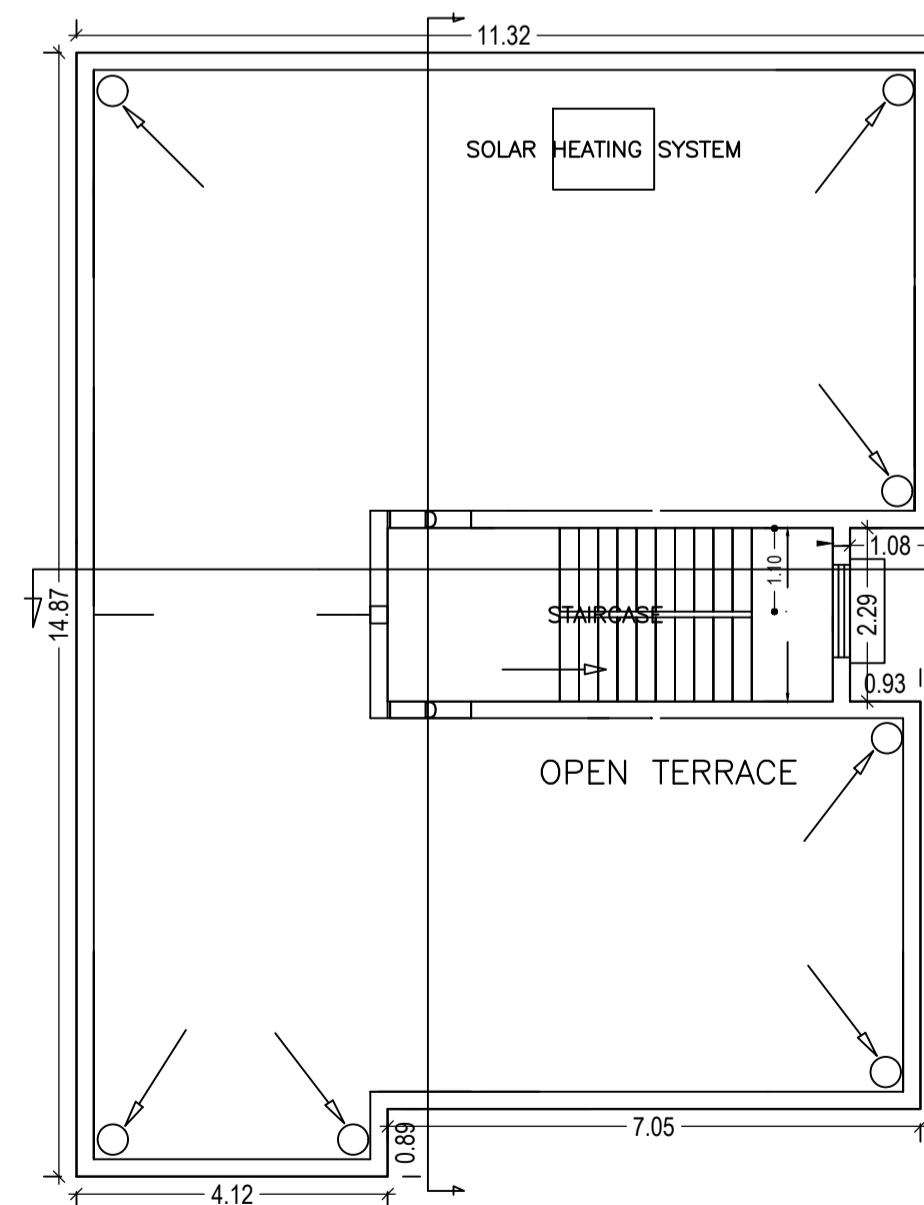

TERRACE FLOOR PLAN
(SCALE 1:100)

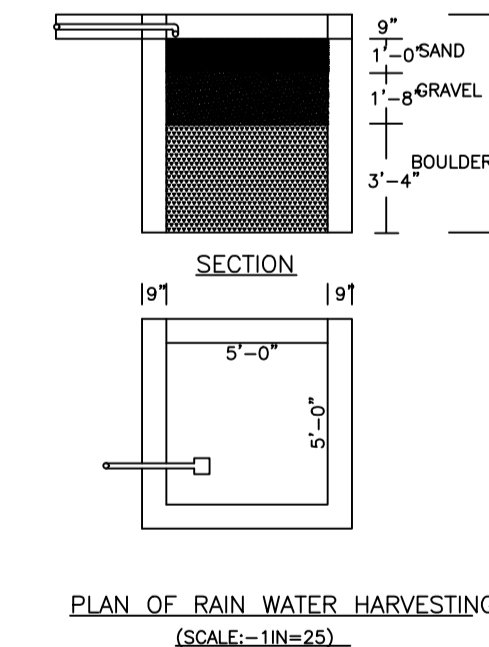

PLAN OF RAIN WATER HARVESTING
(SCALE:- 1IN. = 25.)

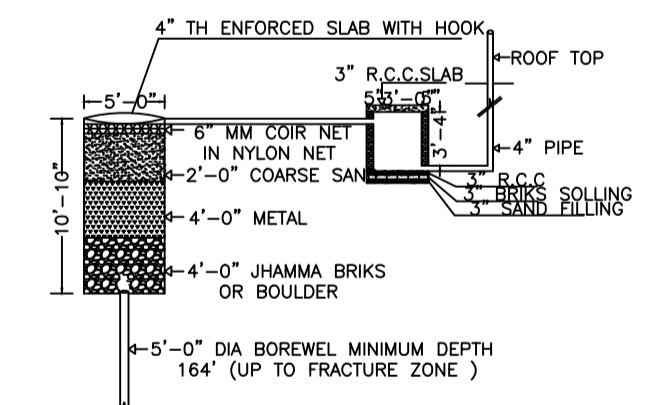

DETAIL OF GROUND WATER RECHARGING PIT WITH SILT TANK
NOT TO SCALE

LTP NAME AND SIGNATURE	STRUCTURAL ENG'S NAME AND SIGNATURE	BUILDER NAME AND SIGNATURE	DIGITAL SIGNATURE
Partha Pal MADA/ENG/0002/2019			