

Location Plan

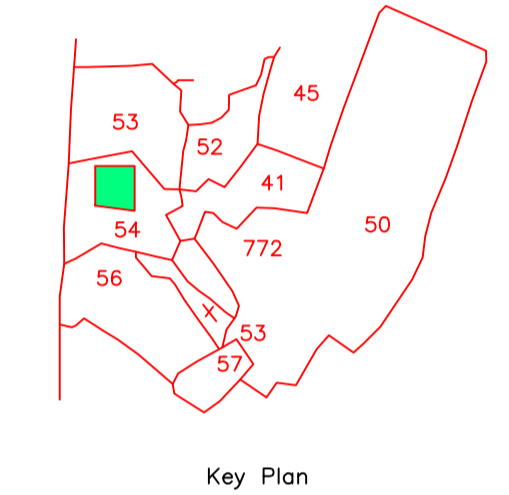

Proposal Basic Information

Proposal File No.	MADA/BP/0003/2019
Owner Name	SRI JAY PRAKASH MISHRA, SMT SUNITA MISHRA
Khata No	OLD-01,11, NEW-17,55
Plot No	OLD-126,132, NEW-52,54
Village Name	Narayanpur
Use	Residential
SubUse	Bungalow/ Dwelling / Non Apartment

AREA STATEMENT MINERAL AREA DEVELOPMENT AUTHORITY	VERSION NO.: 1.0.42	SQ.MT.
PROJECT DETAIL:	Plot Use: Residential	
Region: JHARKHAND URBAN LOCAL BODIES	Plot SubUse: Bungalow/ Dwelling / Non Apartment	
District: DHANBAD	PlotNearbyReligiousStructure: NA	
Authority: MINERAL AREA DEVELOPMENT AUTHORITY	Plot/Plot No: OLD-126,132, NEW-52,54	
Inward No: MADA/BP/0003/2019	North: Plot No. - 126	
Application Type: General Proposal	South: Plot No. - SELLER'S NIZ	
Project Type: Building Permission	East: Road Width - 4.57	
Nature of Development: New	West: Road Width - 4.57	
Location of Development Area: Old Area		
AREA DETAILS:		
AREA OF PLOT (Minimum)	(A)	375.02
NET AREA OF PLOT(Gross Plot Area - Deduction from Gross Plot area)	(A-Deductions)	375.02
Deduction for Balance Plot Area(from Gross Plot Area)		
Common Plot		74.24
Total		74.24
BALANCE AREA OF PLOT (Net Plot Area - Recreational/Amenity space)	(A-Deductions)	300.78
PLOT AREA FOR COVERAGE(Net Plot Area)	(A-Deductions)	375.02
Plot Area for FAR (Net Plot Area + RoadWidening Area)	(A-Deductions)	375.02
COVERAGE CHECK		
Permissible Coverage area (60.00 %)		225.01
Proposed Coverage Area (54.64 %)		204.91
Total Prop. Coverage Area (54.64 %)		204.91
Balance coverage area (5.36 %)		20.10
FAR CHECK		
Perm. FAR Area (1.50)		562.53
Total Perm. FAR area		562.53
Residential FAR		409.82
Proposed FAR Area		409.82
Total Proposed FAR Area		409.82
Consumed FAR (Factor)		1.09
Balance FAR Area		152.71
BUILT UP AREA CHECK		
Total Proposed BuiltUp Area		409.82
ARCHITECT (Regd)	RAJEEV RANJAN SINGH	
ENGINEER (Regd)		
SUPERVISOR (Regd)		
OWNER (Regd)	SRI JAY PRAKASH MISHRA, SMT SUNITA MISHRA	
DEVELOPMENT AUTHORITY	LOCAL BODY	

Building :A (SRI JAY PRAKASH MISHRA, SMT SUNITA MISHRA)

Floor Name	Total Built Up Area (Sq.mt.)	Proposed FAR Area (Sq.mt.) Resi.	Total FAR Area (Sq.mt.)	Total Consumed Additional FAR Area (Sq.mt.)	Tnmt (No.)
Ground Floor	204.91	204.91	204.91	204.91	01
Terrace Floor	0.00	0.00	0.00	0.00	00
Total	409.82	409.82	409.82	409.82	01
Total Number of Same Buildings	1				
Total	409.82	409.82	409.82	409.82	01

UnitBUA Table for Building :A (SRI JAY PRAKASH MISHRA, SMT SUNITA MISHRA)

FLOOR	Name	UnitBUA Type	UnitBUA Area	Carpet Area	No. of Rooms	No. of Tenement
GROUND FLOOR PLAN	SPLIT A	FLAT	409.82	409.56	14	1
FIRST FLOOR PLAN	SPLIT A	FLAT	0.00	0.00	13	0
Total:			409.82	409.56	27	1

SCHEDULE OF WINDOW/VENTILATION:

BUILDING NAME	NAME	LENGTH	HEIGHT	NOS
A (SRI JAY PRAKASH MISHRA, SMT SUNITA MISHRA)	W	0.61	1.20	08
A (SRI JAY PRAKASH MISHRA, SMT SUNITA MISHRA)	W	1.03	1.20	02
A (SRI JAY PRAKASH MISHRA, SMT SUNITA MISHRA)	W	1.10	1.20	01
A (SRI JAY PRAKASH MISHRA, SMT SUNITA MISHRA)	W	1.15	1.20	01
A (SRI JAY PRAKASH MISHRA, SMT SUNITA MISHRA)	W	1.22	1.20	06
A (SRI JAY PRAKASH MISHRA, SMT SUNITA MISHRA)	W	1.83	1.20	09
A (SRI JAY PRAKASH MISHRA, SMT SUNITA MISHRA)	W	2.01	1.20	01
A (SRI JAY PRAKASH MISHRA, SMT SUNITA MISHRA)	W	2.35	1.20	01
A (SRI JAY PRAKASH MISHRA, SMT SUNITA MISHRA)	W	2.91	1.20	01
A (SRI JAY PRAKASH MISHRA, SMT SUNITA MISHRA)	W	3.46	1.20	02

SCHEDULE OF DOOR:

BUILDING NAME	NAME	LENGTH	HEIGHT	NOS
A (SRI JAY PRAKASH MISHRA, SMT SUNITA MISHRA)	D	0.64	2.10	02
A (SRI JAY PRAKASH MISHRA, SMT SUNITA MISHRA)	D	0.76	2.10	10
A (SRI JAY PRAKASH MISHRA, SMT SUNITA MISHRA)	D	0.91	2.10	
A (SRI JAY PRAKASH MISHRA, SMT SUNITA MISHRA)	D	0.99	2.10	02
A (SRI JAY PRAKASH MISHRA, SMT SUNITA MISHRA)	D	1.07	2.10	02
A (SRI JAY PRAKASH MISHRA, SMT SUNITA MISHRA)	D	1.09	2.10	02
A (SRI JAY PRAKASH MISHRA, SMT SUNITA MISHRA)	D	1.22	2.10	01
A (SRI JAY PRAKASH MISHRA, SMT SUNITA MISHRA)	D	1.52	2.10	01

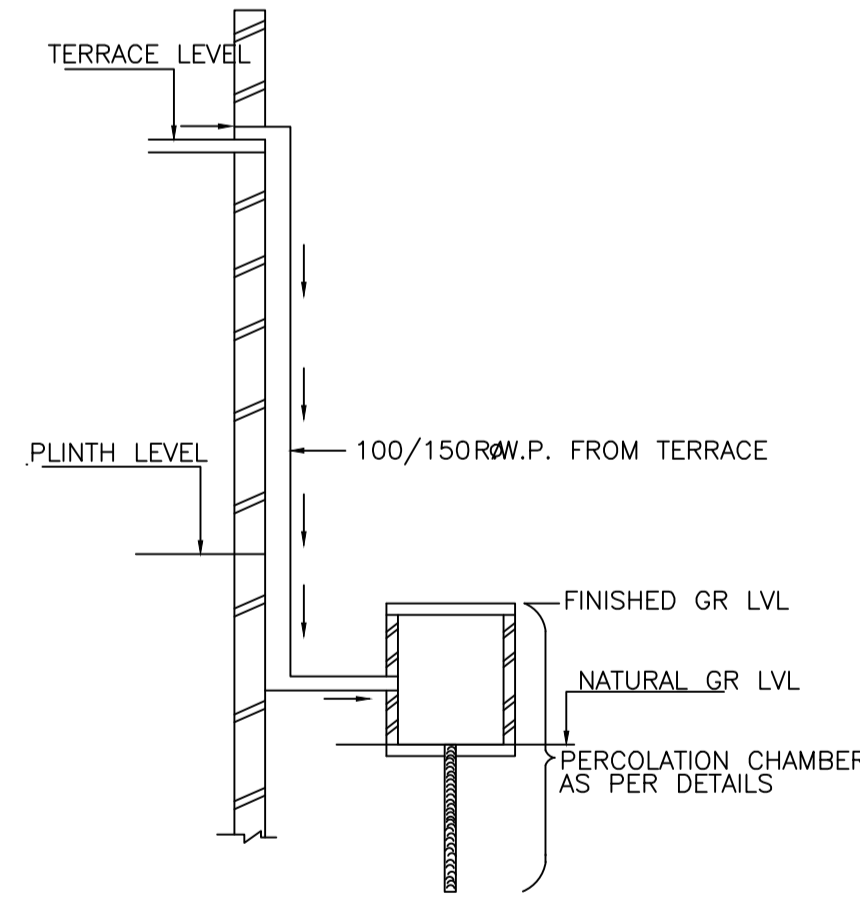
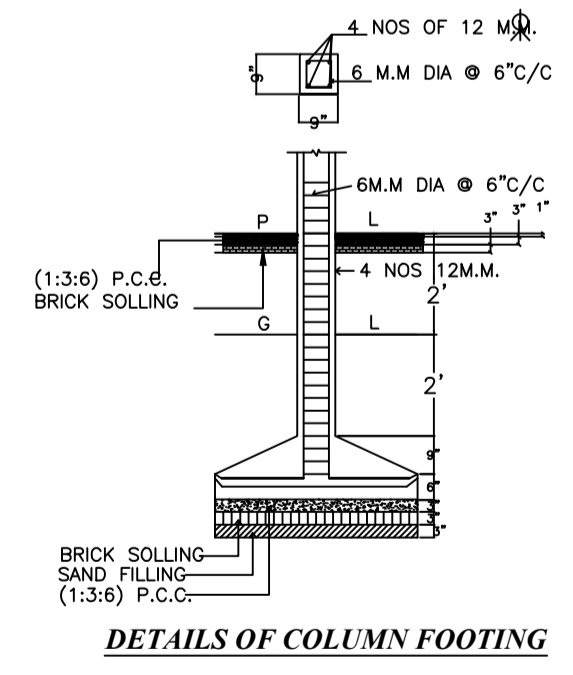
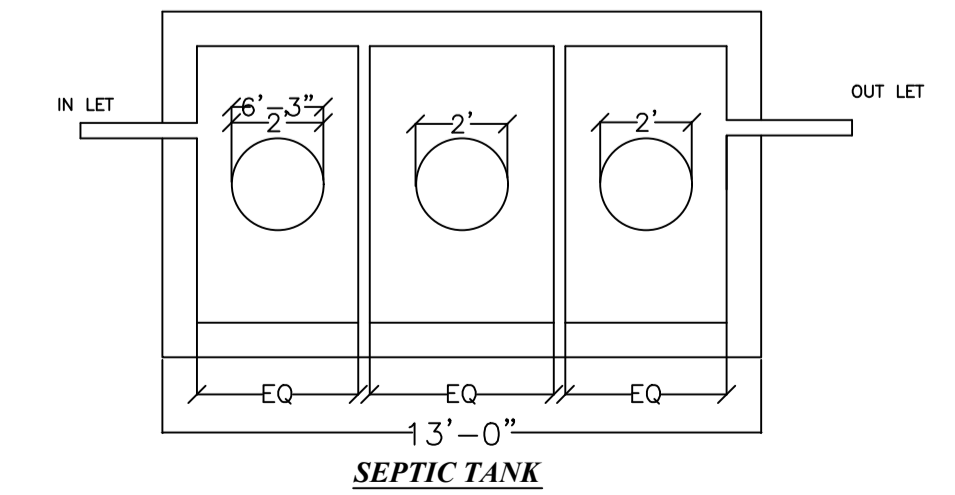
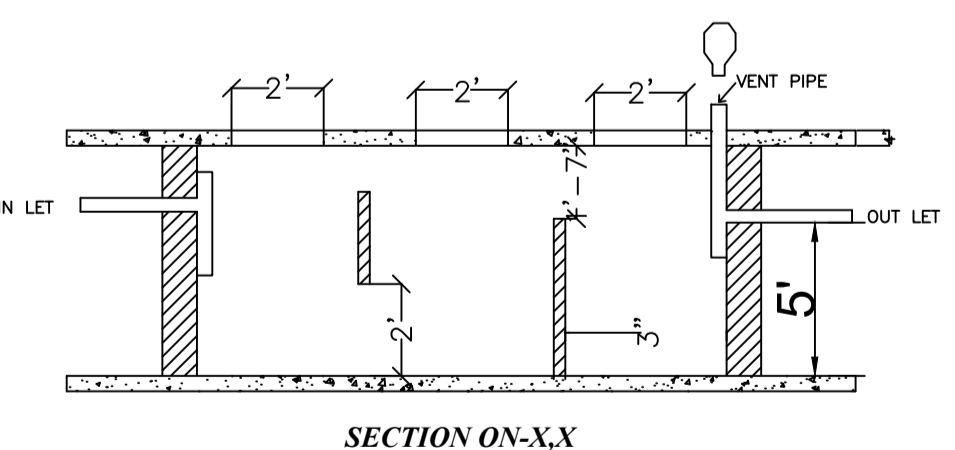
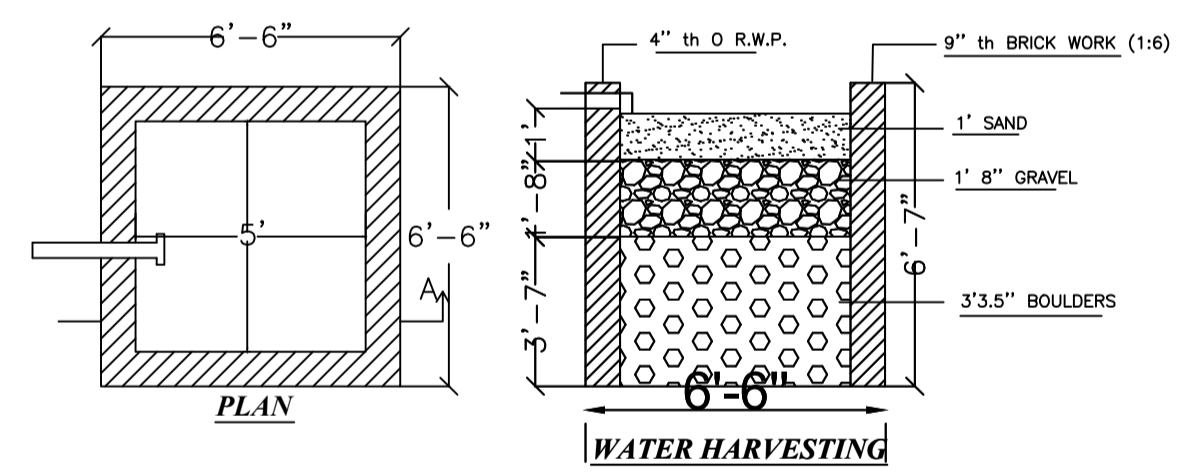

COLOR INDEX

PLOT BOUNDARY	Black
ABUTTING ROAD	Green
PROPOSED CONSTRUCTION	Red
COMMON PLOT	Yellow
ROAD WIDENING AREA	Blue
EXISTING (To be retained)	Orange
EXISTING (To be demolished)	Light Blue

Buildingwise Floor FAR Details

Floor Name	Building Name		Total	
	A (SRI JAY PRAKASH MISHRA, SMT SUNITA MISHRA)	Proposed FAR Area (Sq.mt.)	Total Proposed Built Up Area (Sq.mt.)	Total FAR Area (Sq.mt.)
Ground Floor	204.91	204.91	204.91	204.91
First Floor	204.91	204.91	204.91	204.91
Terrace Floor	0.00	0.00	0.00	0.00
Total	409.82	409.82	409.82	409.82

Building USE/SUBUSE Details

Building Name	Building Use	Building SubUse	Building Structure
A (SRI JAY PRAKASH MISHRA, SMT SUNITA MISHRA)	Residential	Residential Bldg/Apartment	Non-Highrise

FAR & Tenement Details (Table 4c-1)

Building	No. of Same Bldg	Total Built Up Area (Sq.mt.)	Proposed FAR Area (Sq.mt.) Resi.	Total FAR Area (Sq.mt.)	Total Consumed Additional FAR Area (Sq.mt.)	Tnmt (No.)
A (SRI JAY PRAKASH MISHRA, SMT SUNITA MISHRA)	1	409.82	409.82	409.82	409.82	01
Grand Total	1	409.82	409.82	409.82	409.82	01

LTP NAME AND SIGNATURE	STRUCTURAL ENG'S NAME AND SIGNATURE	BUILDER NAME AND SIGNATURE	DIGITAL SIGNATURE
RAJEEV RANJAN SINGH MADA/ENG/0004/2019			

Proposal Basic Information	
Proposal File No.	MADA/BP/0003/2019
Owner Name	SRI JAY PRAKASH MISHRA, SMT SUNITA MISHRA
Khata No	OLD-01,11, NEW-17,55
Plot No	OLD-126,132, NEW-52,54
Village Name	Narayanpur
Use	Residential
SubUse	Bungalow/ Dwelling / Non Apartment



FRONT ELEVATION

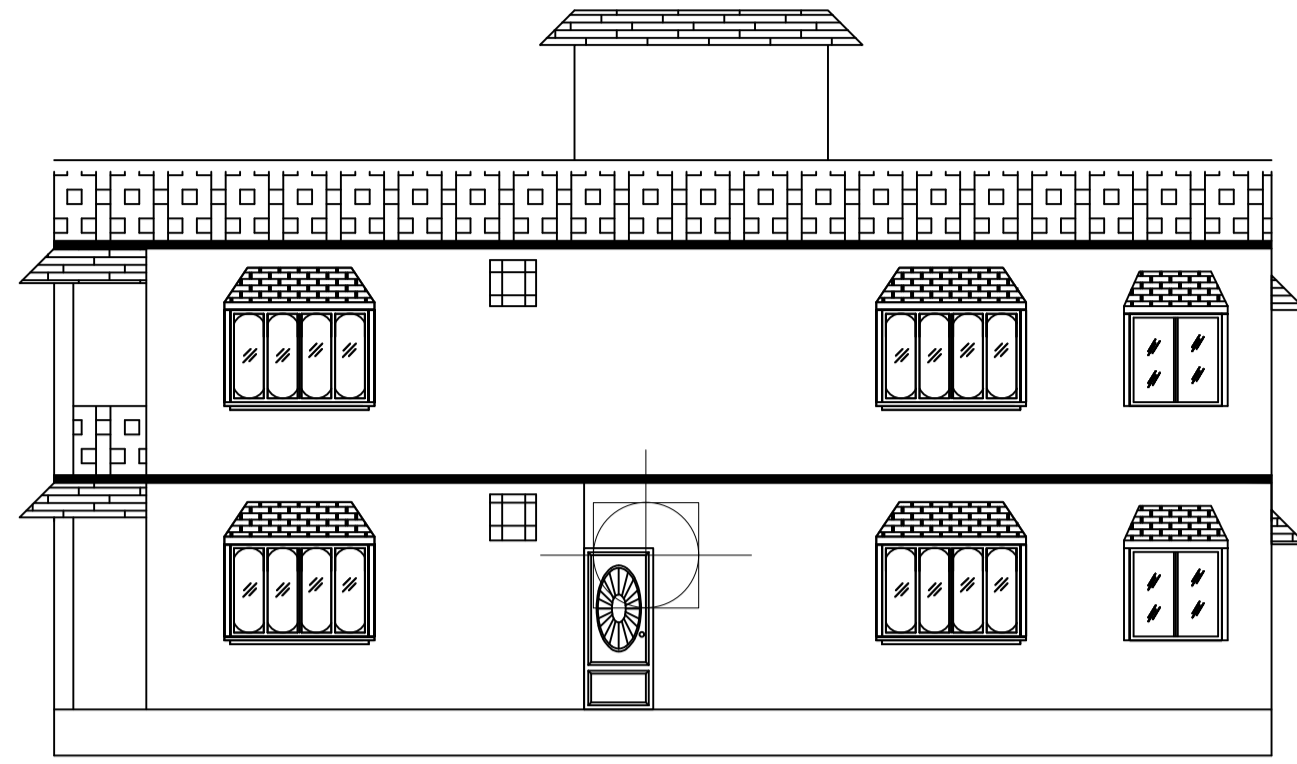

RIGHT SIDE ELEVATION

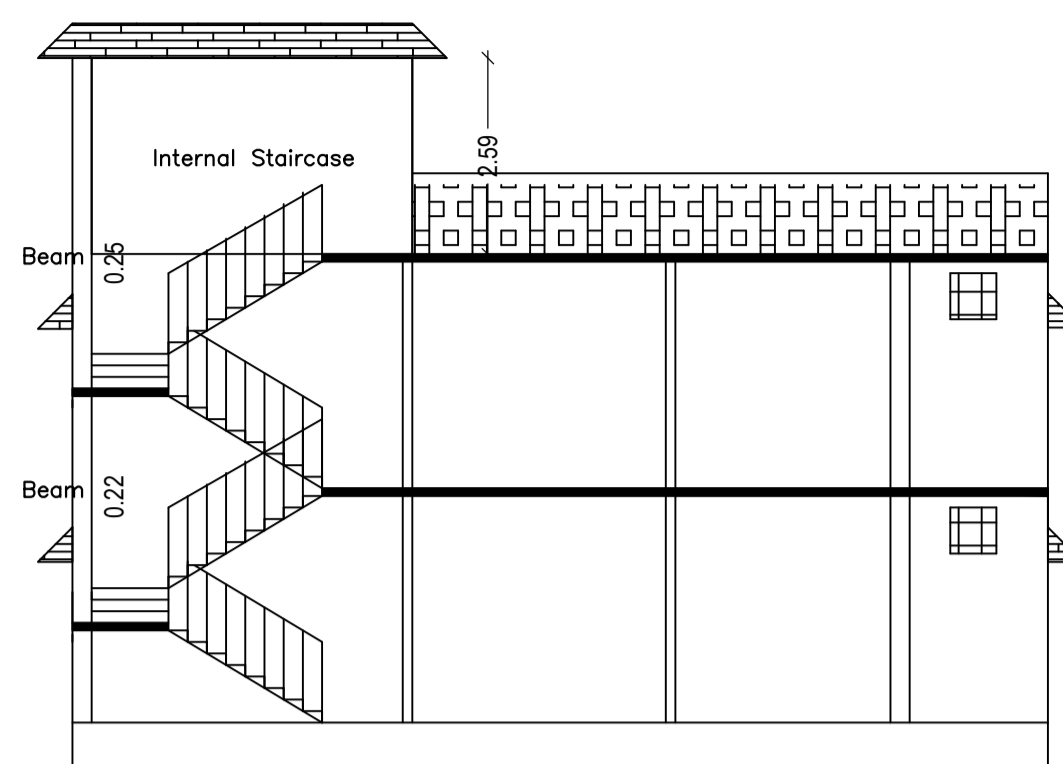

SECTION ON XX

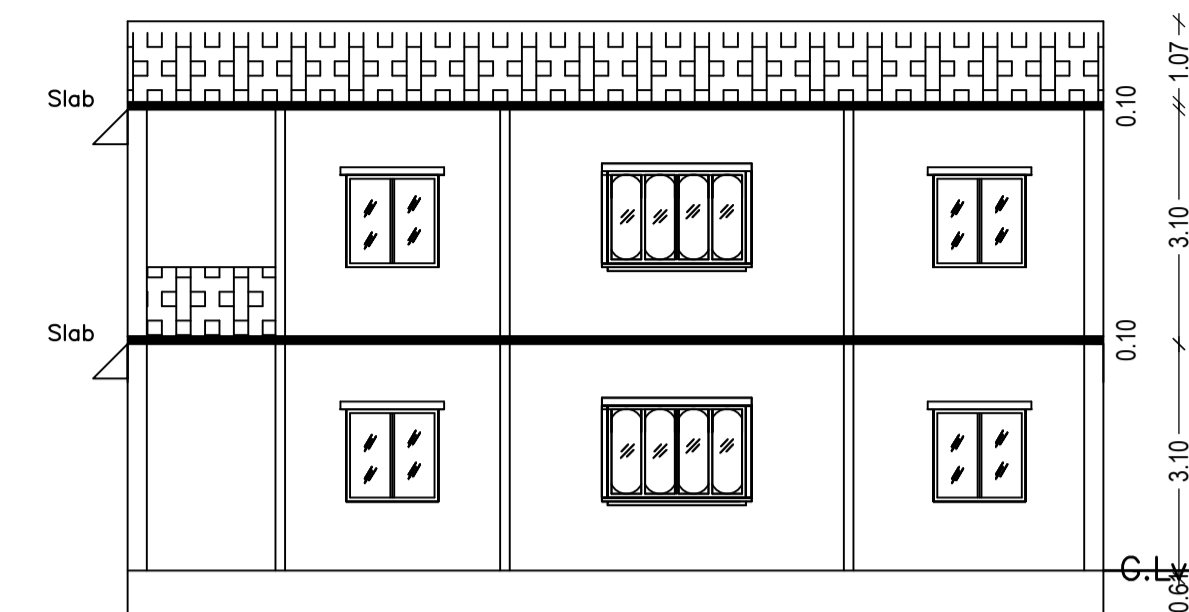

SECTION ON YY

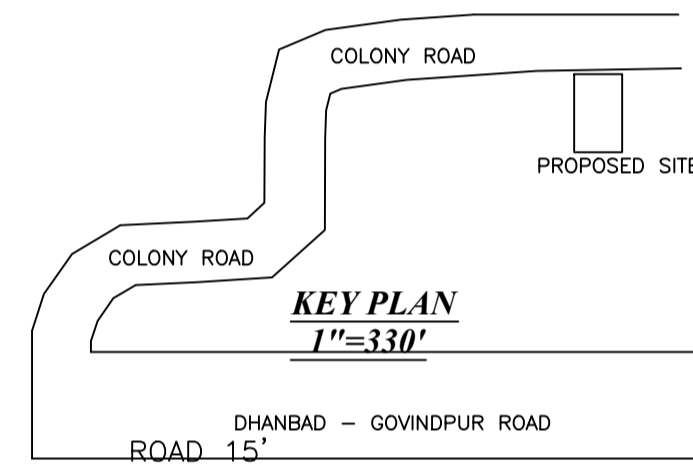

Key Plan

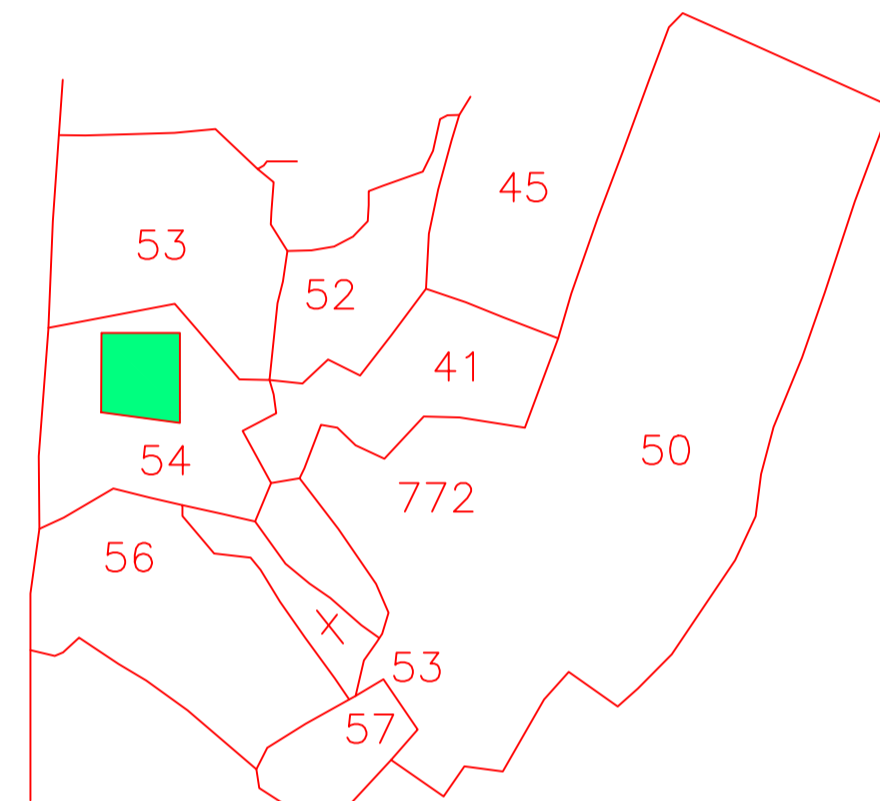

Location Plan

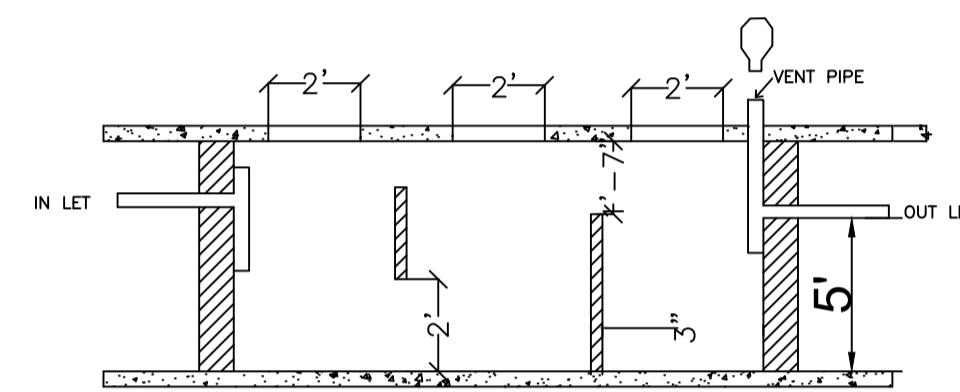

SECTION ON-X-X

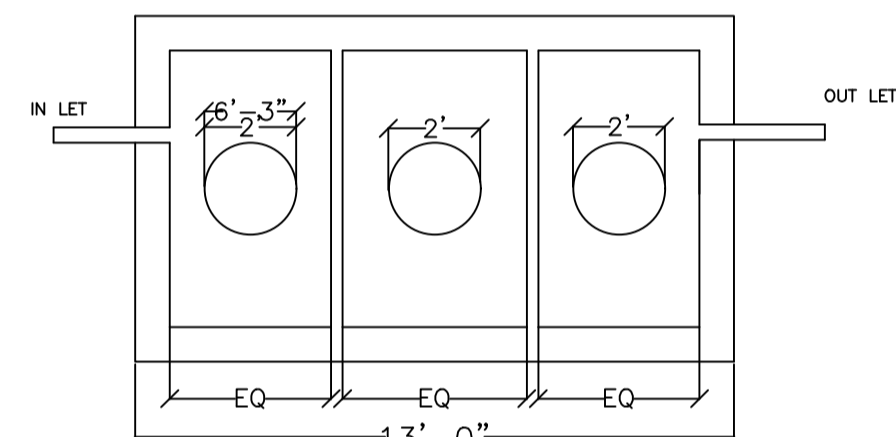

SEPTIC TANK

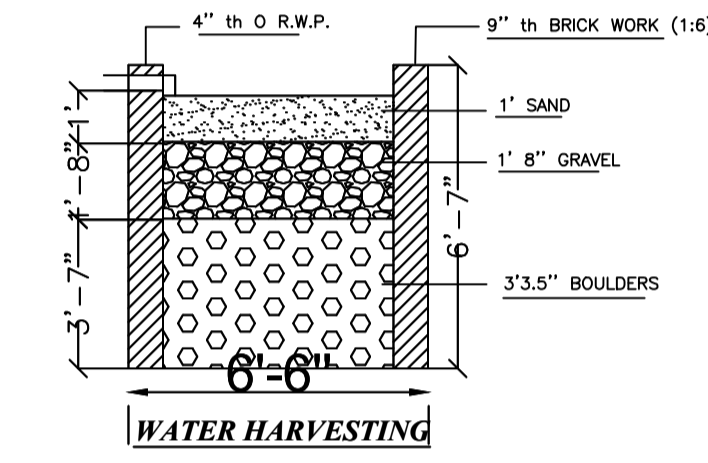

WATER HARVESTING

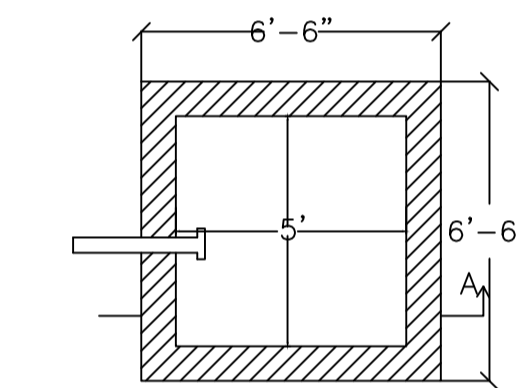

PLAN

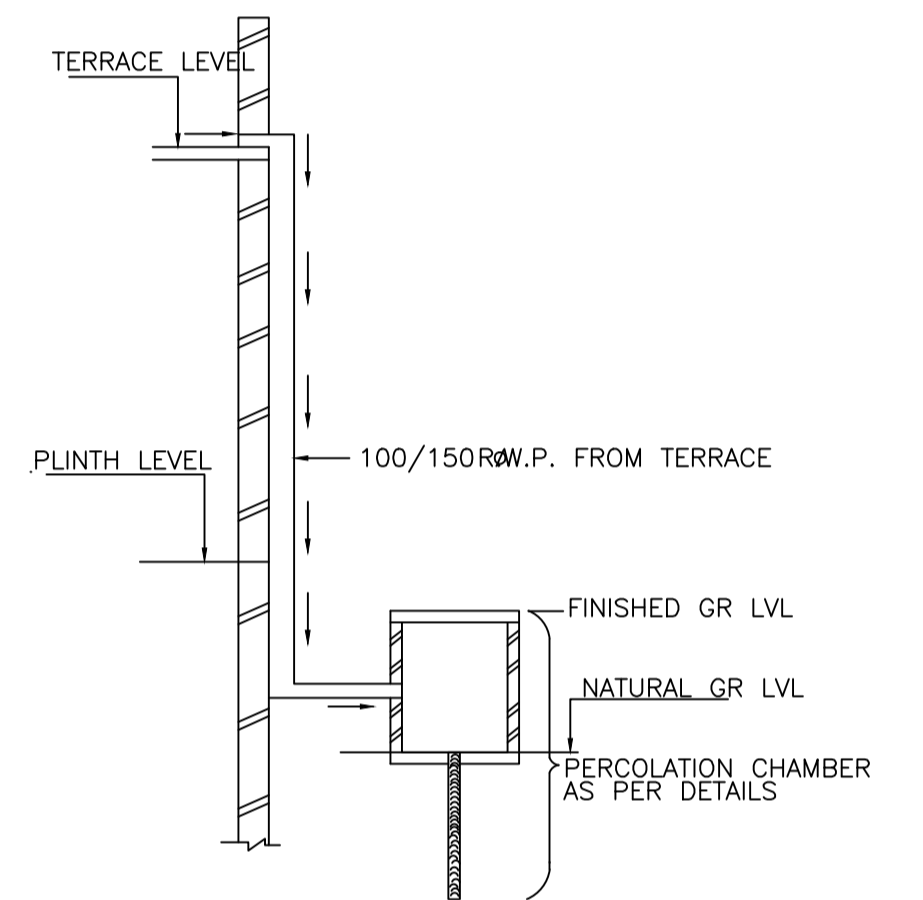

ROOF TOP RAIN WATER COLLECTION SYSTEM

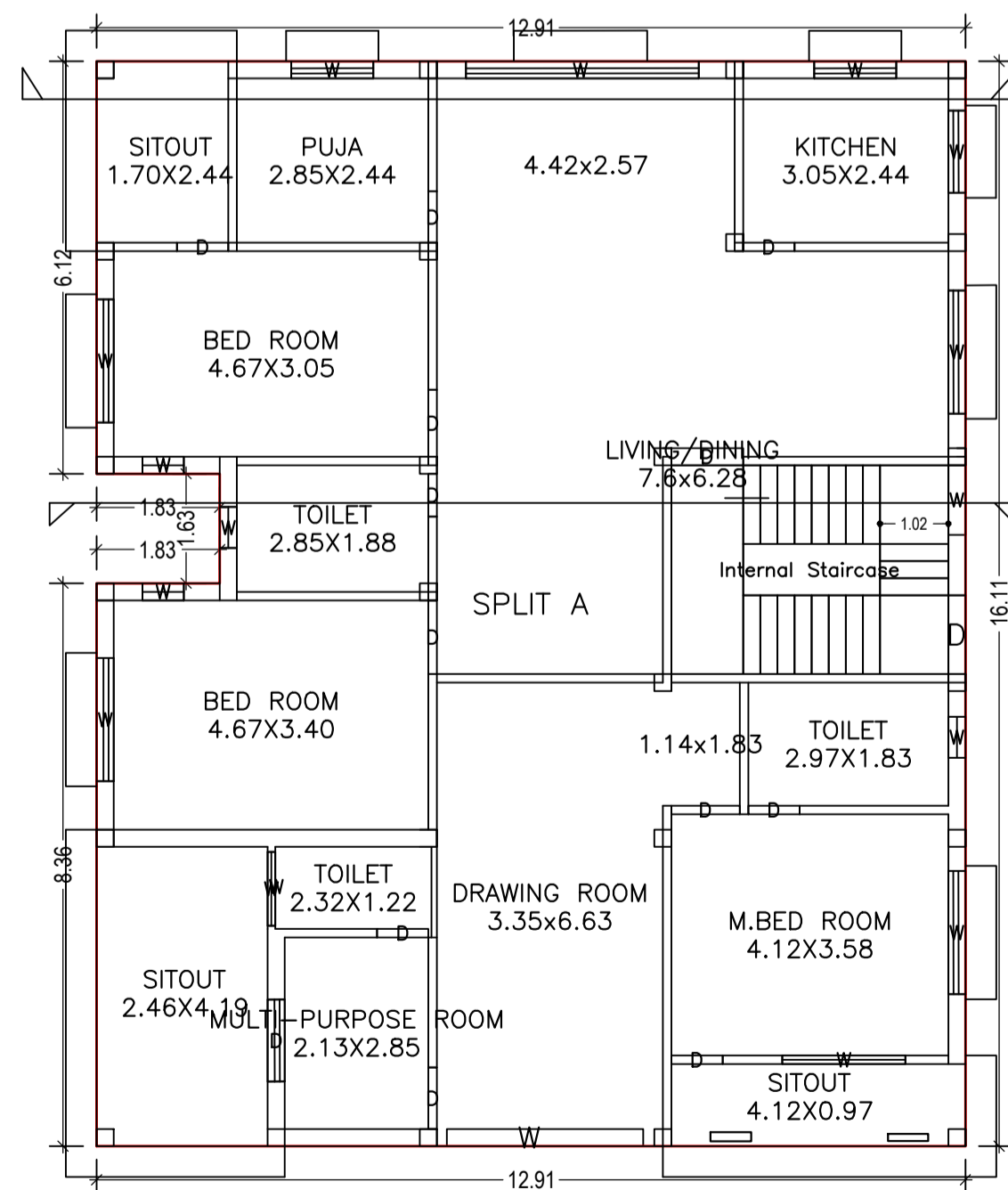

GROUND FLOOR PLAN
(Proposed)
(SCALE 1:100)

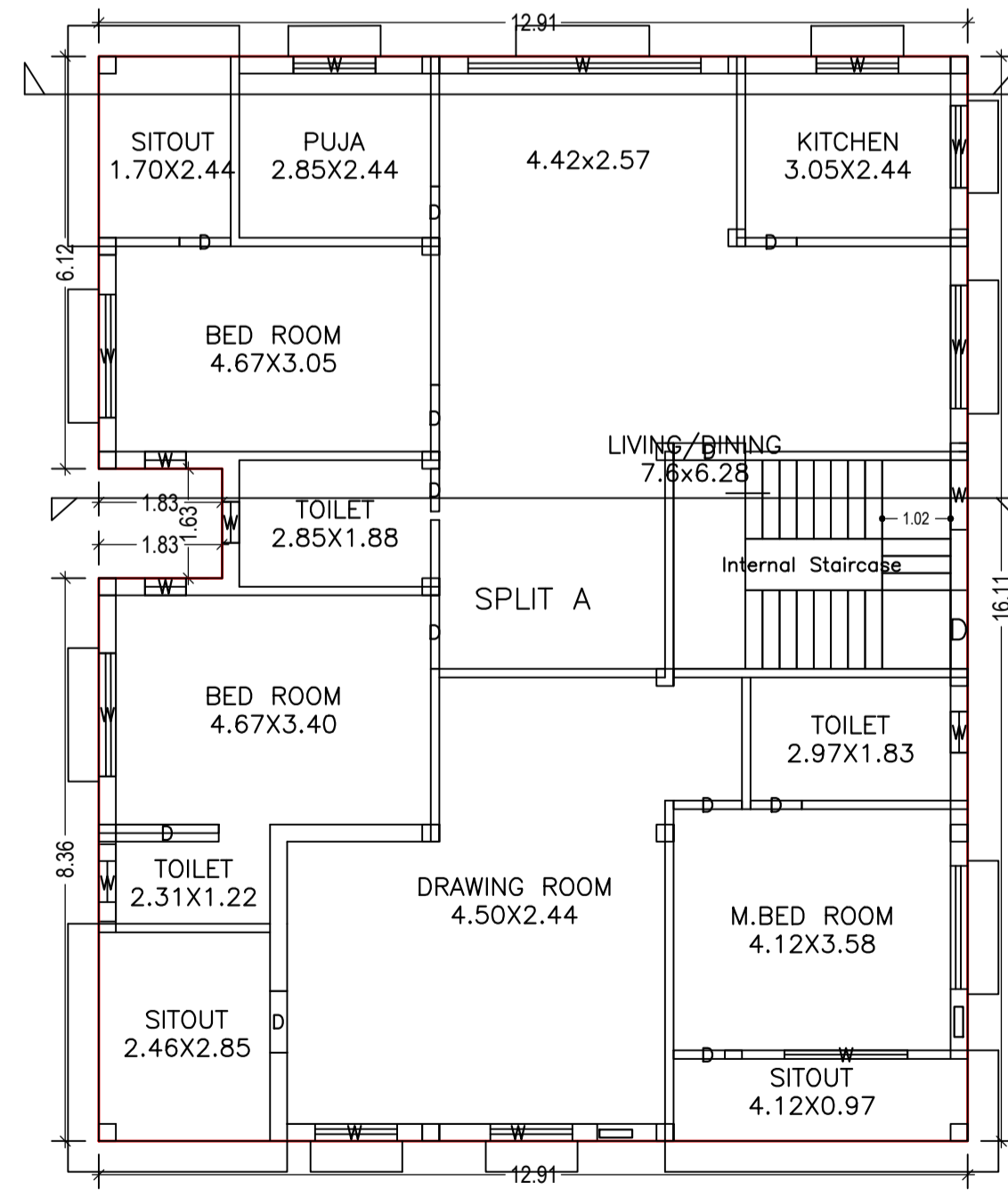

FIRST FLOOR PLAN
(Proposed)
(SCALE 1:100)

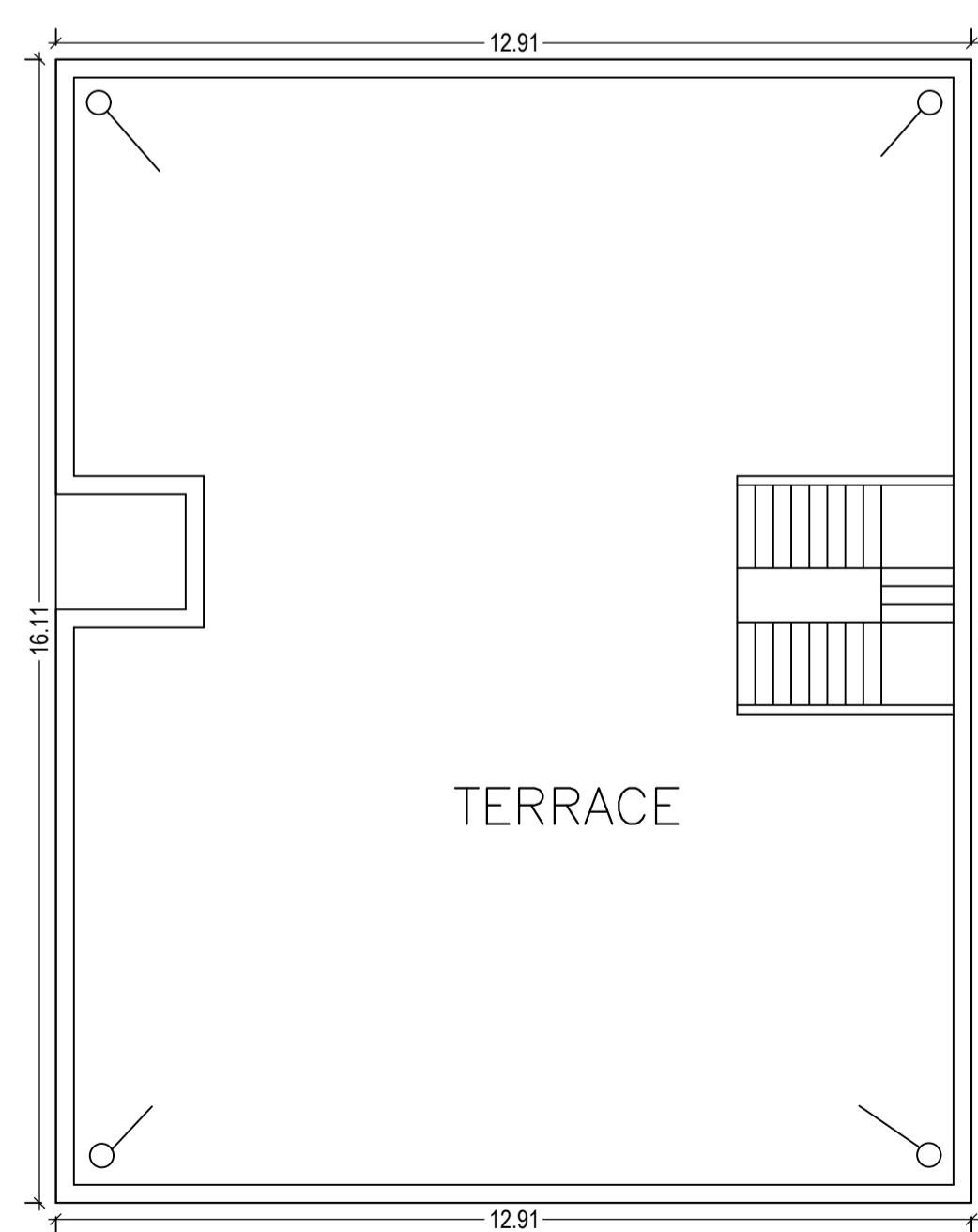

TERRACE FLOOR PLAN
(SCALE 1:100)

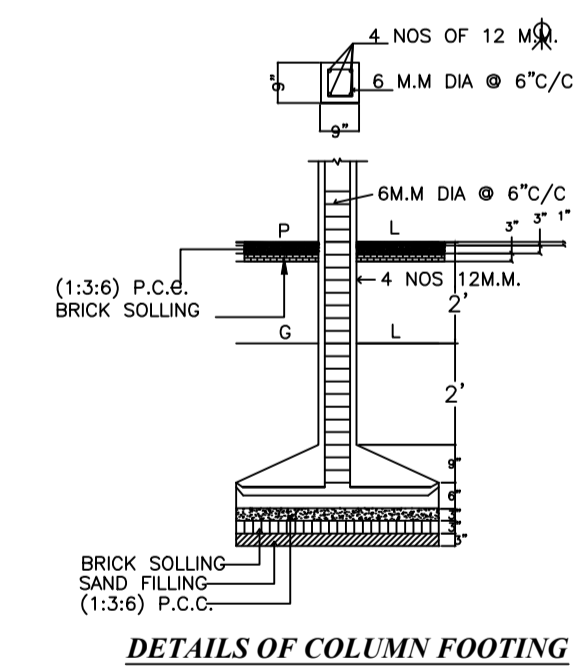

DETAILS OF COLUMN FOOTING

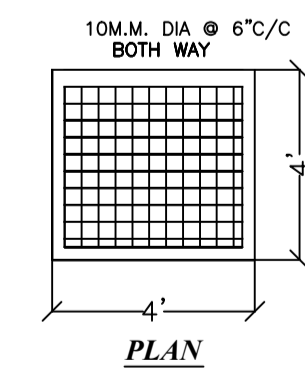

PLAN

LTP NAME AND SIGNATURE	STRUCTURAL ENG'S NAME AND SIGNATURE	BUILDER NAME AND SIGNATURE	DIGITAL SIGNATURE
RAJEEV RANJAN SINGH MADA/ENG/0004/2019			