

SECTIONAL AT Y-Y

SECTIONAL AT X-X

LOCATION

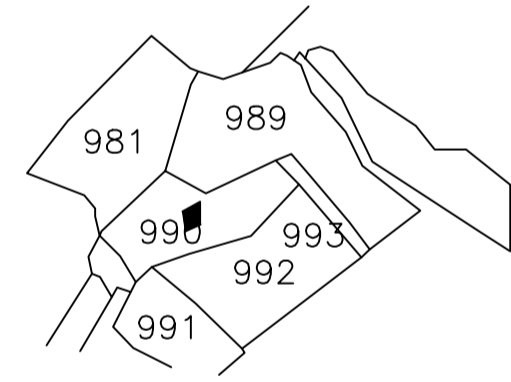

KEY PLAN

SCHEDULE OF DOOR:

| BUILDING NAME | NAME | LENGTH | HEIGHT | NOS |
|---------------|------|--------|--------|-----|
| AA (A)        | d    | 0.90   | 2.10   | 09  |

SCHEDULE OF WINDOW/VENTILATION:

| BUILDING NAME | NAME | LENGTH | HEIGHT | NOS |
|---------------|------|--------|--------|-----|
| AA (A)        | w    | 1.30   | 1.20   | 01  |
| AA (A)        | w    | 1.80   | 1.20   | 14  |

Building :AA (A)

| Floor Name                       | Total Built Up Area (Sq.mt.) | Proposed FAR Area (Sq.mt.) | Total FAR Area (Sq.mt.) | Total Consumed Additional FAR Area (Sq.mt.) | Tnmt (No.) |
|----------------------------------|------------------------------|----------------------------|-------------------------|---|------------|
| Ground Floor                     | 67.22                        | 67.22                      | 67.22                   | 67.22                                       | 01         |
| First Floor                      | 67.22                        | 67.22                      | 67.22                   | 67.22                                       | 00         |
| Terrace Floor                    | 0.00                         | 0.00                       | 0.00                    | 0.00  | 00         |
| Total :                          | 134.44                       | 134.44                     | 134.44                  | 134.44                                      | 01         |
| Total Number of Same Buildings : | 1                            |                            |                         |   |            |
| Total :                          | 134.44                       | 134.44                     | 134.44                  | 134.44                                      | 01         |

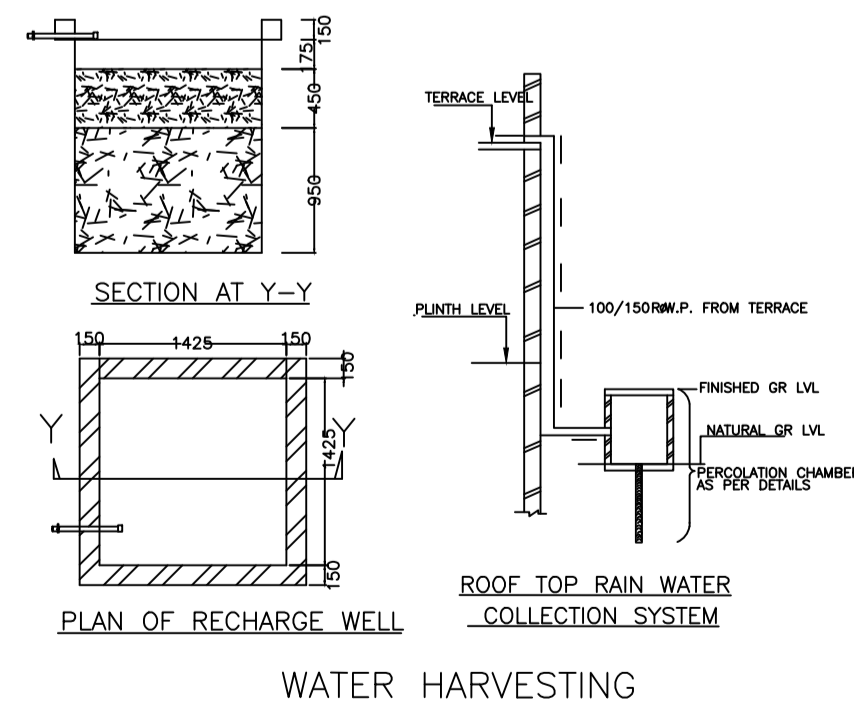

WATER HARVESTING

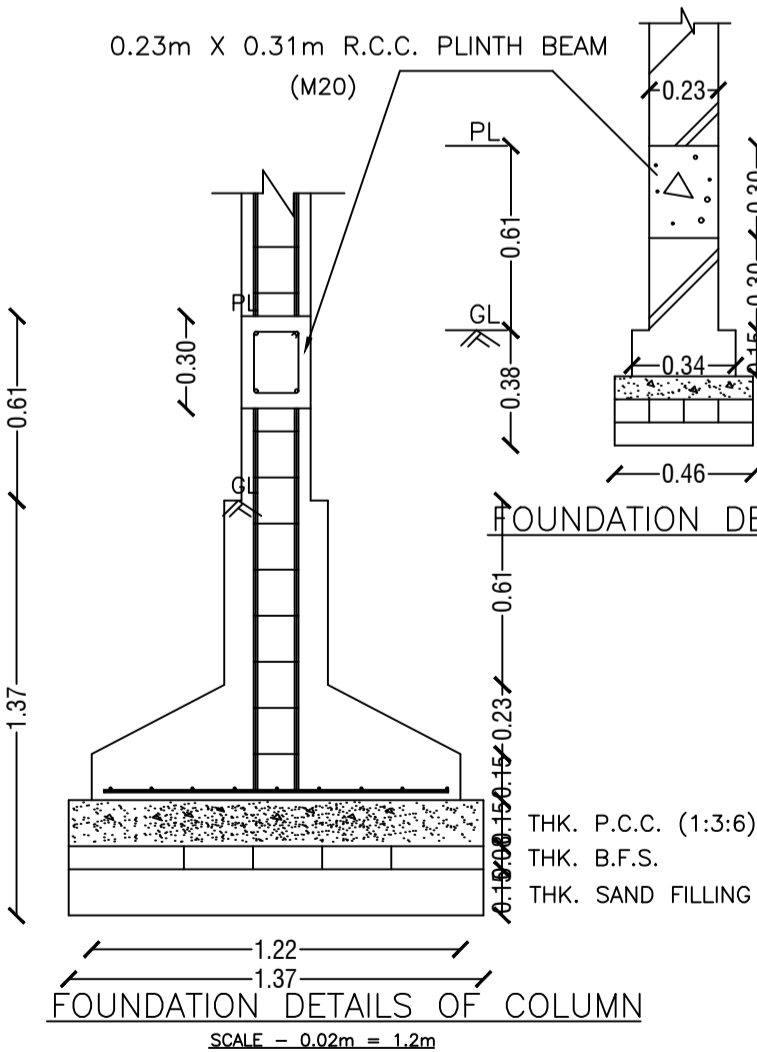

FOUNDATION DETAILS OF COLUMN

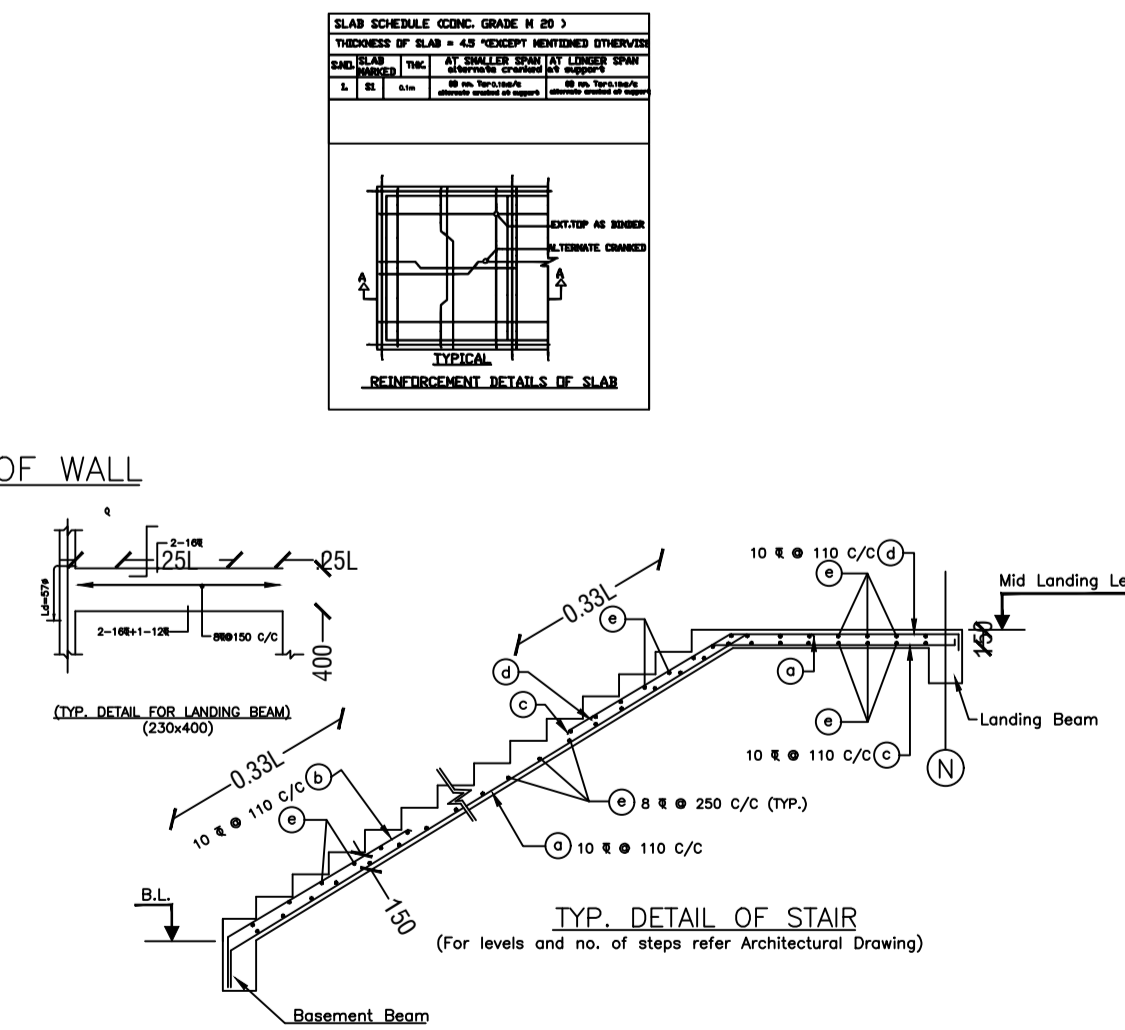

TYP. DETAIL OF STAIR

Proposal Basic Information

|                   |                                    |
|-------------------|------------------------------------|
| Proposal File No. | MADA/BP/0064/2020                  |
| Owner Name        | RIMA SINGH                         |
| Khata No          | OLD - 56 , NEW - 237               |
| Plot No           | OLD - 770 , NEW - 990              |
| Village Name      | Nawadh                             |
| Use               | Residential                        |
| SubUse            | Bungalow/ Dwelling / Non Apartment |

|  |   |            |
|--|---|------------|
| AREA STATEMENT MINERAL AREA DEVELOPMENT AUTHORITY                  | VERSION NO.: 1.0.46                             | SQ.MT.     |
| PROJECT DETAIL:  | VERSION DATE: 22/06/2020                        |            |
| Region: JHARKHAND URBAN LOCAL BODIES                               | Plot Use: Residential                           |            |
| District: DHANBAD  | Plot SubUse: Bungalow/ Dwelling / Non Apartment |            |
| Authority: MINERAL AREA DEVELOPMENT AUTHORITY                      | PlotNearby/ReligiousStructure: NA               |            |
| Inward No: MADA/BP/0064/2020                                       | Plot/SubPlot No: OLD - 770 , NEW - 990          |            |
| Application Type: General Proposal                                 | North: Plot No. - LOT NO. 11                    |            |
| Project Type: Building Permission                                  | South: Plot No. - LOT NO. 13                    |            |
| Nature of Development: New   | East: Plot No. - LOT NO. 10 & 14                |            |
| Location of Development Area: Old Area                             | West: Road Width - 6                            |            |
| AREA OF PLOT (Minimum)   | (A)   | 131.17     |
| NET AREA OF PLOT(Gross Plot Area - Deduction from Gross Plot area) | (A-Deductions)                                  | 131.17     |
| Deduction for Balance Plot Area(from Gross Plot Area)              |   |            |
| Common Plot  |   | 25.48      |
| Total  |   | 25.48      |
| BALANCE AREA OF PLOT (Net Plot Area - Recreational/Amenity spaces) | (A-Deductions)                                  | 105.69     |
| PLOT AREA FOR COVERAGE(Net Plot Area)                              | (A-Deductions)                                  | 131.17     |
| Plot Area for FAR (Net Plot Area + Road/Widening Area)             | (A-Deductions)                                  | 131.17     |
| COVERAGE CHECK   |   |            |
| Permissible Coverage area ( 70.00 % )                              |   | 91.82      |
| Proposed Coverage Area ( 51.25 % )                                 |   | 67.22      |
| Total Prop. Coverage Area ( 51.25 % )                              |   | 67.22      |
| Balance coverage area ( 18.75 % )                                  |   | 24.60      |
| FAR CHECK  |   |            |
| Perm. FAR Area ( 1.50 )  |   | 196.76     |
| Total Perm. FAR area   |   | 196.76     |
| Residential FAR  |   | 134.44     |
| Proposed FAR Area  |   | 134.44     |
| Total Proposed FAR Area  |   | 134.44     |
| Consumed FAR (Factor)  |   | 1.02       |
| Balance FAR Area   |   | 62.32      |
| BUILT UP AREA CHECK  |   |            |
| Total Proposed BuiltUp Area  |   | 134.44     |
| ARCHITECT (Regd)   | MANOJ KUMAR SINGH                               |            |
| ENGINEER (Regd)  |   |            |
| SUPERVISOR (Regd)  |   |            |
| OWNER (Regd)   | RIMA SINGH                                      |            |
| DEVELOPMENT AUTHORITY  |   | LOCAL BODY |

COLOR INDEX

|                             |            |
|-----------------------------|------------|
| PLOT BOUNDARY               | Black      |
| ABUTTING ROAD               | Green      |
| PROPOSED CONSTRUCTION       | Red        |
| COMMON PLOT                 | Yellow     |
| ROAD WIDENING AREA          | Blue       |
| EXISTING (To be retained)   | Light Blue |
| EXISTING (To be demolished) | Orange     |

Buildingwise Floor FAR Details

| Floor Name    | Building Name AA (A)            |                            | Total                                 |                         |
|---------------|---------------------------------|----------------------------|---------------------------------------|-------------------------|
|               | Proposed Built Up Area (Sq.mt.) | Proposed FAR Area (Sq.mt.) | Total Proposed Built Up Area (Sq.mt.) | Total FAR Area (Sq.mt.) |
| Ground Floor  | 67.22                           | 67.22                      | 67.22                                 | 67.22                   |
| First Floor   | 67.22                           | 67.22                      | 67.22                                 | 67.22                   |
| Terrace Floor | 0.00                            | 0.00                       | 0.00                                  | 0.00                    |
| Total :       | 134.44                          | 134.44                     | 134.44                                | 134.44                  |

Building USE/SUBUSE Details

| Building Name | Building Use | Building SubUse            | Building Structure |
|---------------|--------------|----------------------------|--------------------|
| AA (A)        | Residential  | Residential Bldg/Apartment | Non-Highrise       |

FAR & Tenement Details (Table 4c-1)

| Building      | No. of Same Bldg | Total Built Up Area (Sq.mt.) | Proposed FAR Area (Sq.mt.) | Total FAR Area (Sq.mt.) | Total Consumed Additional FAR Area (Sq.mt.) | Tnmt (No.) |
|---------------|------------------|------------------------------|----------------------------|-------------------------|---|------------|
| AA (A)        | 1                | 134.44                       | 134.44                     | 134.44                  | 134.44                                      | 01         |
| Grand Total : | 1                | 134.44                       | 134.44                     | 134.44                  | 134.44                                      | 01         |

UnitBUA Table for Building :AA (A)

| FLOOR             | Name    | UnitBUA Type | UnitBUA Area | Carpet Area | No. of Rooms | No. of Tenement |
|-------------------|---------|--------------|--------------|-------------|--------------|-----------------|
| GROUND FLOOR PLAN | SPLIT 1 | FLAT         | 134.44       | 134.41      | 5            | 1               |
| FIRST FLOOR PLAN  | SPLIT 1 | FLAT         | 0.00         | 0.00        | 6            | 0               |
| Total:            | -       | -            | 134.44       | 134.41      | 11           | 1               |

| LTP NAME AND SIGNATURE                   | STRUCTURAL ENG'S NAME AND SIGNATURE | BUILDER NAME AND SIGNATURE | DIGITAL SIGNATURE |
|--|-------------------------------------|----------------------------|-------------------|
| MANOJ KUMAR SINGH<br>MADA/FTMN/0023/2019 |                                     |                            |                   |

| Proposal Basic Information |                                    |
|----------------------------|------------------------------------|
| Proposal File No.          | MADA/BP/0064/2020                  |
| Owner Name                 | RIMA SINGH                         |
| Khata No                   | OLD - 56 , NEW - 237               |
| Plot No                    | OLD - 770 , NEW - 990              |
| Village Name               | Nawadhi                            |
| Use                        | Residential                        |
| SubUse                     | Bungalow/ Dwelling / Non Apartment |

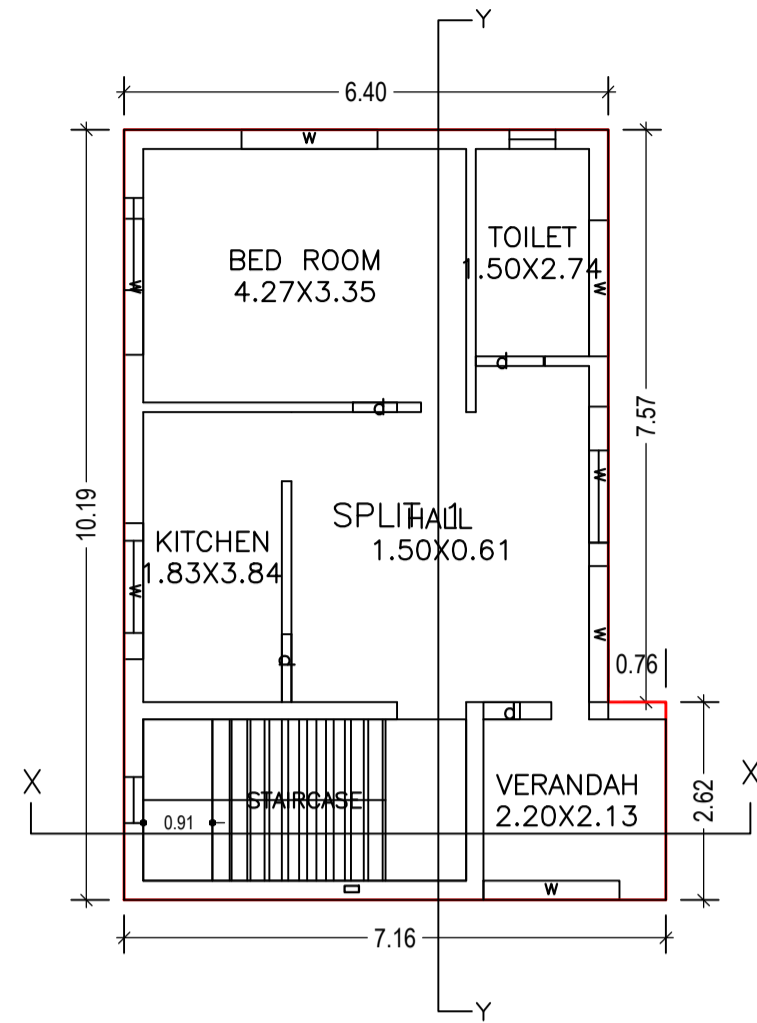

GROUND FLOOR PLAN (Proposed) (SCALE 1:100)

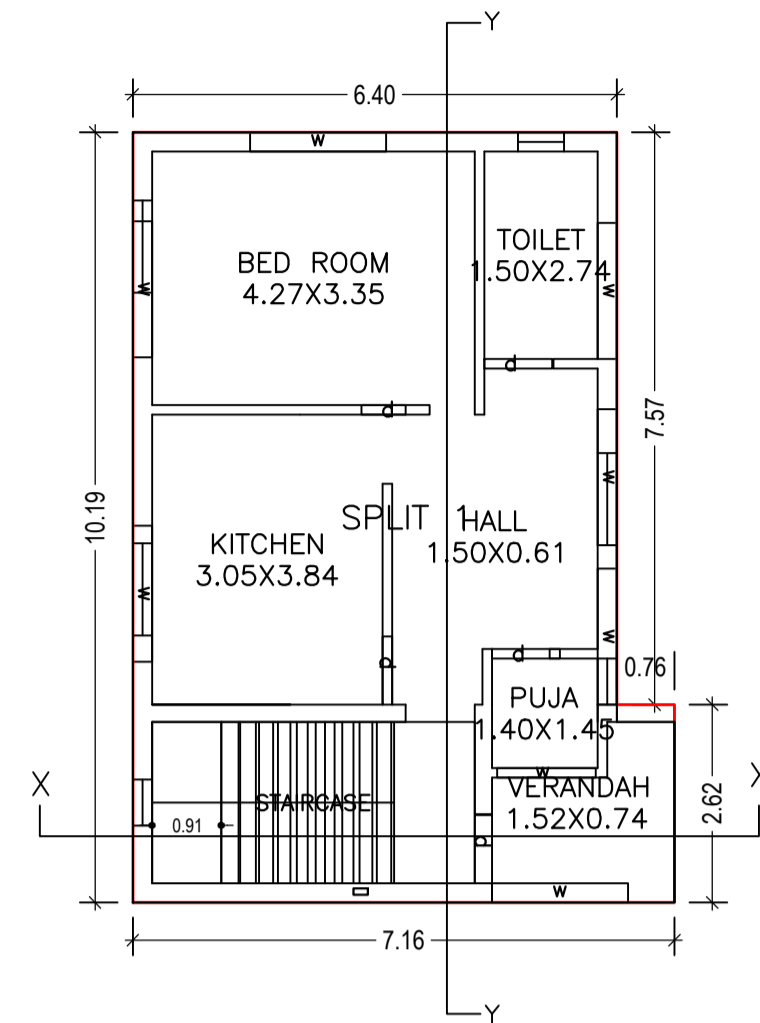

FIRST FLOOR PLAN (Proposed) (SCALE 1:100)

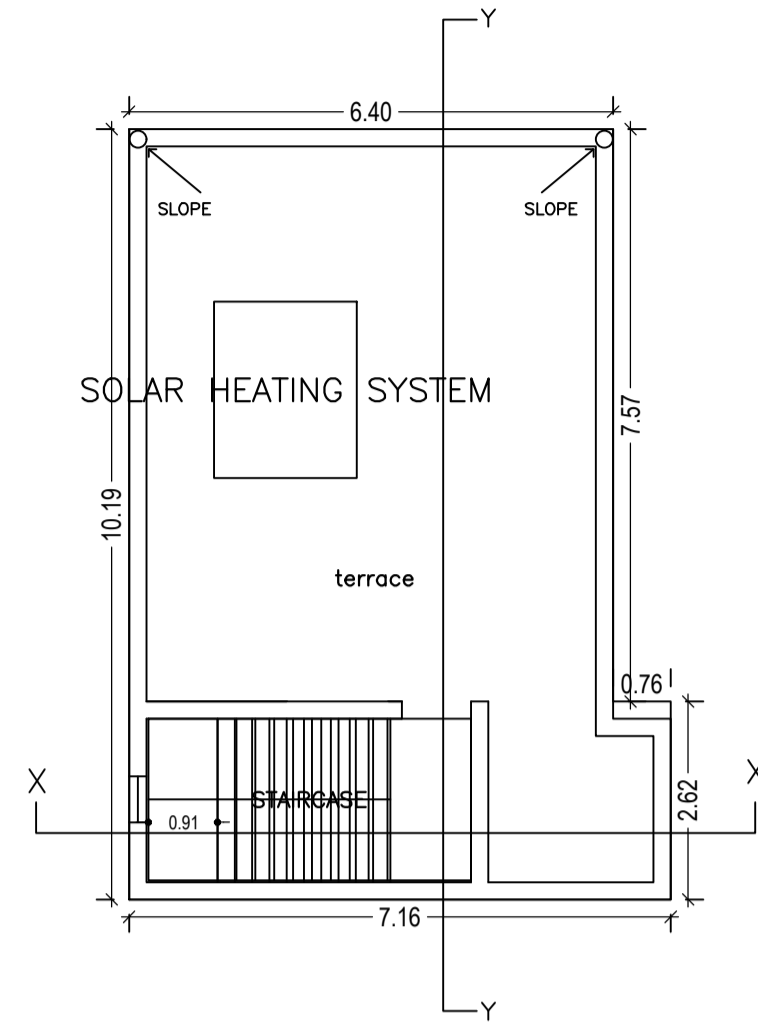

TERRACE FLOOR PLAN (SCALE 1:100)

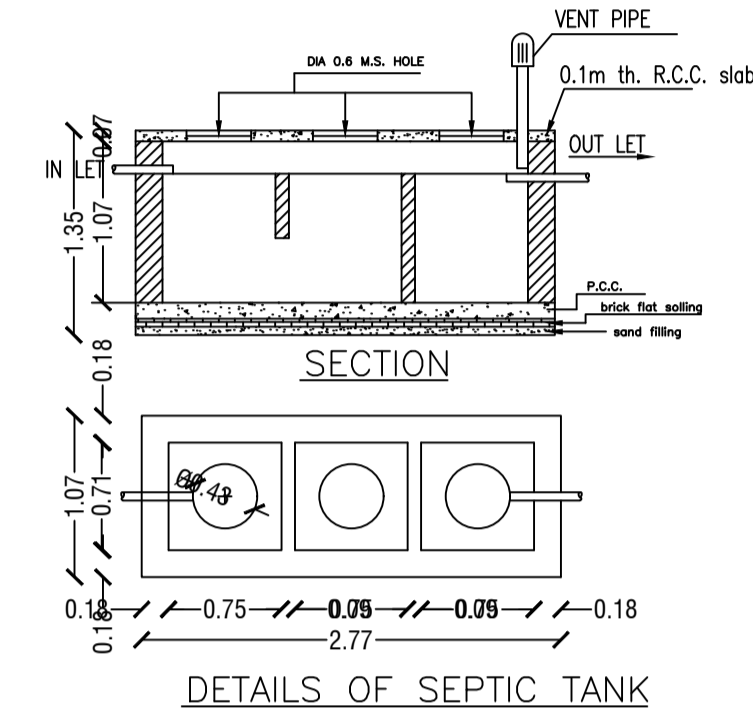

DETAILS OF SEPTIC TANK

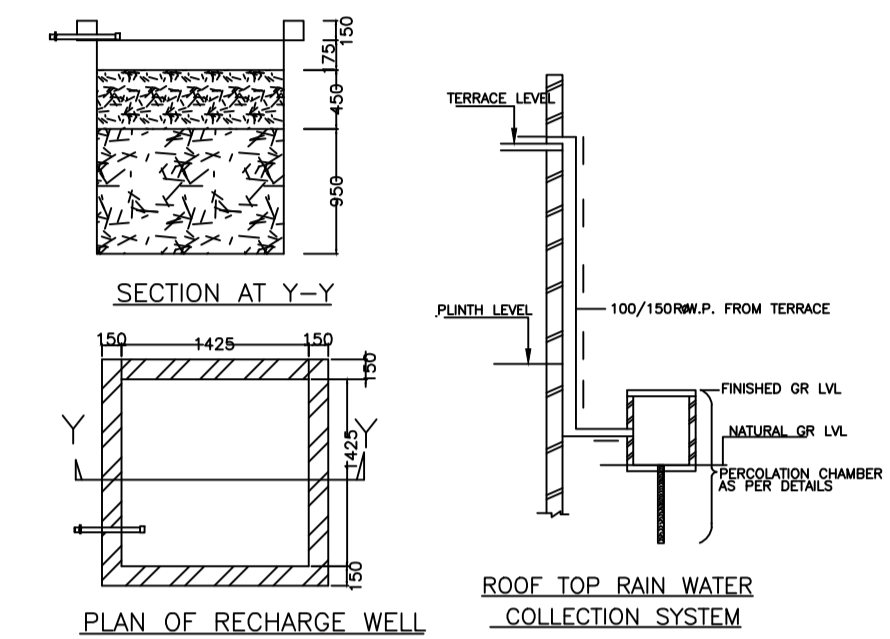

WATER HARVESTING

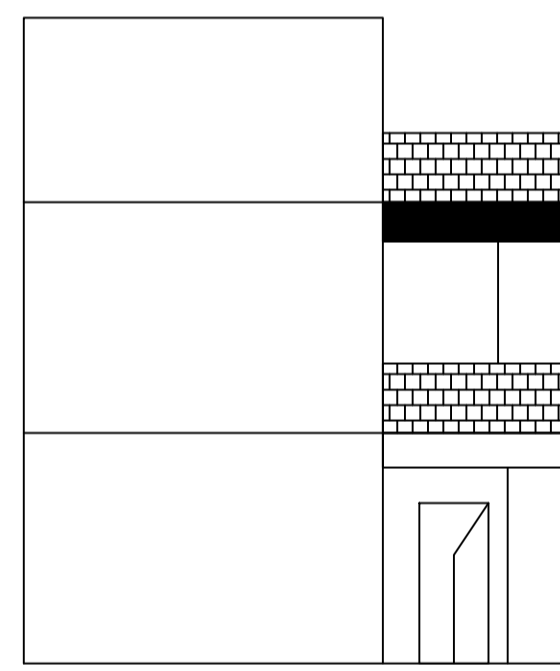

FRONT ELEVATION

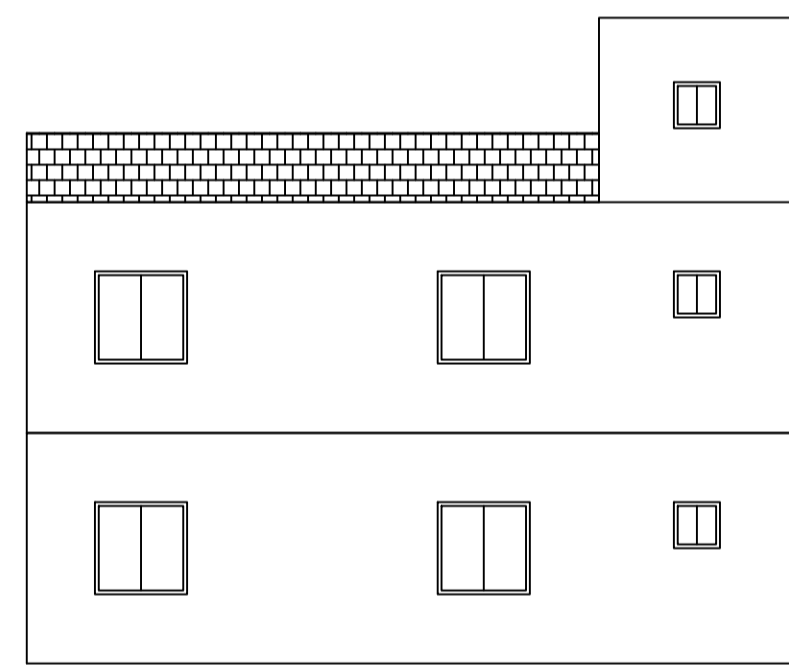

LEFT SIDE ELEVATION

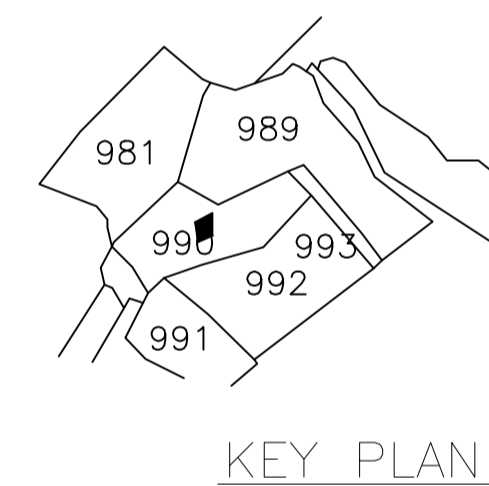

KEY PLAN

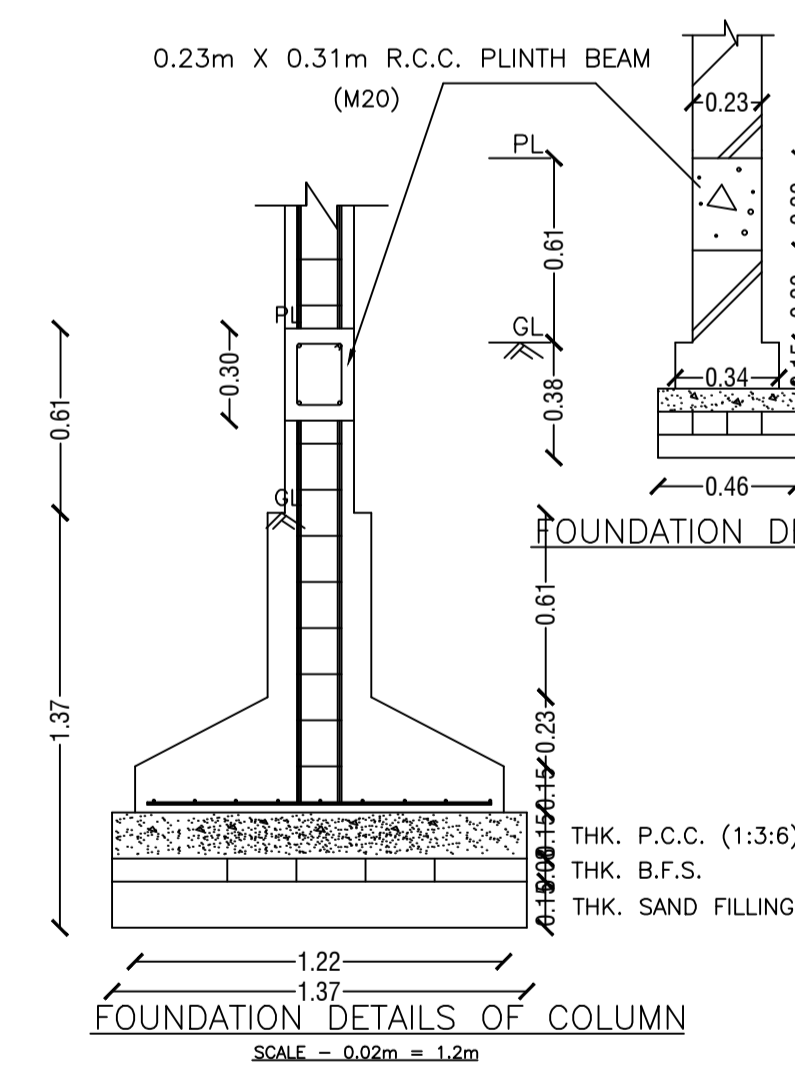

FOUNDATION DETAILS OF COLUMN  
SCALE - 0.02m = 1.2m

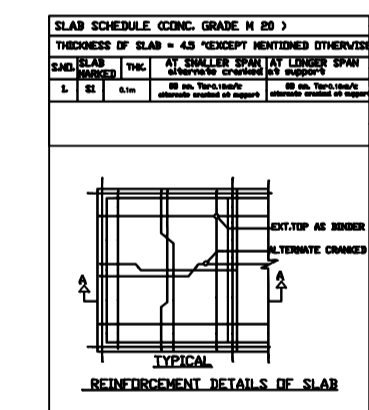

TYPICAL REINFORCEMENT DETAILS OF SLAB

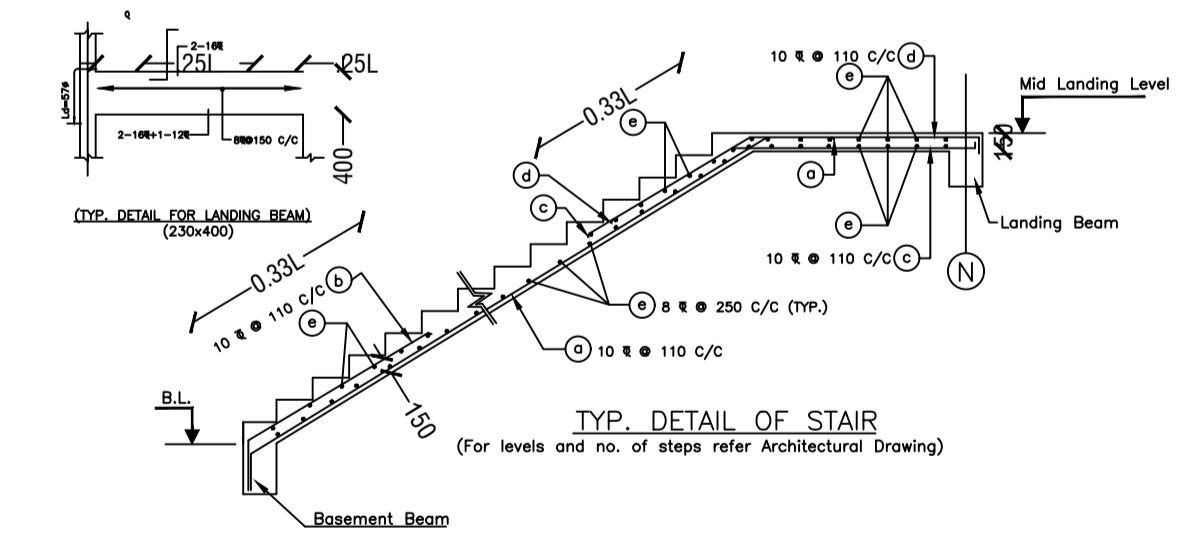

TYP. DETAIL OF STAIR  
(For levels and no. of steps refer Architectural Drawing)

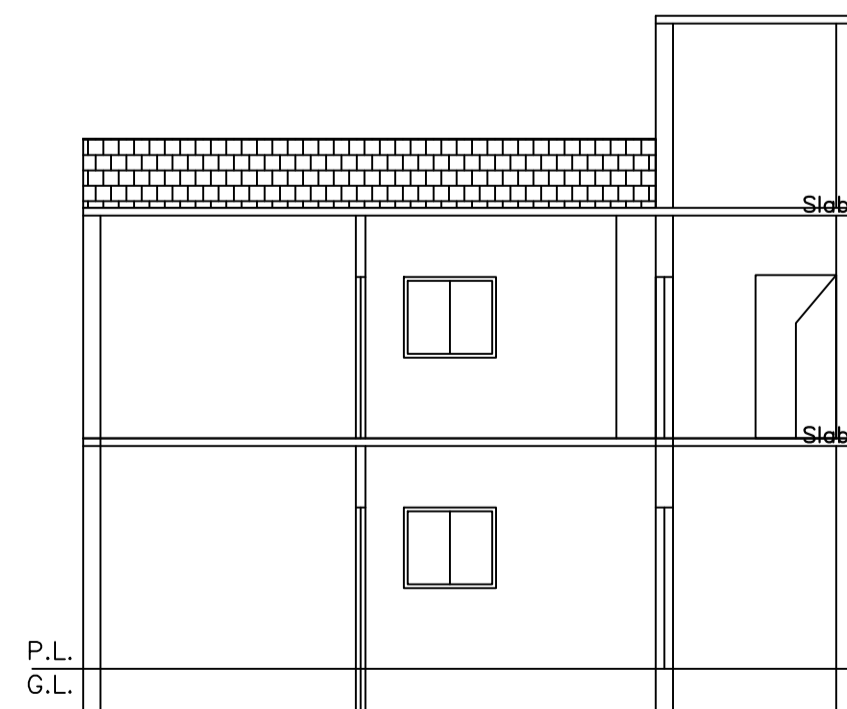

SECTIONAL AT Y-Y

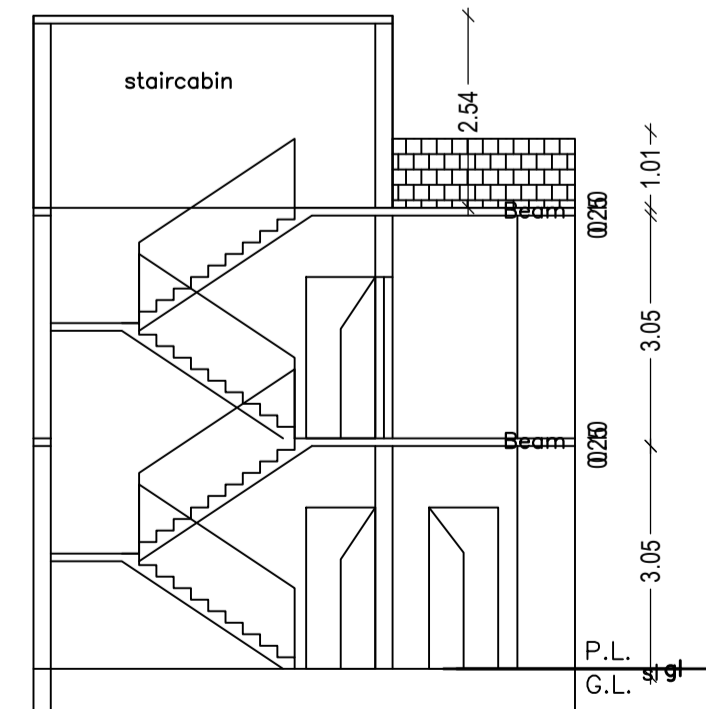

SECTIONAL AT X-X

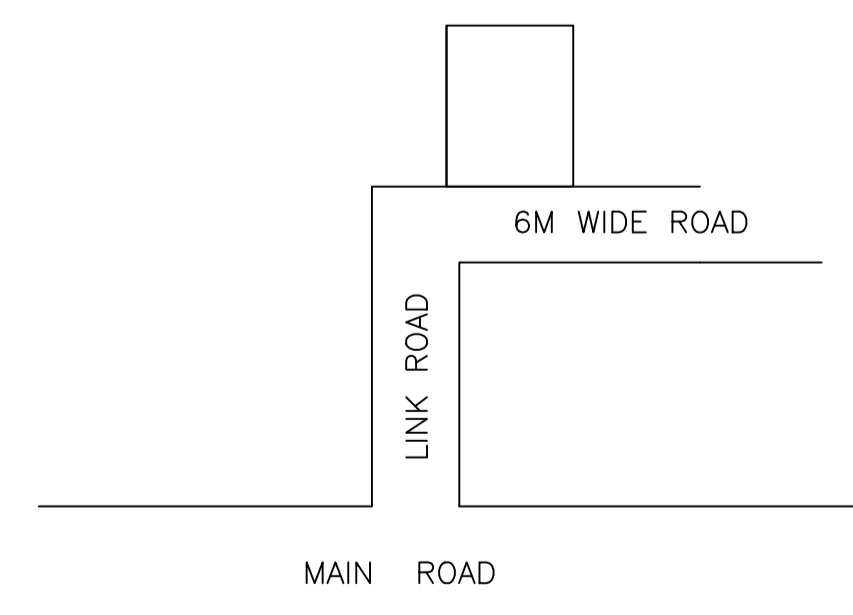

LOCATION

| LTP NAME AND SIGNATURE                    | STRUCTURAL ENG'S NAME AND SIGNATURE | BUILDER NAME AND SIGNATURE | DIGITAL SIGNATURE |
|---|-------------------------------------|----------------------------|-------------------|
| MANOJ KUMAR SINGH<br>MADA/DFTMN/0023/2019 |                                     |                            |                   |