

SITE PLAN  
SCALE - 1 : 8

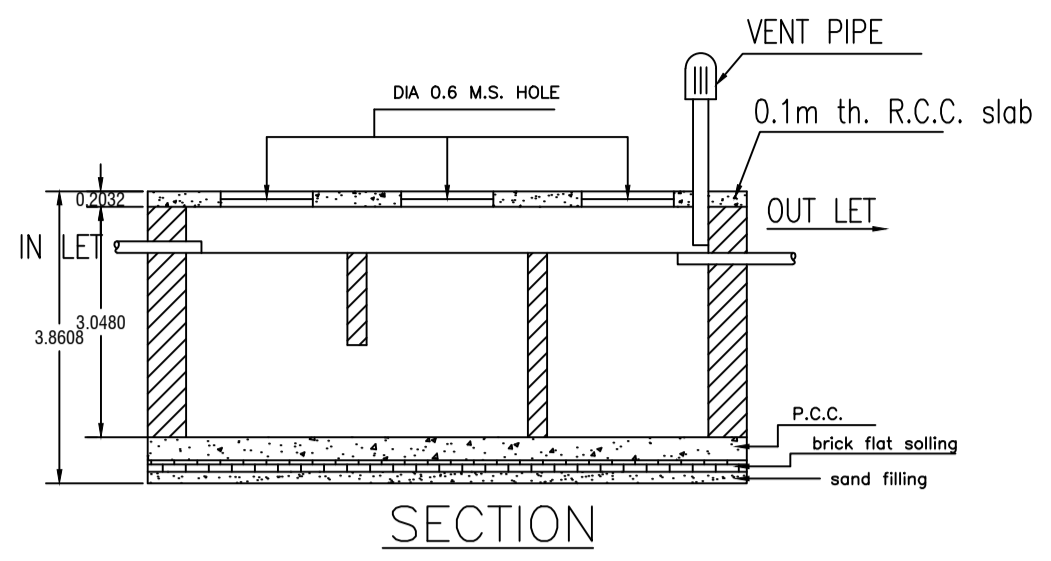

SECTION

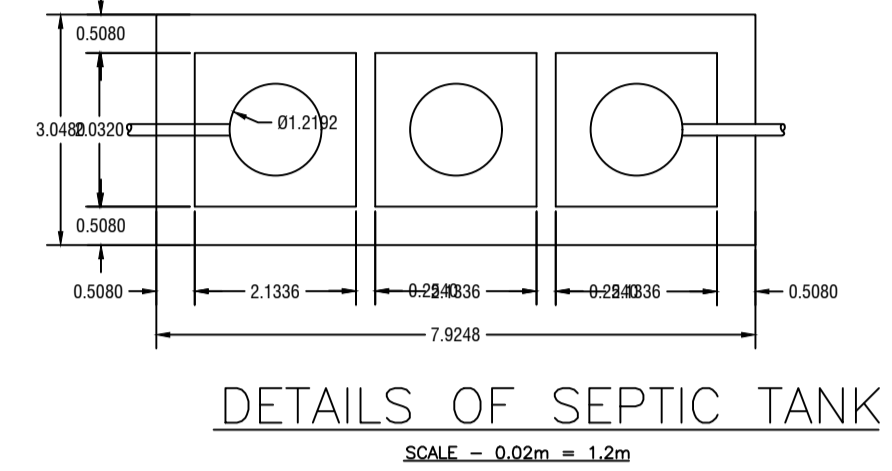

DETAILS OF SEPTIC TANK  
SCALE - 0.02m = 1.2m

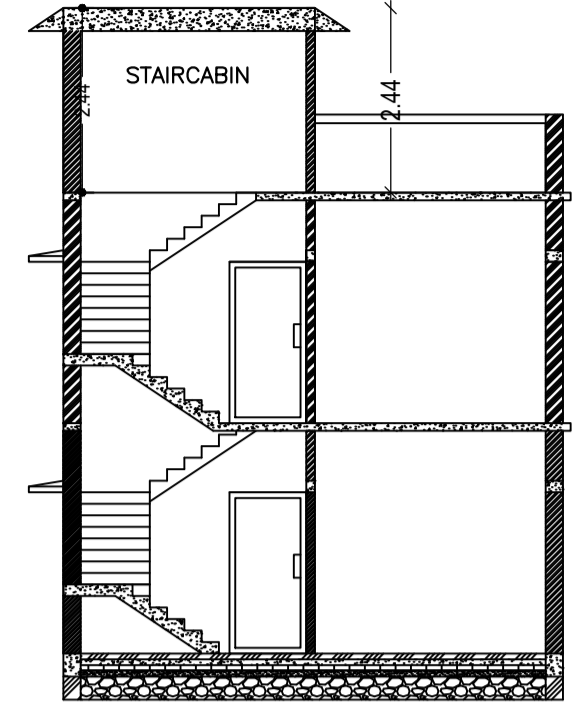

SECTION AT X-X  
SCALE - 1:8

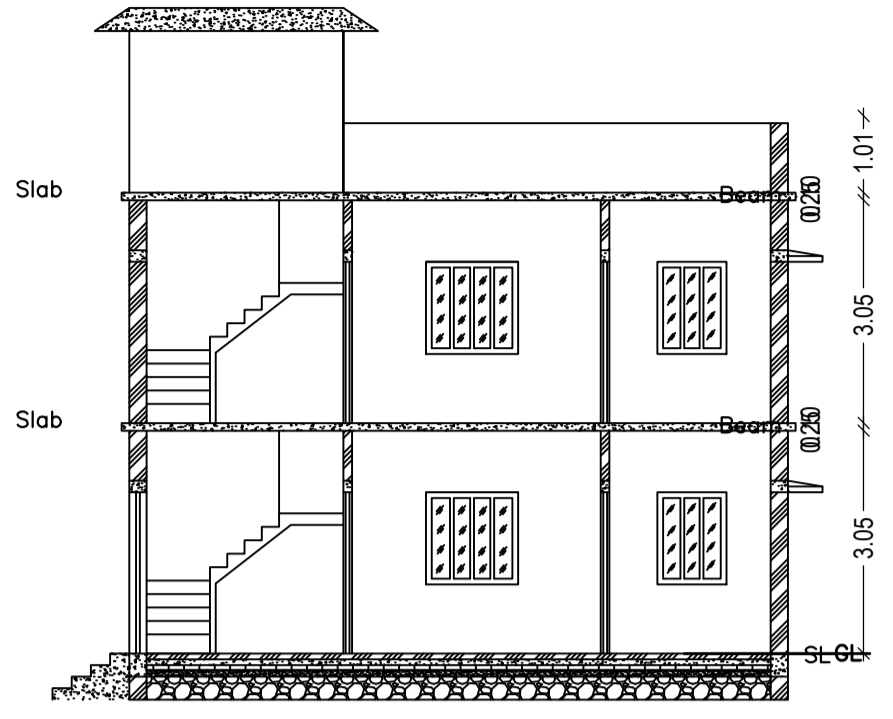

SECTION AT - YY  
SCALE - 1:8

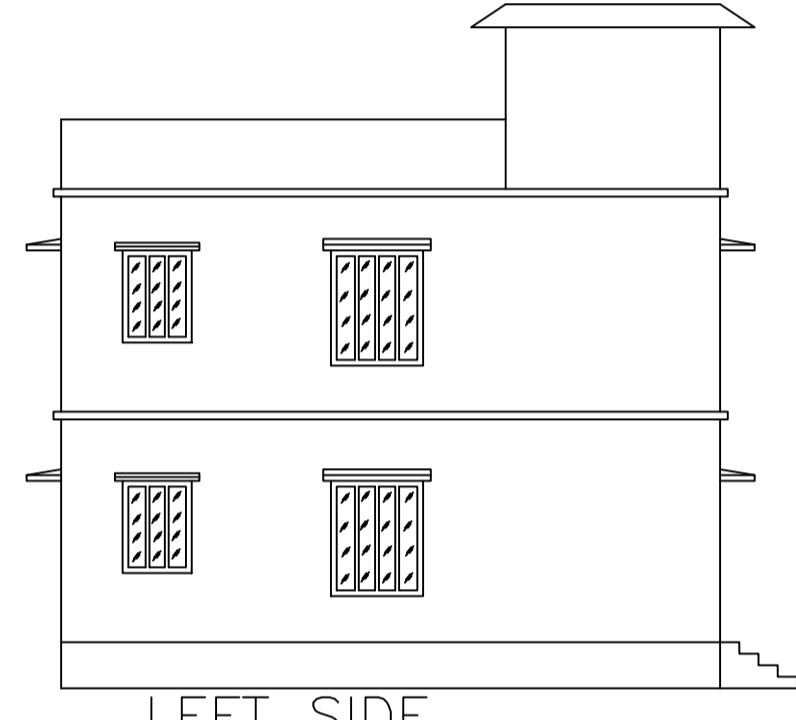

LEFT SIDE ELEVATION  
SCALE - 1:8

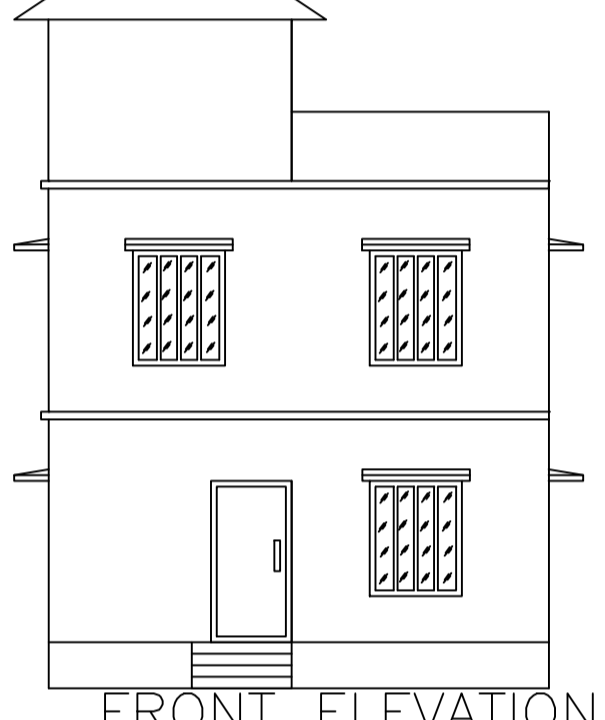

FRONT ELEVATION  
SCALE - 1:8

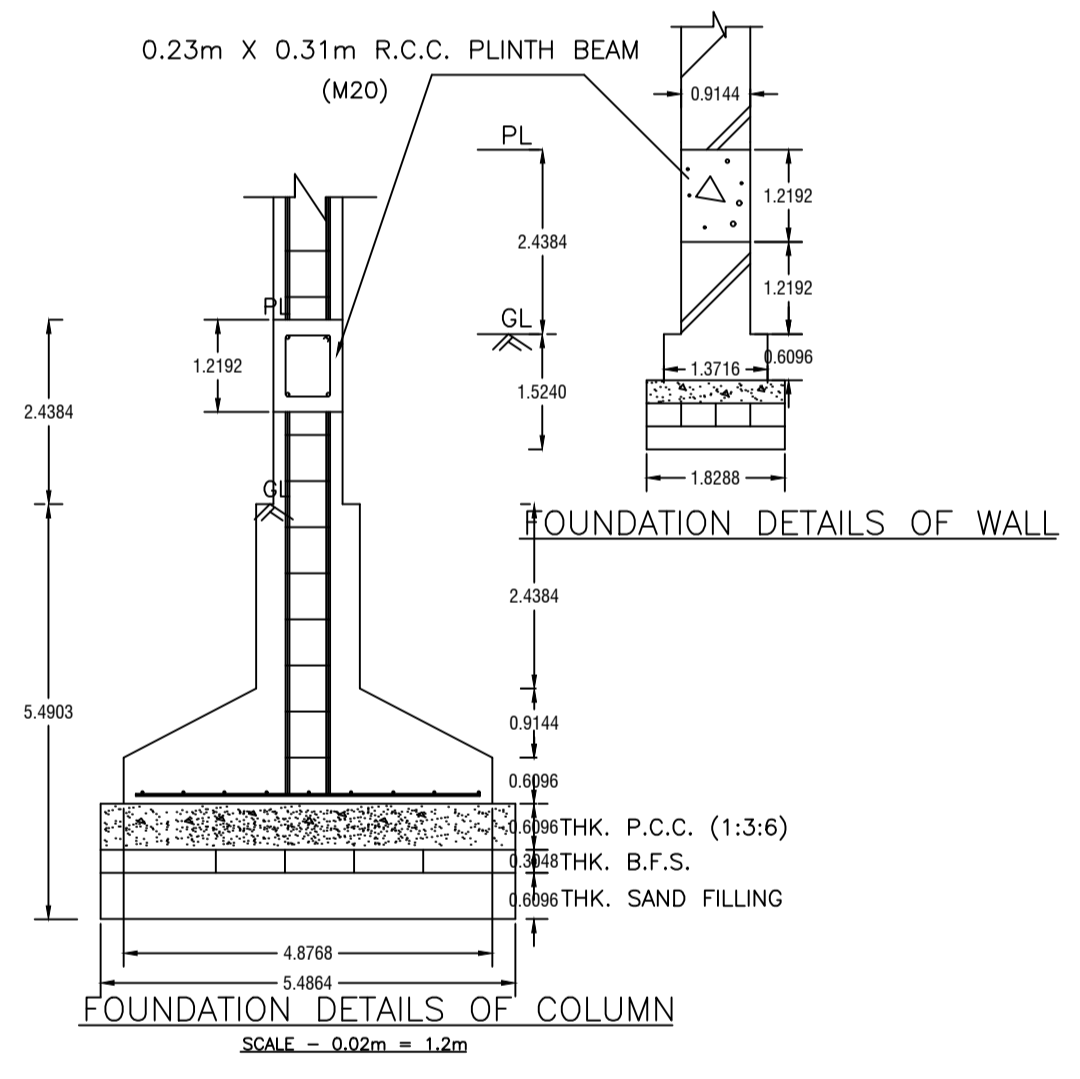

FOUNDATION DETAILS OF WALL

FOUNDATION DETAILS OF COLUMN  
SCALE - 0.02m = 1.2m

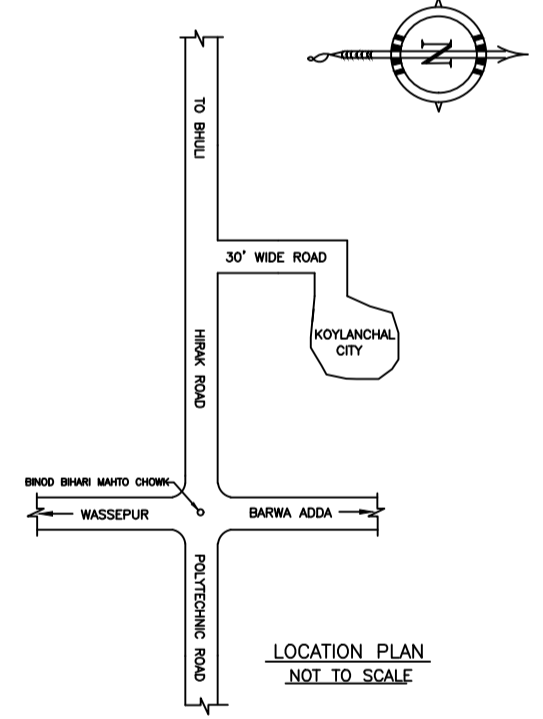

LOCATION PLAN  
NOT TO SCALE

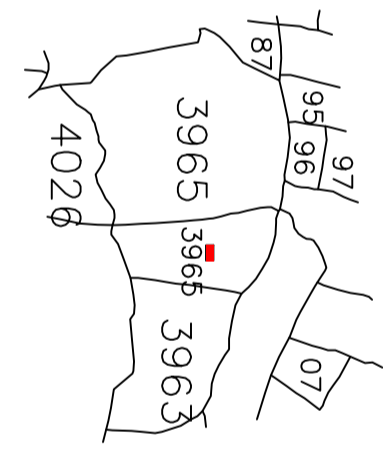

KEY PLAN

SCHEDULE OF DOOR:

BUILDING NAME	NAME	LENGTH	HEIGHT	NOS
A (A)	D	0.81	2.10	07
A (A)	D	0.90	2.10	04

SCHEDULE OF WINDOW/VENTILATION:

BUILDING NAME	NAME	LENGTH	HEIGHT	NOS
A (A)	W	1.10	1.20	02
A (A)	W	1.80	1.20	12

UnitBUA Table for Building :A (A)

FLOOR	Name	UnitBUA Type	UnitBUA Area	Carpet Area	No. of Rooms	No. of Tenement
GROUND FLOOR	SPLIT 1	FLAT	123.62	123.59	5	1
FIRST FLOOR	SPLIT 1	FLAT	0.00	0.00	5	0
Total:	-	-	123.62	123.59	10	1

FAR & Tenement Details (Table 4c-1)

Building	No. of Same Bldg	Total Built Up Area (Sq.mt.)	Proposed FAR Area (Sq.mt.)	Total FAR Area (Sq.mt.)	Total Consumed Additional FAR Area (Sq.mt.)	Tnmt (No.)
A (A)	1	123.62	123.62	123.62	123.62	01
Grand Total:	1	123.62	123.62	123.62	123.62	01

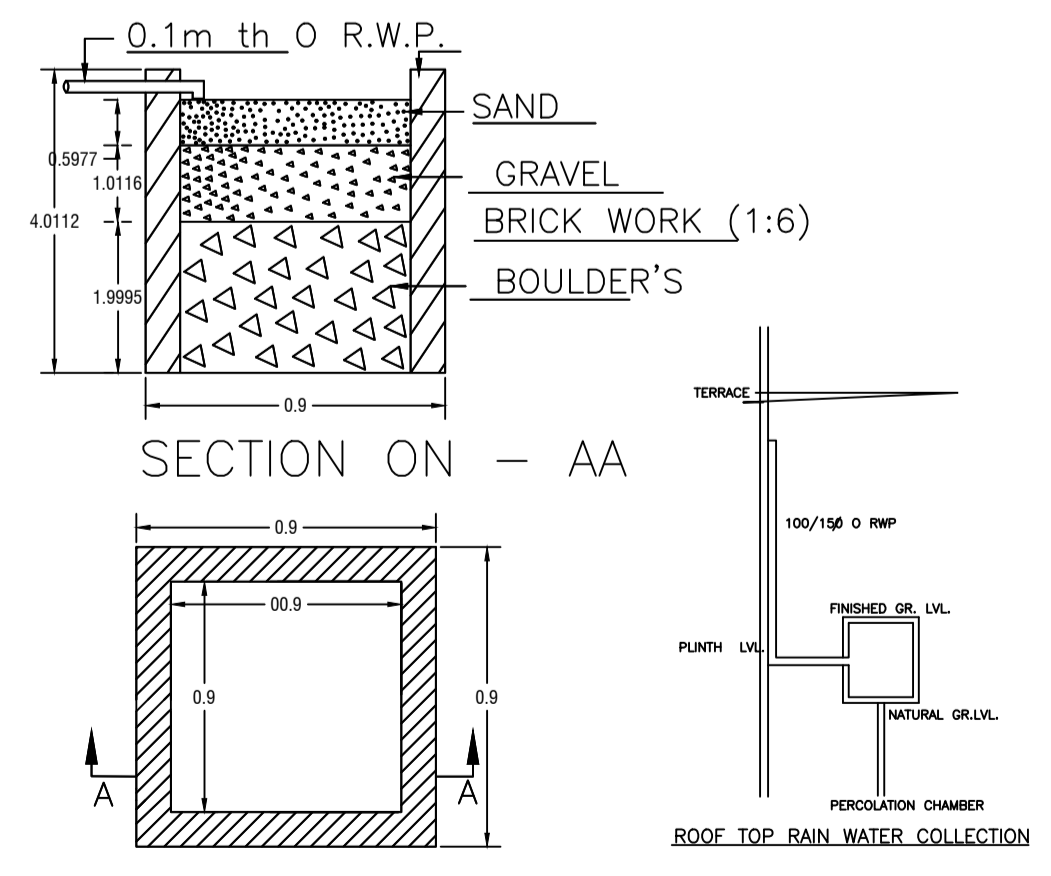

SECTION ON - AA

DETAIL'S OF WATER HARVESTING  
SCALE - 0.02m = 1.2m

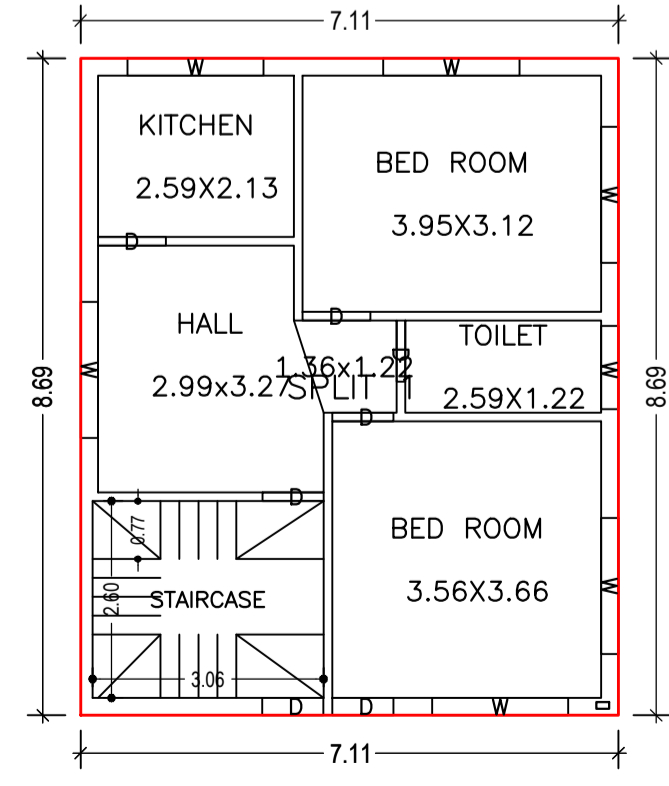

GROUND FLOOR PLAN (Proposed)  
SCALE 1:100

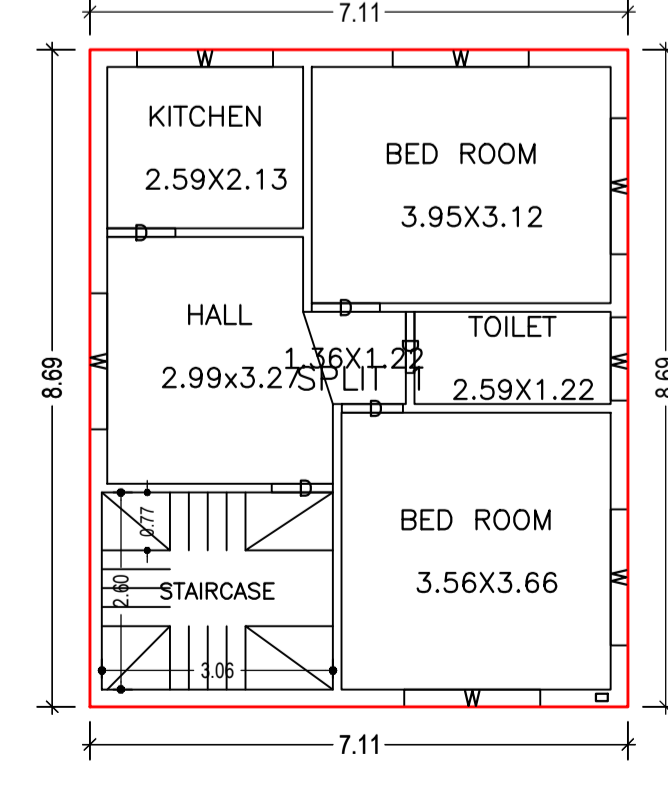

FIRST FLOOR PLAN (Proposed)  
SCALE 1:100

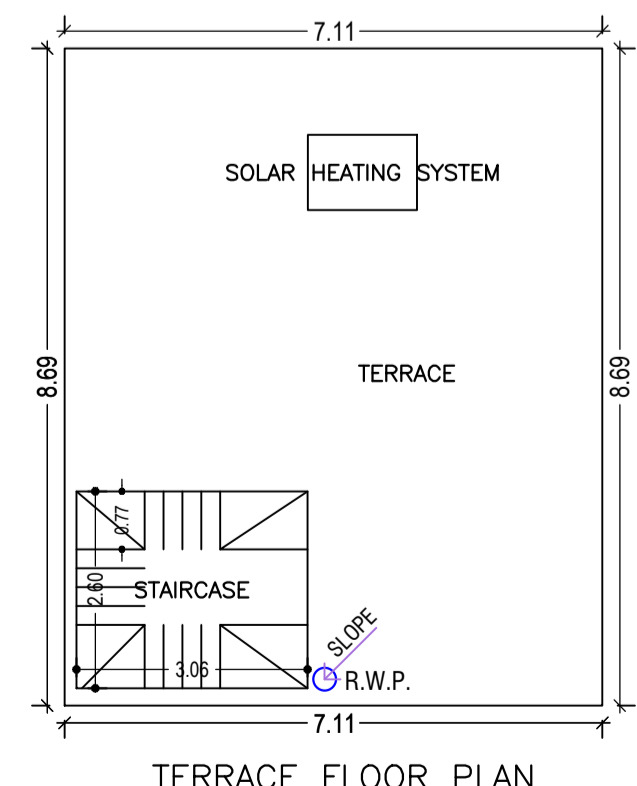

TERRACE FLOOR PLAN (SCALE 1:100)

Proposal Basic Information

Proposal File No.	MADA/BP/0068/2020
Owner Name	SMT. SUDHA SHRIVASTAVA
Khata No	OLD KHATA NO-55, NEW KHATA NO-215
Plot No	OLD PLOT NO. 2527, NEW PLOT NO. 3964
Village Name	Bara Pichari
Use	Residential
SubUse	Bungalow/ Dwelling / Non Apartment

AREA STATEMENT MINERAL AUTHORITY	VERSION NO.: 1.0.53	SQ.MT.
PROJECT DETAIL:	VERSION DATE: 16/10/2020	
Region: JHARKHAND URBAN LOCAL BODIES	Plot Use: Residential	
District: DHANBAD	Plot SubUse: Bungalow/ Dwelling / Non Apartment	
Authority: MINERAL AREA DEVELOPMENT AUTHORITY	PlotNearby/ReligiousStructure: NA	
Inward No: MADA/BP/0068/2020	Plot/SubPlot No: OLD PLOT NO. 2527, NEW PLOT NO. 3964	
Application Type: General Proposal	North: Plot No. - SAME PLOT	
Project Type: Building Permission	South: Plot No. - SAME PLOT	
Nature of Development: New	East: Road Width - 6.0	
Location of Development Area: Old Area	West: Plot No. - SAME PLOT	
AREA OF PLOT (Minimum)	(A)	110.12
NET AREA OF PLOT(Gross Plot Area - Deduction from Gross Plot area)	(A-Deductions)	110.12
Deduction for Balance Plot Area(from Gross Plot Area)		
Common Plot		23.55
Total		23.55
BALANCE AREA OF PLOT(Net Plot Area - Recreational/Amenity space)	(A-Deductions)	86.57
PLOT AREA FOR COVERAGE(Net Plot Area)	(A-Deductions)	110.12
Plot Area for FAR (Net Plot Area + Road/Widening Area)	(A-Deductions)	110.12
COVERAGE CHECK		
Permissible Coverage area ( 70.00 % )		77.08
Proposed Coverage Area ( 56.13 % )		61.81
Total Prop. Coverage Area ( 56.13 % )		61.81
Balance coverage area ( 13.87 % )		15.27
FAR CHECK		
Perm. FAR Area ( 2.50 )		275.30
Total Perm. FAR area		275.30
Residential FAR		123.62
Proposed FAR Area		123.62
Total Proposed FAR Area		123.62
Consumed FAR (Factor)		1.12
Balance FAR Area		151.68
BUILT UP AREA CHECK		
Total Proposed BuiltUp Area		123.62
ARCHITECT (Regd)	RAM PRATAP SINGH	
ENGINEER (Regd)		
SUPERVISOR (Regd)		
OWNER (Regd)	SMT. SUDHA SHRIVASTAVA	
DEVELOPMENT AUTHORITY		LOCAL BODY

COLOR INDEX

PLOT BOUNDARY	Black
ABUTTING ROAD	Green
PROPOSED CONSTRUCTION	Red
COMMON PLOT	Yellow
ROAD WIDENING AREA	Blue
EXISTING (To be retained)	Orange
EXISTING (To be demolished)	Light Blue

Buildingwise Floor FAR Details

Floor Name	Building Name A (A)		Total	
	Proposed Built Up Area (Sq.mt.)	Proposed FAR Area (Sq.mt.)	Total Proposed Built Up Area (Sq.mt.)	Total FAR Area (Sq.mt.)
Ground Floor	61.81	61.81	61.81	61.81
First Floor	61.81	61.81	61.81	61.81
Terrace Floor	0.00	0.00	0.00	0.00
Total:	123.62	123.62	123.62	123.62

Building USE/SUBUSE Details

Building Name A (A)	Building Use Residential	Building SubUse Residential Bldg/Apartment	Building Structure Non-Highrise
A (A)			

Building :A (A)

Floor Name	Total Built Up Area (Sq.mt.)	Proposed FAR Area (Sq.mt.)	Total FAR Area (Sq.mt.)	Total Consumed Additional FAR Area (Sq.mt.)	Tnmt (No.)
Ground Floor	61.81	61.81	61.81	61.81	01
First Floor	61.81	61.81	61.81	61.81	00
Terrace Floor	0.00	0.00	0.00	0.00	00
Total:	123.62	123.62	123.62	123.62	01
Total Number of Same Buildings:	1				
Total:	123.62	123.62	123.62	123.62	01

LTP NAME AND SIGNATURE RAM PRATAP SINGH MADA/ARC/0024/2019	STRUCTURAL ENG'S NAME AND SIGNATURE	BUILDER NAME AND SIGNATURE	DIGITAL SIGNATURE
--	-------------------------------------	----------------------------	-------------------