

SITE PLAN

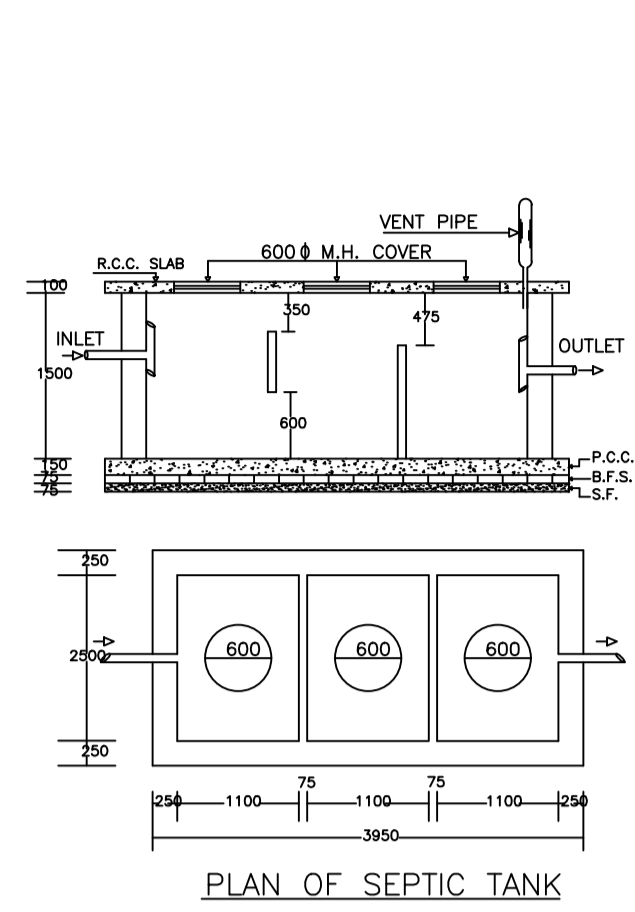

PLAN OF SEPTIC TANK

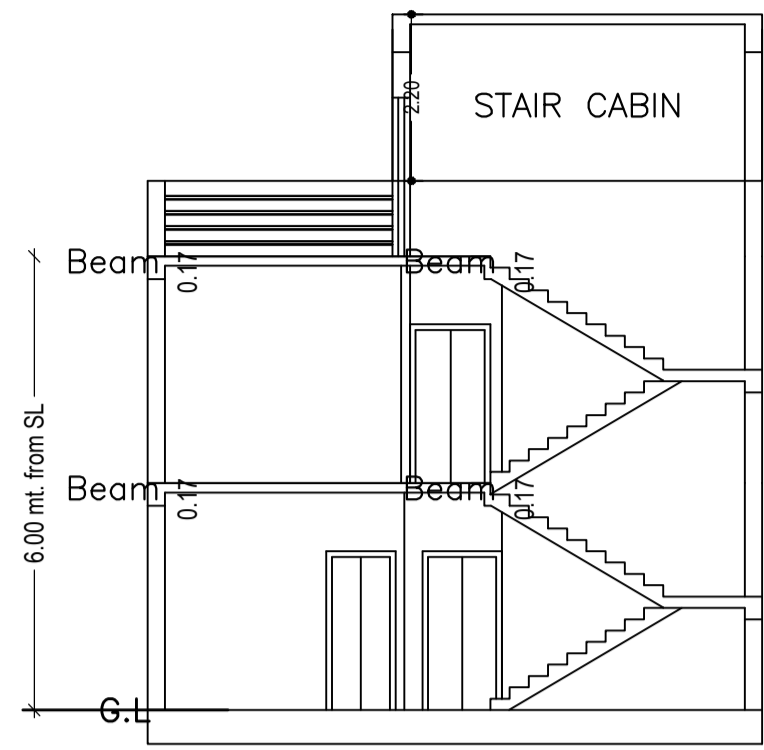

SECTION AT X-X

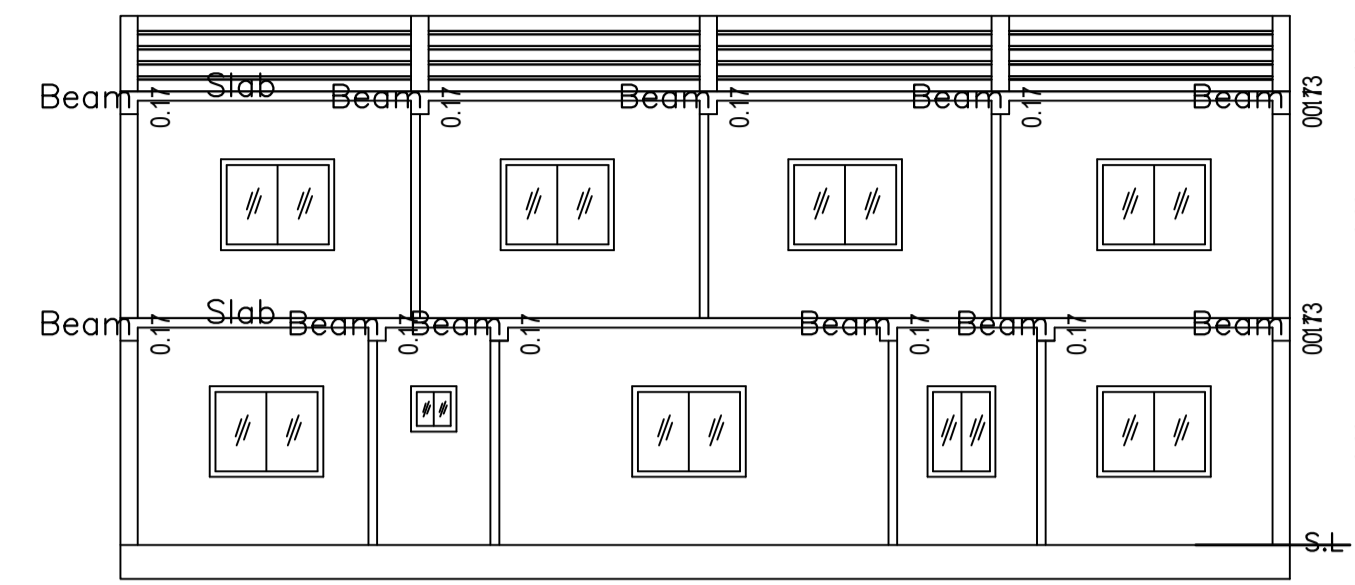

SECTION AT Y-Y

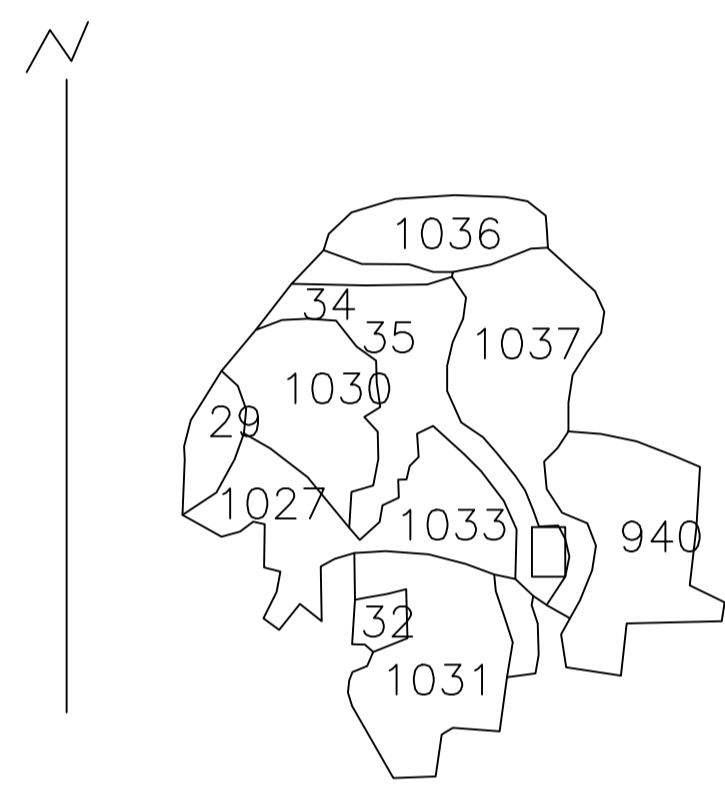

KEY PLAN

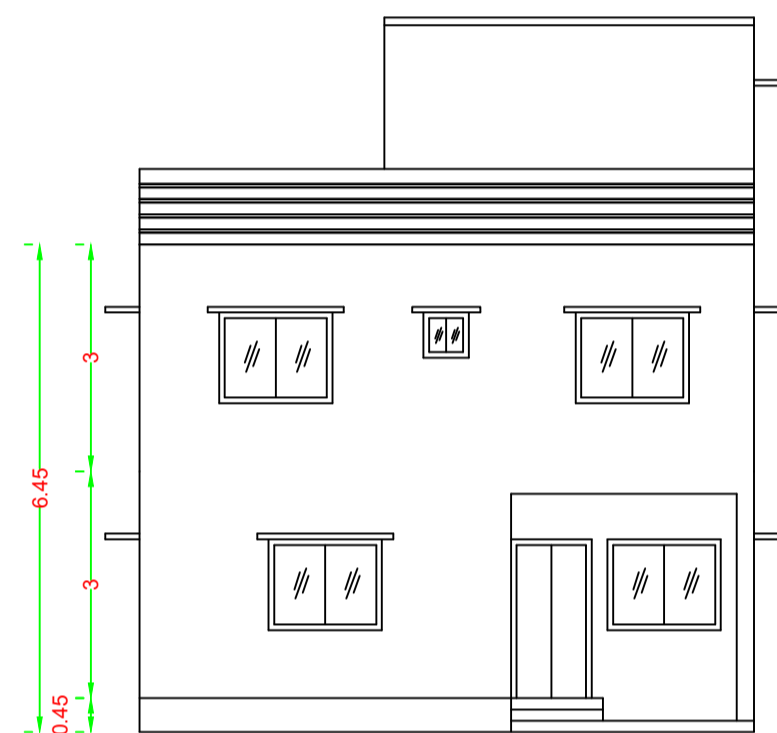

FRONT ELEVATION

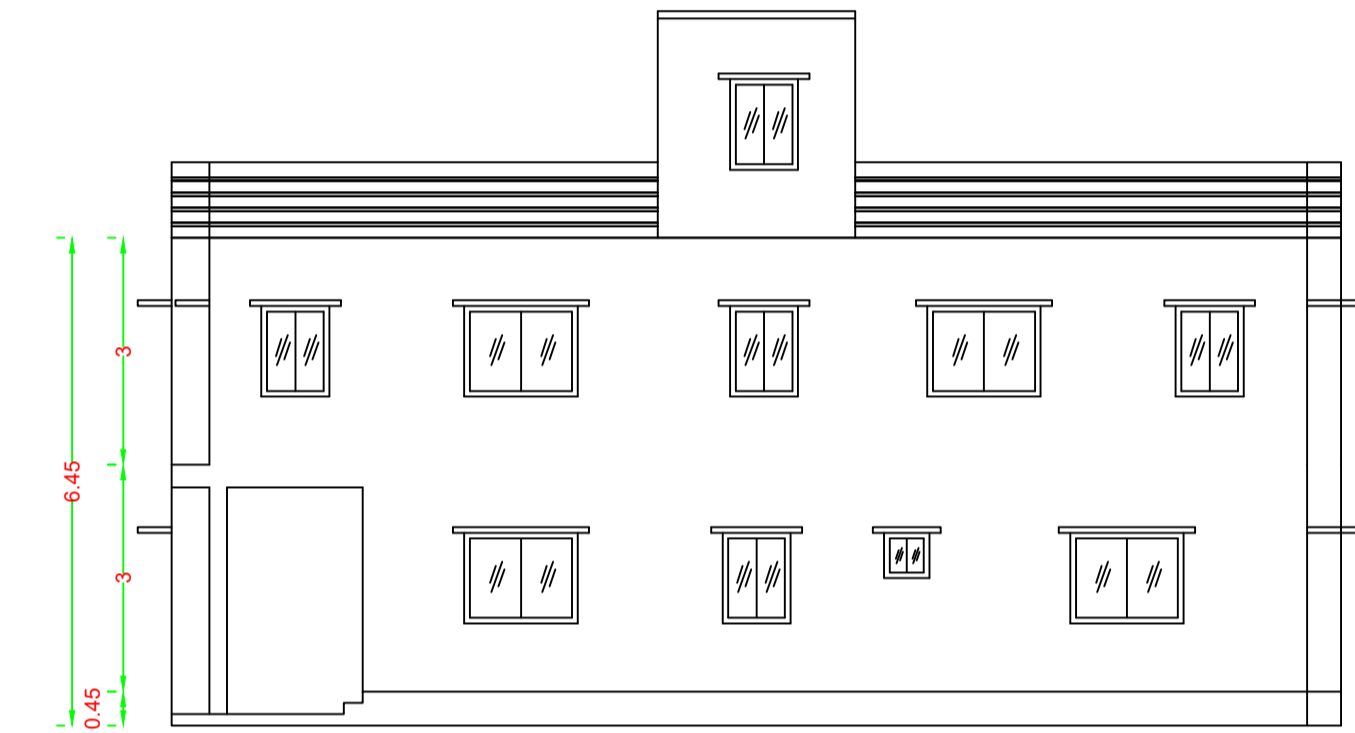

RIGHT SIDE ELEVATION

SCHEDULE OF DOOR:

BUILDING NAME	NAME	LENGTH	HEIGHT	NOS
A (B)	D	0.75	2.10	08
A (B)	D1	0.90	2.10	03
A (B)	D2	1.00	2.10	11
A (B)	D3	1.00	2.10	01

SCHEDULE OF WINDOW/VENTILATION:

BUILDING NAME	NAME	LENGTH	HEIGHT	NOS
A (B)	V	0.60	0.60	04
A (B)	W	0.90	1.20	03
A (B)	W1	1.20	1.20	03
A (B)	W2	1.50	1.20	19

UnitBUA Table for Building :A (B)

FLOOR	Name	UnitBUA Type	UnitBUA Area	Carpet Area	No. of Rooms	No. of Tenement
GROUND FLOOR PLAN	SPLIT 1	FLAT	245.43	245.33	11	1
FIRST FLOOR PLAN	SPLIT 1	FLAT	0.00	0.00	11	0
Total:	-	-	245.43	245.33	22	1

FAR & Tenement Details (Table 4c-1)

Building	No. of Same Bldg	Total Built Up Area (Sq.mt.)	Proposed FAR Area (Sq.mt.) Resi.	Total FAR Area (Sq.mt.)	Total Consumed Additional FAR Area (Sq.mt.)	Trmt (No.)
A (B)	1	245.44	245.44	245.44	245.44	01
Grand Total:	1	245.44	245.44	245.44	245.44	01

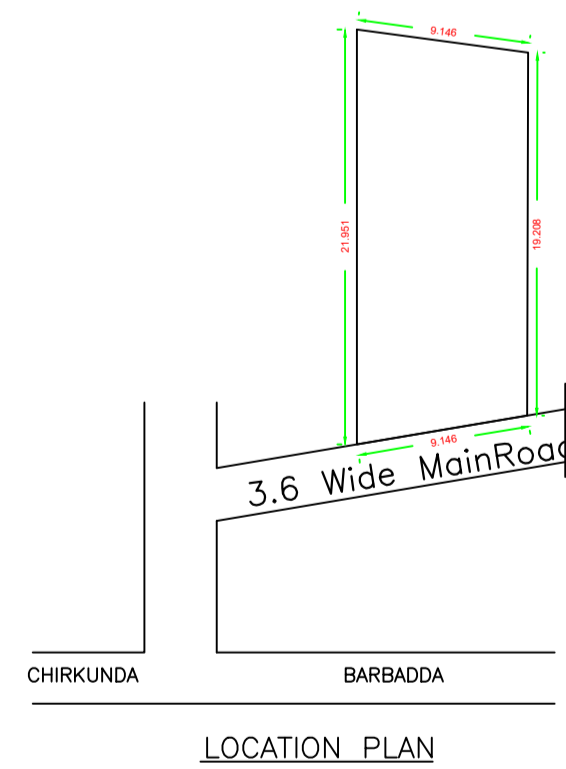

LOCATION PLAN

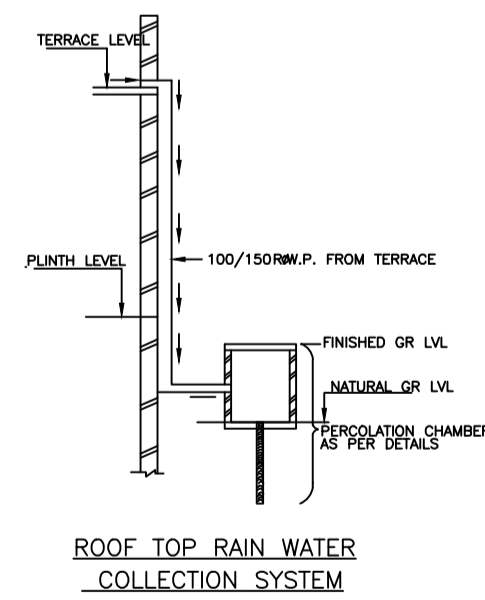

ROOF TOP RAIN WATER COLLECTION SYSTEM

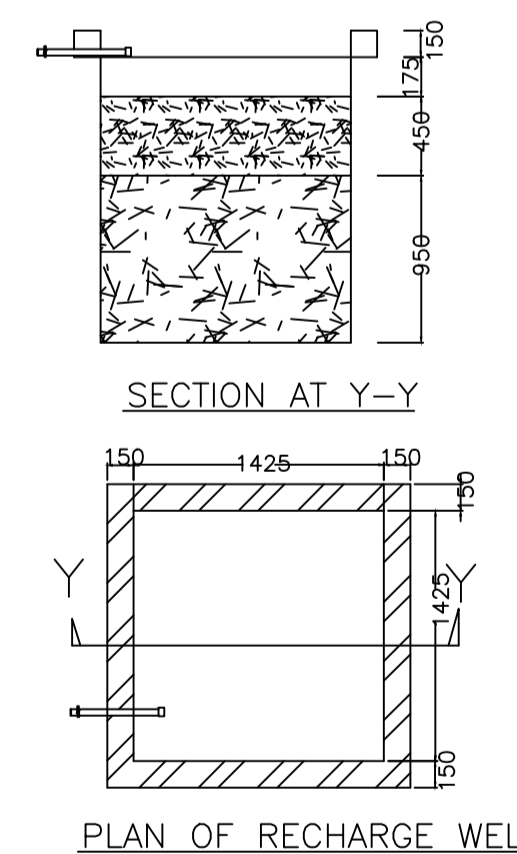

PLAN OF RECHARGE WELL

WATER HARVESTING

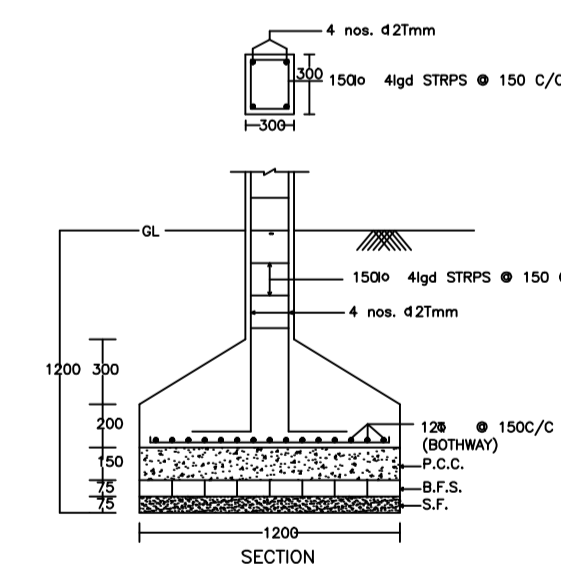

DETAIL OF COLUMNS

Proposal Basic Information

Proposal File No.	MADA/0093/2020
Owner Name	PUSHPA RAY
Khata No	67 (O) 346 (N)
Plot No	1034, 1037 (O) 1464, 1468 (N)
Village Name	Karmatanr
Use	Residential
SubUse	Bungalow/ Dwelling / Non Apartment

AREA STATEMENT MINERAL AREA DEVELOPMENT AUTHORITY	VERSION NO. : 1.0.53	VERSION DATE: 16/10/2020
PROJECT DETAIL:		
Region: JHARKHAND URBAN LOCAL BODIES	Plot Use: Residential	
District: DHANBAD	Plot SubUse: Bungalow/ Dwelling / Non Apartment	
Authority: MINERAL AREA DEVELOPMENT AUTHORITY	Plot/Nearby/Religious/Structure: NA	
Inward No: MADA/BP/0093/2020	Plot/SubPlot No: 1034, 1037 (O) 1464, 1468 (N)	
Application Type: General Proposal	North: Road Width - 3.66	
Project Type: Building Permission	South: Plot No. - MOHAMMAD HUSAIN	
Nature of Development: New	East: Plot No. - MOHAMMAD HUSAIN	
Location of Development Area: Old Area	West: Plot No. - GYANESHWAR SHARMA AND ALOK KUMAR PANDEY	
AREA DETAILS:		
AREA OF PLOT (Minimum)	(A)	SQ.MT. 185.97
NET AREA OF PLOT(Gross Plot Area - Deduction from Gross Plot area)	(A-Deductions)	185.97
Deduction for Balance Plot Area(from Gross Plot Area)		
Common Plot		43.88
Total		43.88
BALANCE AREA OF PLOT(Net Plot Area - Recreational/Amenity space)	(A-Deductions)	142.09
PLOT AREA FOR COVERAGE(Net Plot Area)	(A-Deductions)	185.97
Plot Area for FAR (Net Plot Area + Road/Widening Area)	(A-Deductions)	185.97
COVERAGE CHECK		
Permissible Coverage area ( 70.00 % )		130.18
Proposed Coverage Area ( 65.99 % )		122.72
Total Prop. Coverage Area ( 65.99 % )		122.72
Balance coverage area ( 4.01 % )		7.46
FAR CHECK		
Perm. FAR Area ( 1.50 )		278.96
Total Perm. FAR area		278.96
Residential FAR		245.43
Proposed FAR Area		245.43
Total Proposed FAR Area		245.43
Consumed FAR (Factor)		1.32
Balance FAR Area		33.53
BUILT UP AREA CHECK		
Total Proposed BuiltUp Area		245.44
ARCHITECT (Regd)	Partha Pal	
ENGINEER (Regd)		
SUPERVISOR (Regd)		
OWNER (Regd)	PUSHPA RAY	
DEVELOPMENT AUTHORITY		LOCAL BODY

COLOR INDEX

PLOT BOUNDARY	Black
ABUTTING ROAD	Green
PROPOSED CONSTRUCTION	Red
COMMON PLOT	Yellow
ROAD WIDENING AREA	Blue
EXISTING (To be retained)	Orange
EXISTING (To be demolished)	Light Blue

Buildingwise Floor FAR Details

Floor Name	Building Name A (B)		Total	
	Proposed Built Up Area (Sq.mt.)	Proposed FAR Area (Sq.mt.)	Total Proposed Built Up Area (Sq.mt.)	Total FAR Area (Sq.mt.)
Ground Floor	122.72	122.72	122.72	122.72
First Floor	122.72	122.72	122.72	122.72
Terrace Floor	0.00	0.00	0.00	0.00
Total:	245.44	245.44	245.44	245.44

Building USE/SUBUSE Details

Building Name	Building Use	Building SubUse	Building Structure
A (B)	Residential	Bungalow/ Dwelling / Non Apartment	Non-Highrise

Building :A (B)

Floor Name	Total Built Up Area (Sq.mt.)	Proposed FAR Area (Sq.mt.) Resi.	Total FAR Area (Sq.mt.)	Total Consumed Additional FAR Area (Sq.mt.)	Trmt (No.)
Ground Floor	122.72	122.72	122.72	122.72	01
First Floor	122.72	122.72	122.72	122.72	00
Terrace Floor	0.00	0.00	0.00	0.00	00
Total:	245.44	245.44	245.44	245.44	01
Total Number of Same Buildings	1				
Total:	245.44	245.44	245.44	245.44	01

LTP NAME AND SIGNATURE	STRUCTURAL ENG'S NAME AND SIGNATURE	BUILDER NAME AND SIGNATURE	DIGITAL SIGNATURE
Partha Pal MADA/ENG/0002/2019			

Proposal Basic Information

Proposal File No.	MADA/EP/0093/2020
Owner Name	PUSHPA ROY
Khata No	67 (O) 346 (N)
Plot No	1034, 1037 (O) 1464, 1468 (N)
Village Name	Karmatanr
Use	Residential
SubUse	Bungalow/ Dwelling / Non Apartment

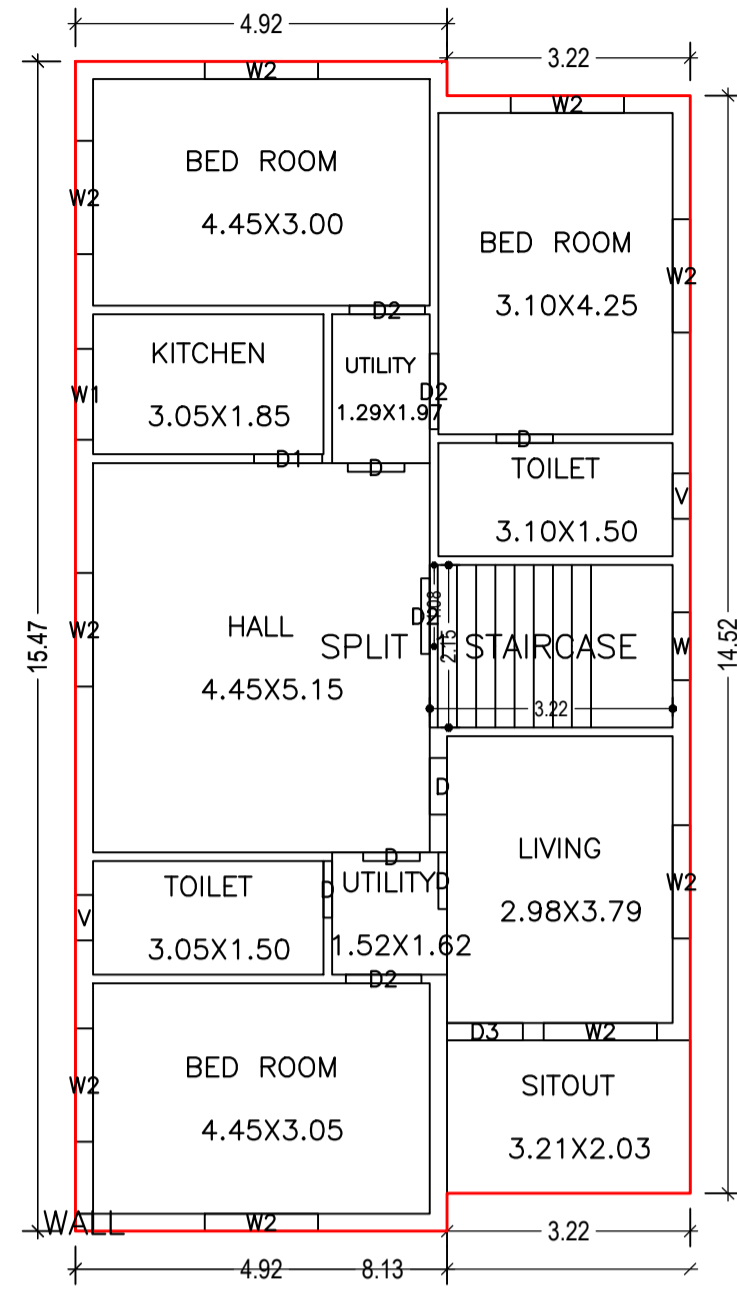

GROUND FLOOR PLAN  
(Proposed)  
(SCALE 1:100)

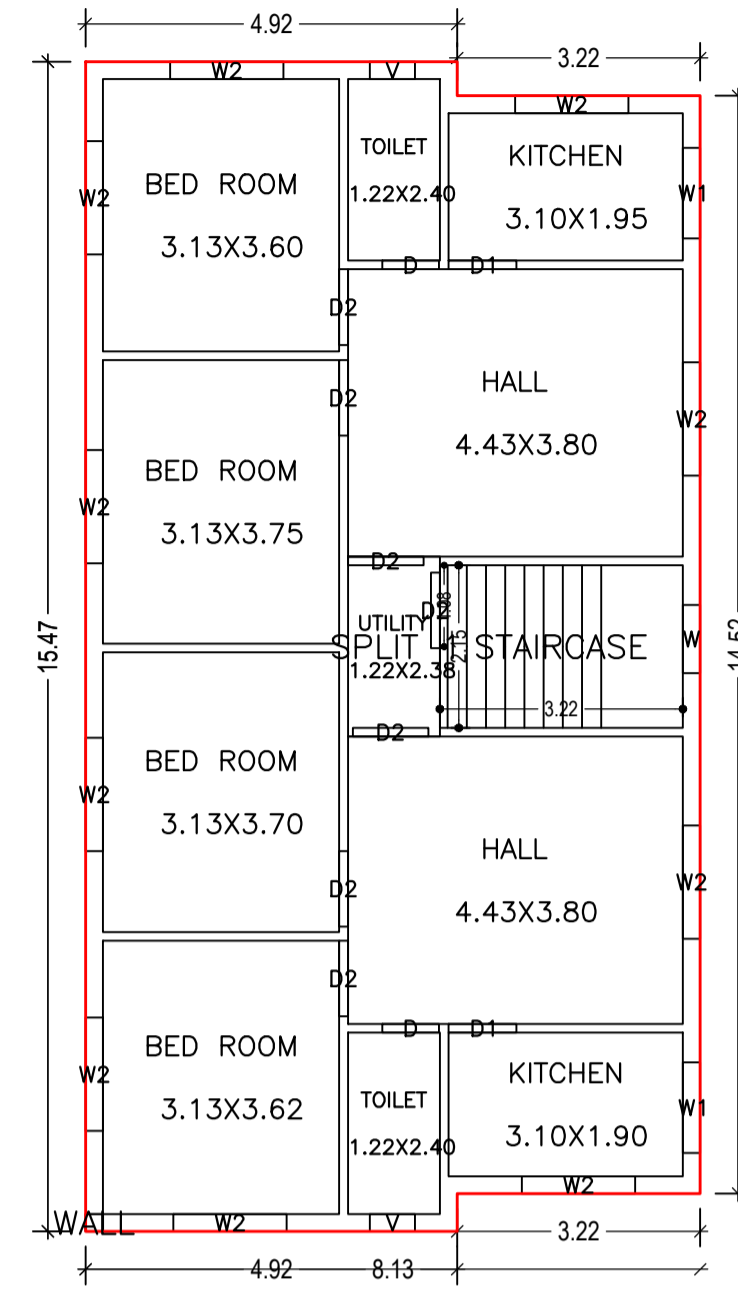

FIRST FLOOR PLAN  
(Proposed)  
(SCALE 1:100)

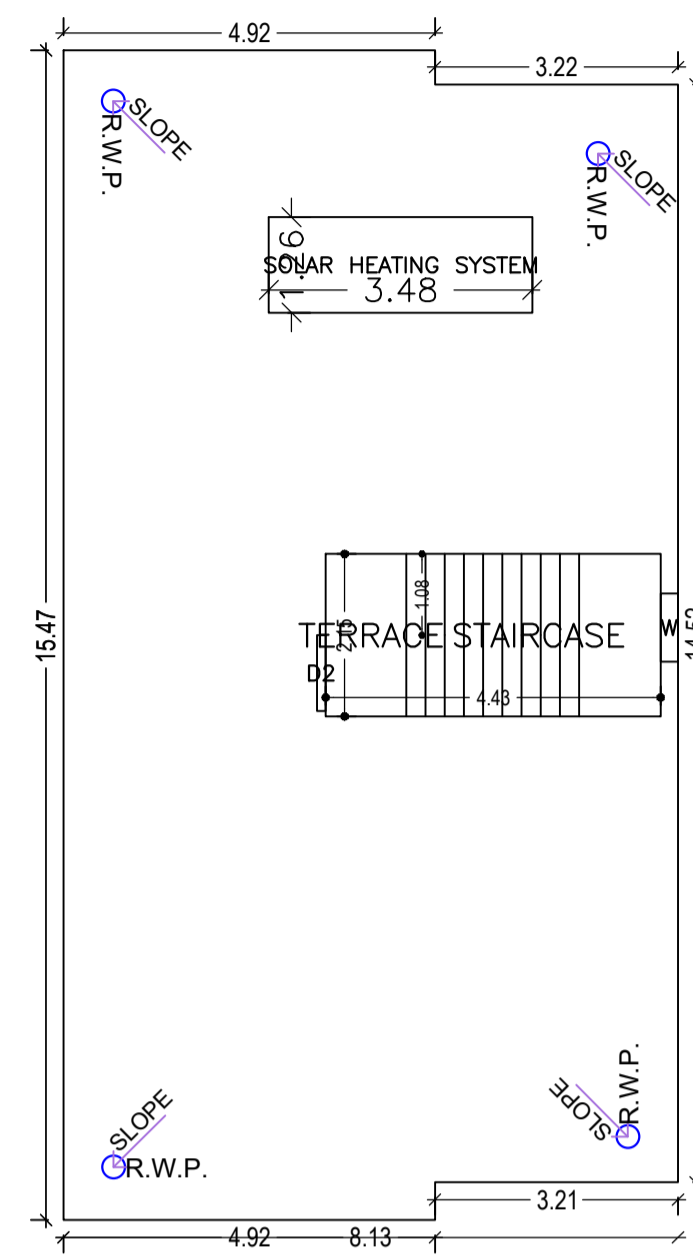

TERRACE FLOOR PLAN  
(Proposed)  
(SCALE 1:100)

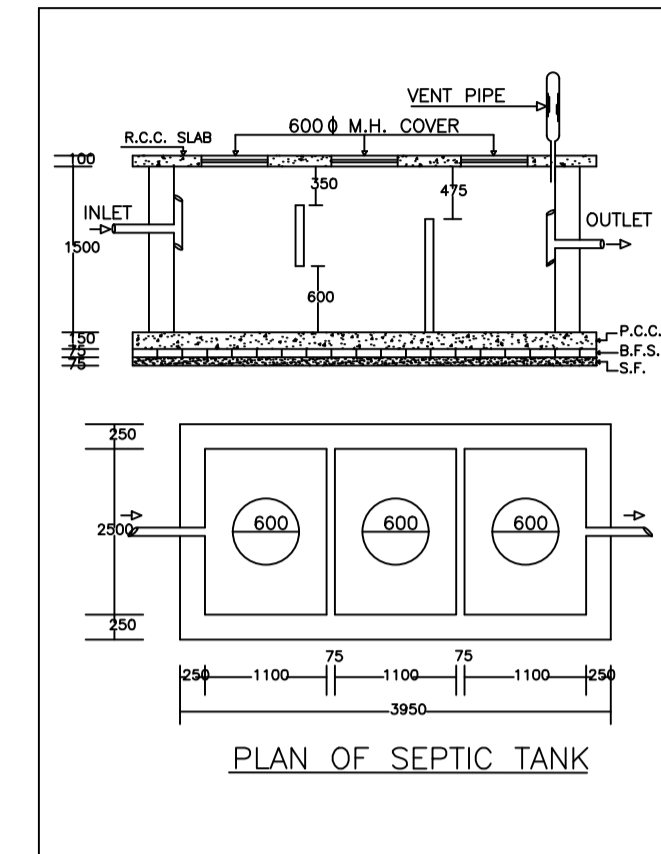

PLAN OF SEPTIC TANK

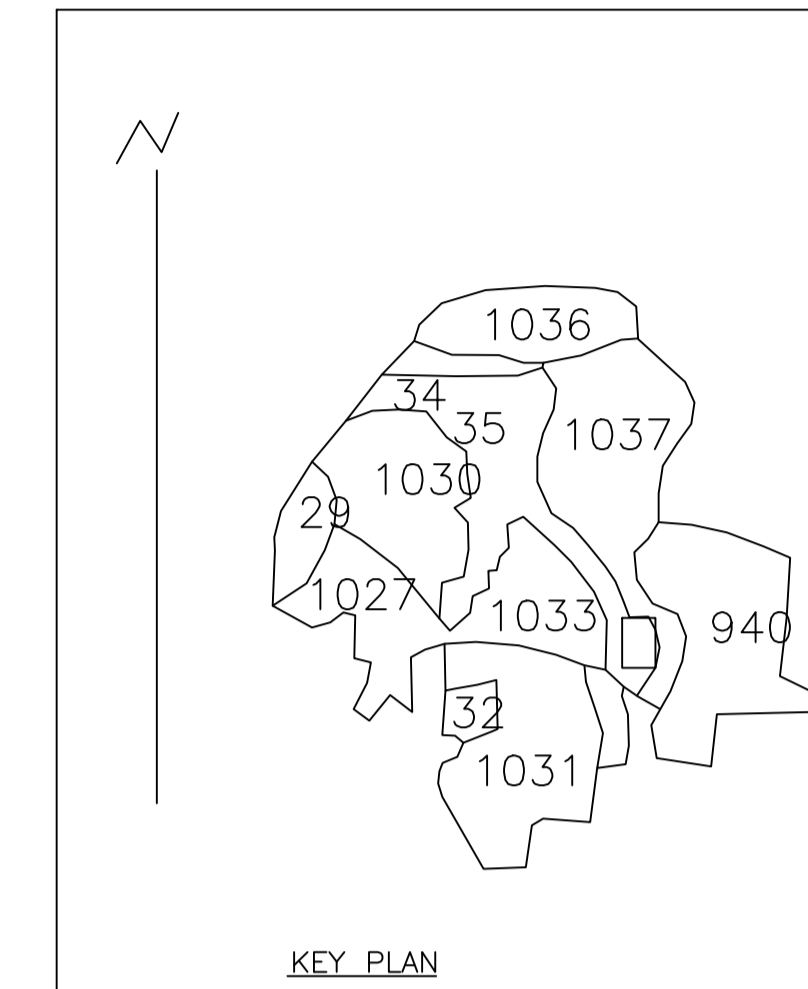

KEY PLAN

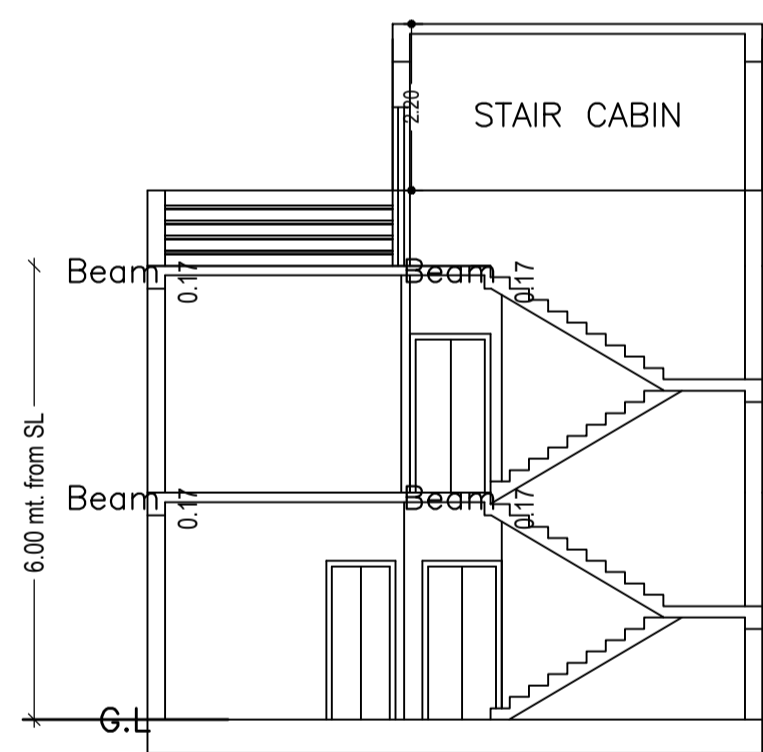

SECTION AT X-X

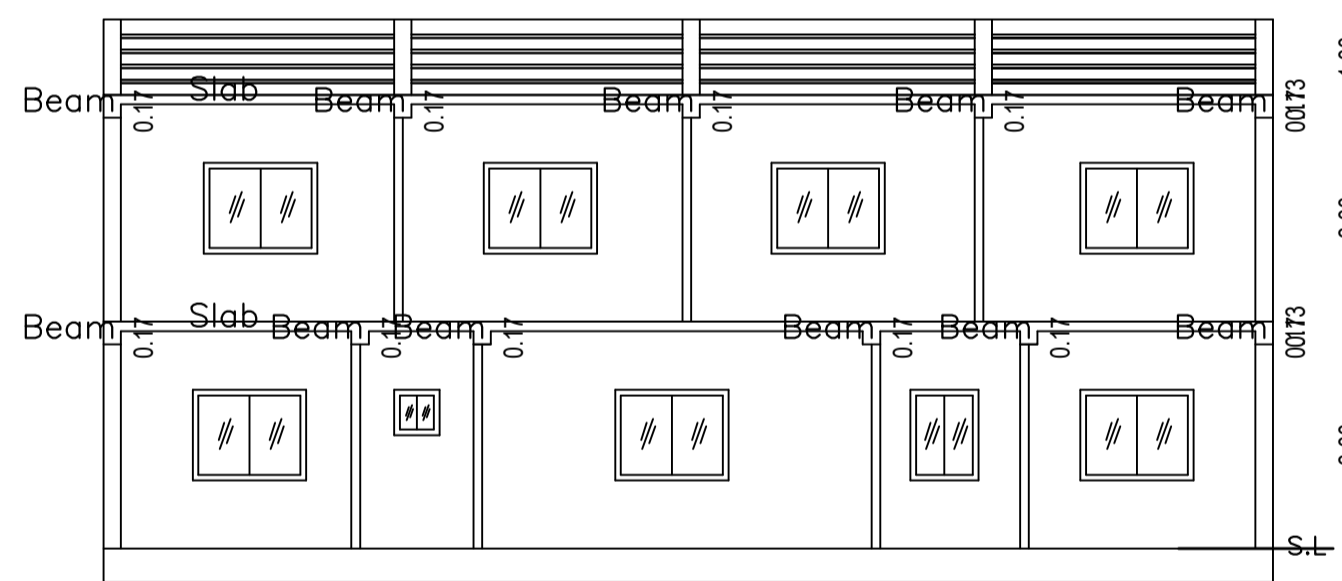

SECTION AT Y-Y

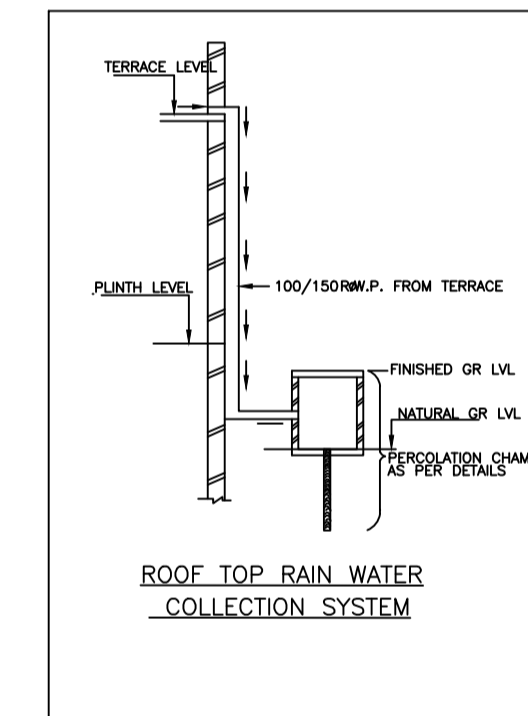

ROOF TOP RAIN WATER  
COLLECTION SYSTEM

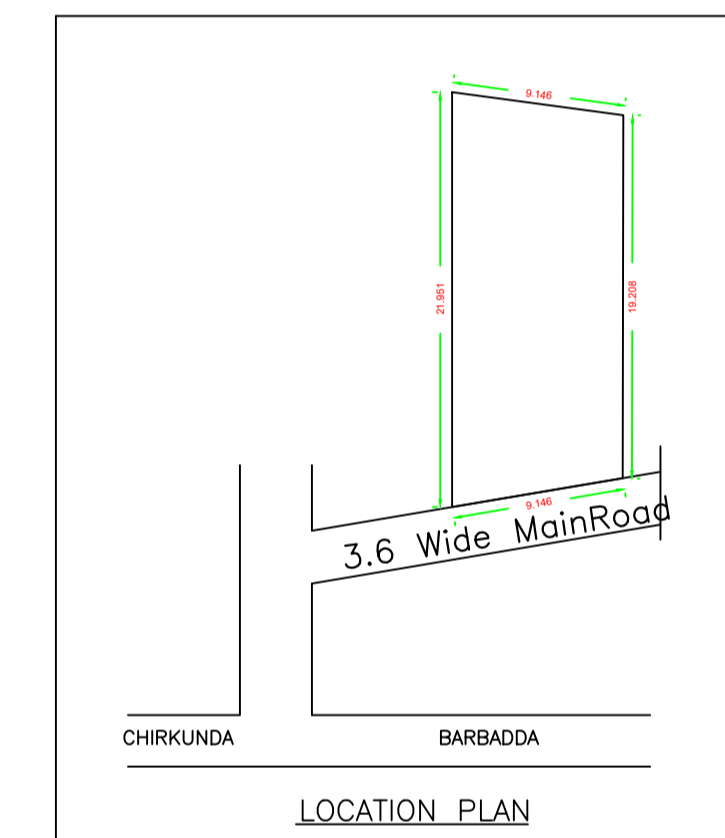

LOCATION PLAN

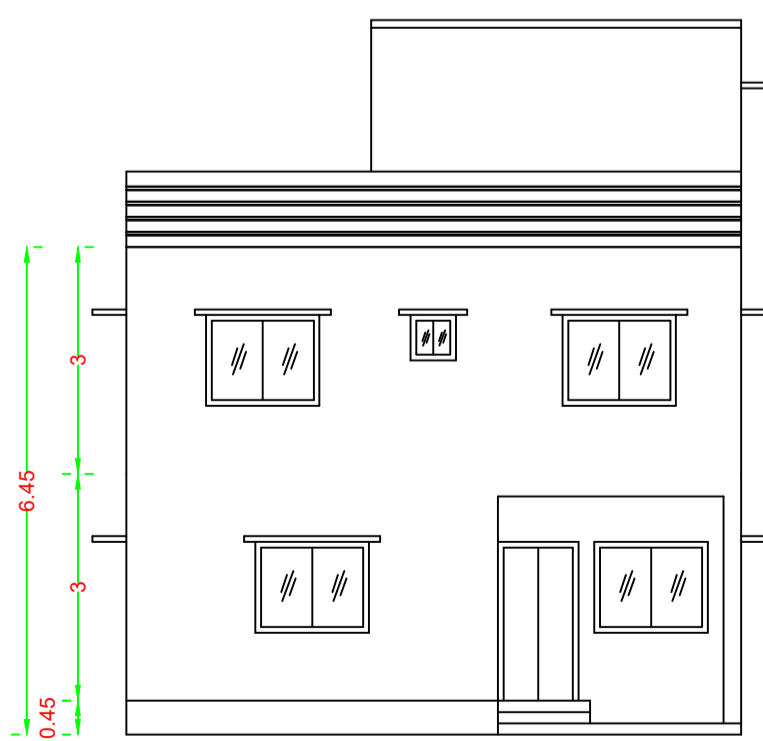

FRONT ELEVATION

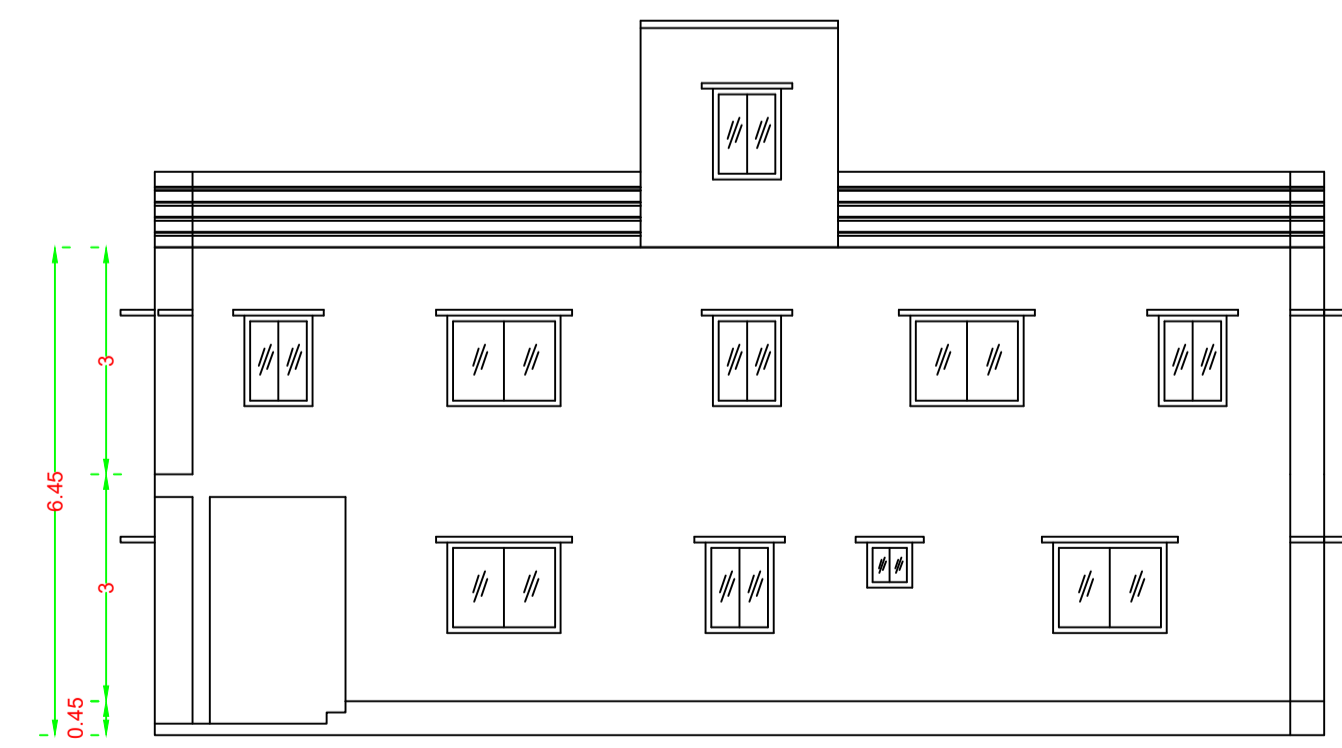

RIGHT SIDE ELEVATION

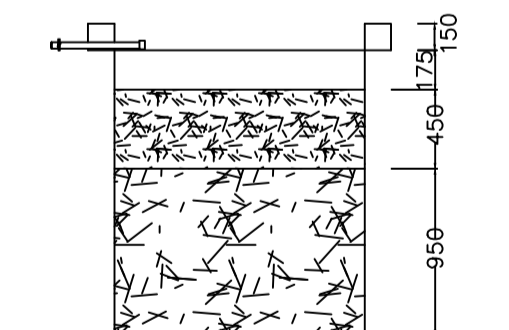

SECTION AT Y-Y

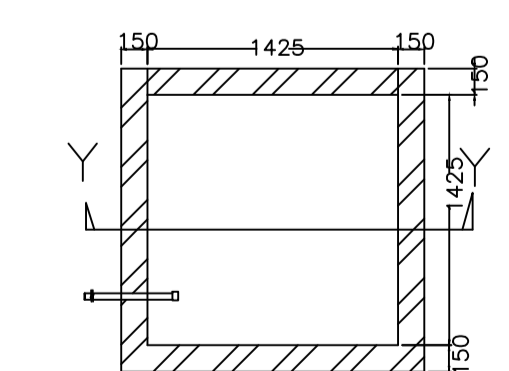

PLAN OF RECHARGE WELL

WATER HARVESTING

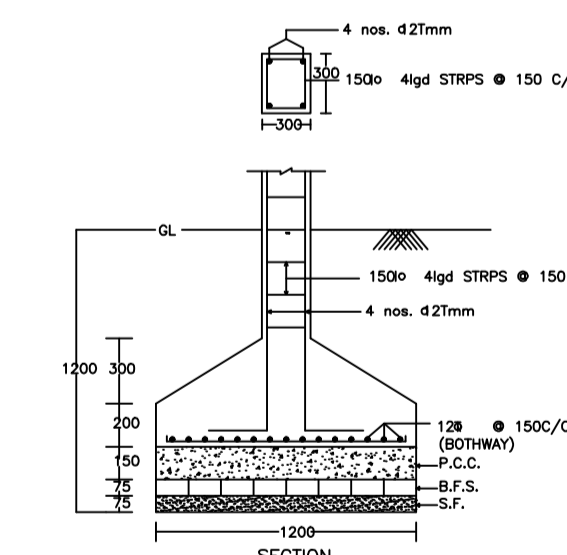

DETAIL OF COLUMNS

LTP NAME AND SIGNATURE Partha Pal MADA/ENG/0002/2019	STRUCTURAL ENG'S NAME AND SIGNATURE	BUILDER NAME AND SIGNATURE	DIGITAL SIGNATURE
--	-------------------------------------	----------------------------	-------------------