

**SITE PLAN**  
1"=8'

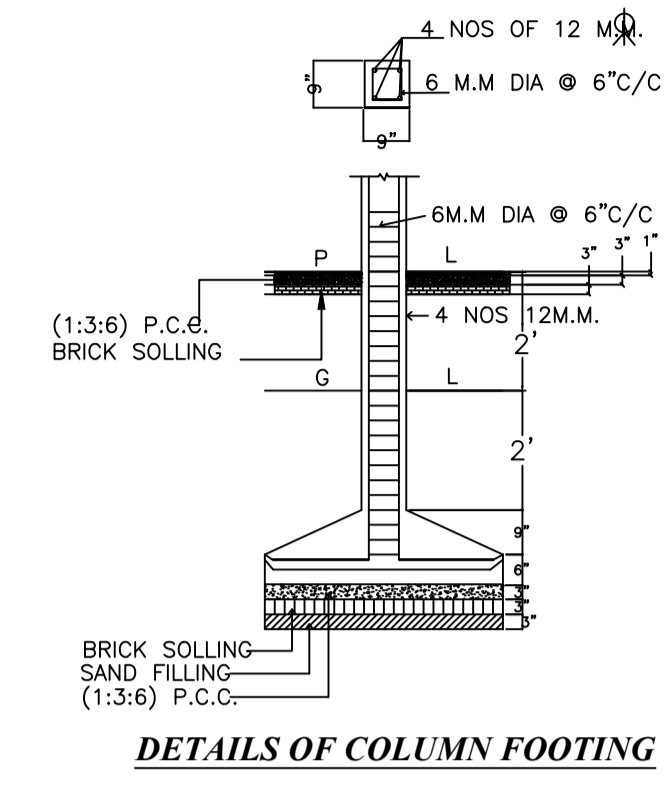

**DETAILS OF COLUMN FOOTING**

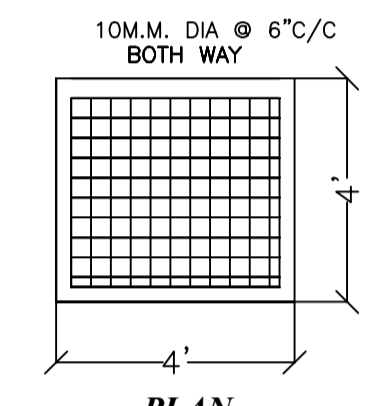

**PLAN**

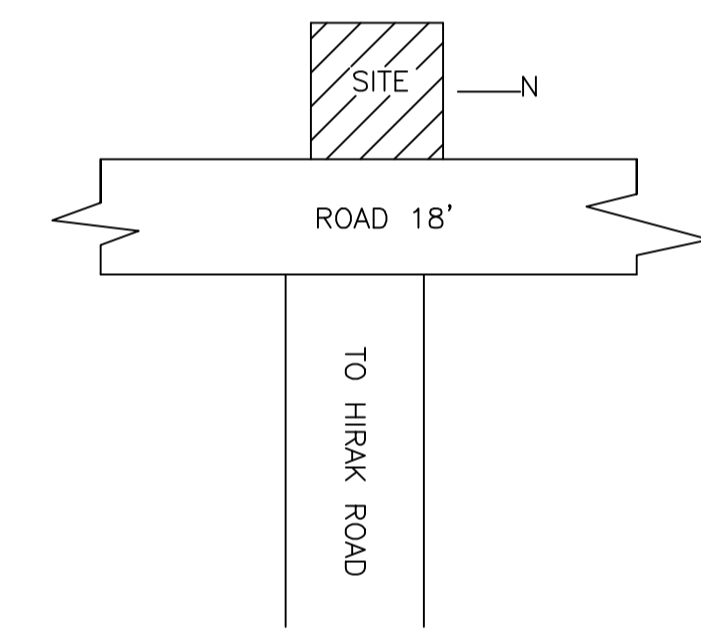

**LOCATION PLAN**

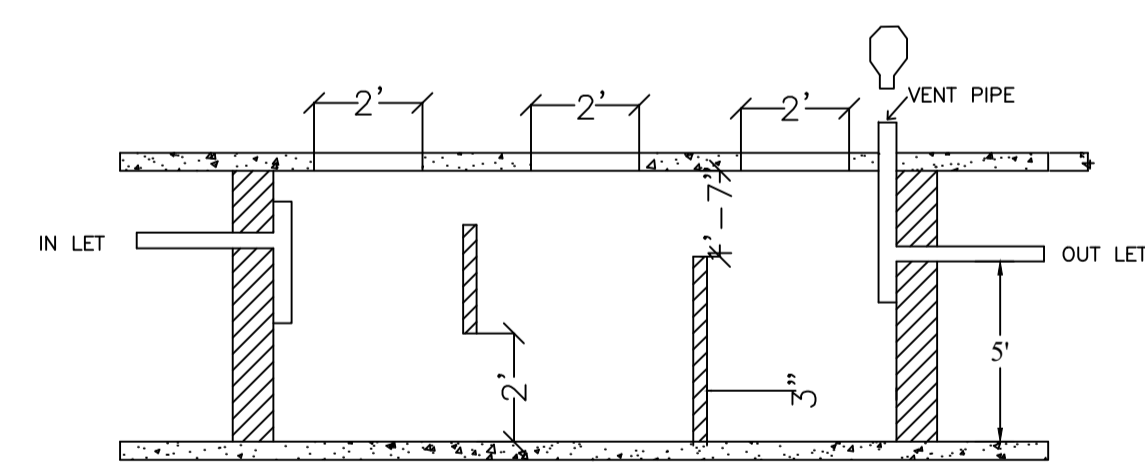

**SECTION ON-X,X**

**SCHEDULE OF DOOR:**

BUILDING NAME	NAME	LENGTH	HEIGHT	NOS
A (A)	D	0.76	2.10	03
A (A)	D	0.77	2.10	01
A (A)	D	0.91	2.10	02
A (A)	D	0.95	2.10	02
A (A)	D	0.97	2.10	01
A (A)	D	1.27	2.10	01
A (A)	ARCH	1.83	2.10	02

**SCHEDULE OF WINDOW/VENTILATION:**

BUILDING NAME	NAME	LENGTH	HEIGHT	NOS
A (A)	W	0.61	1.20	02
A (A)	W	1.22	1.20	02
A (A)	W	1.83	1.20	06

**Building :A (A)**

Floor Name	Total Built Up Area (Sq.mt.)	Proposed FAR Area (Sq.mt.)	Total FAR Area (Sq.mt.)	Total Consumed Additional FAR Area (Sq.mt.)	Tnmt (No.)
Ground Floor	58.08	58.08	58.08	58.08	01
First Floor	58.08	58.08	58.08	58.08	00
Terrace Floor	0.00	0.00	0.00	0.00	00
Total:	116.16	116.16	116.16	116.16	01
Total Number of Same Buildings:	1				
Total:	116.16	116.16	116.16	116.16	01

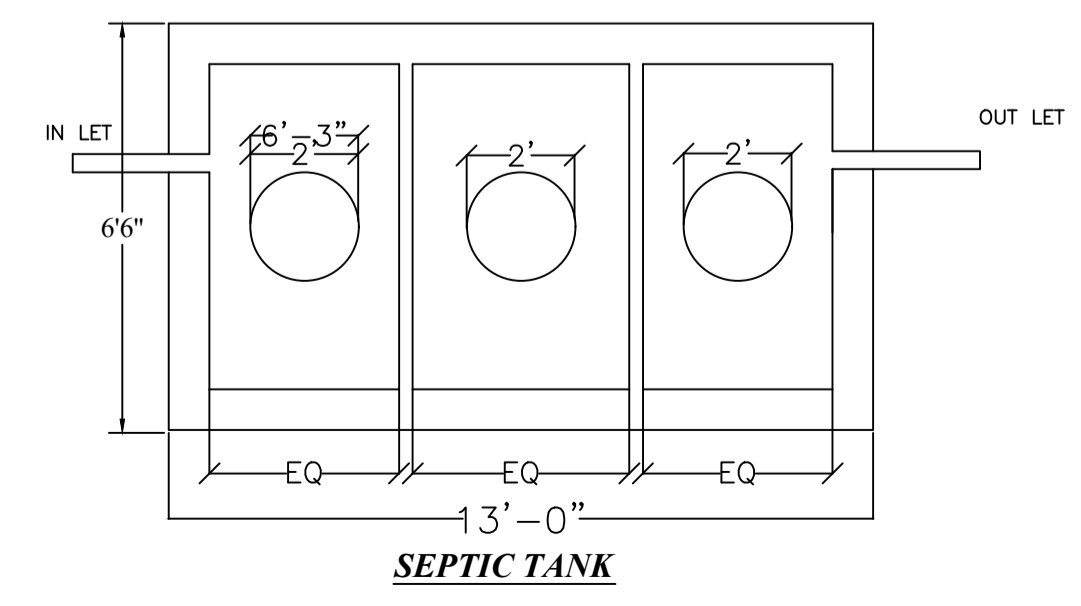

**SEPTIC TANK**

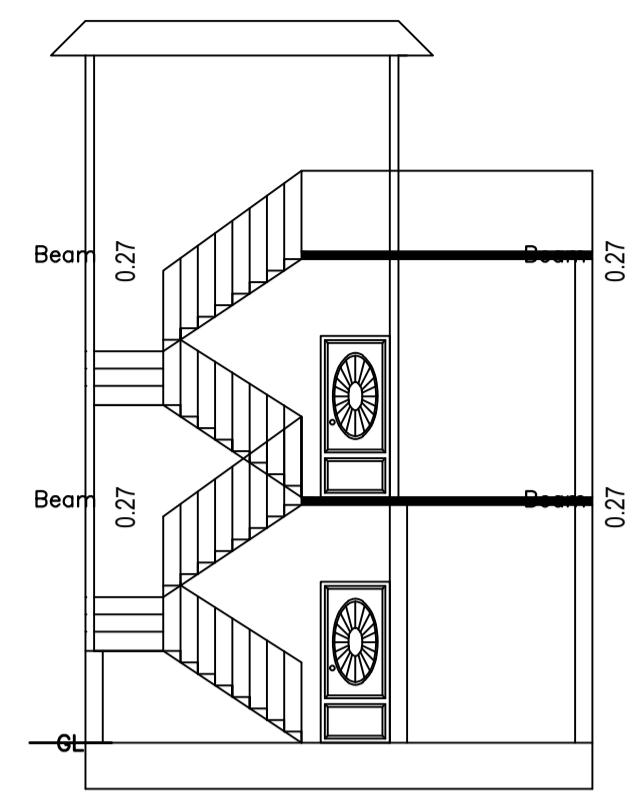

**SECTION ON XX**

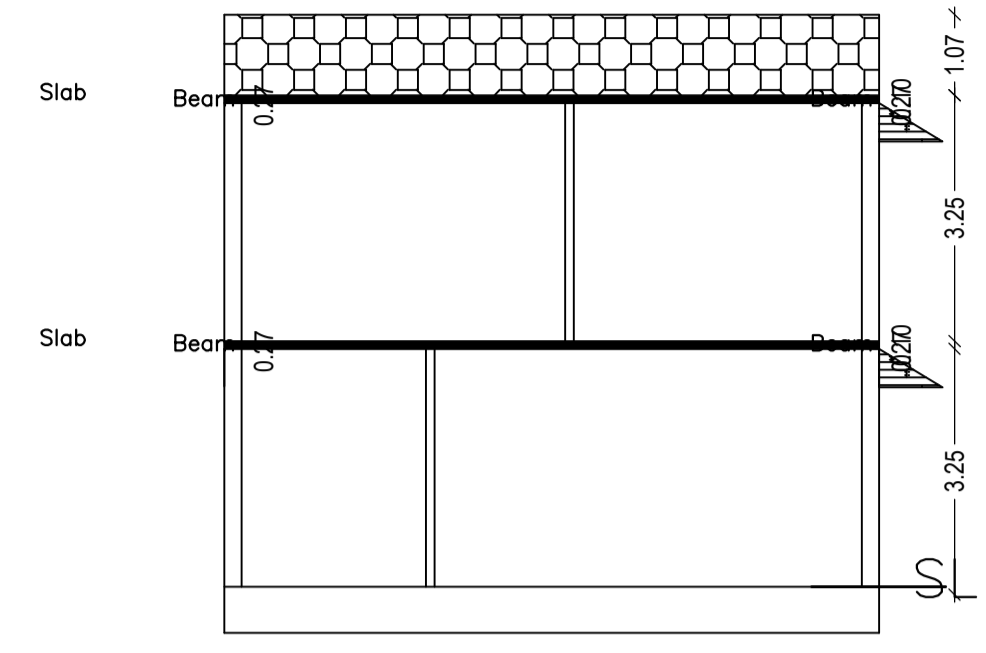

**SECTION ON YY**

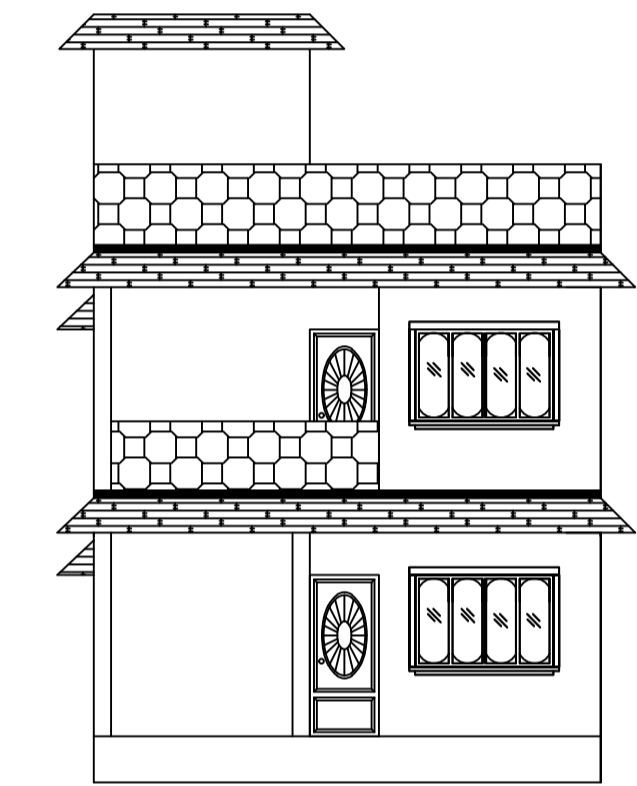

**FRONT ELEVATION**

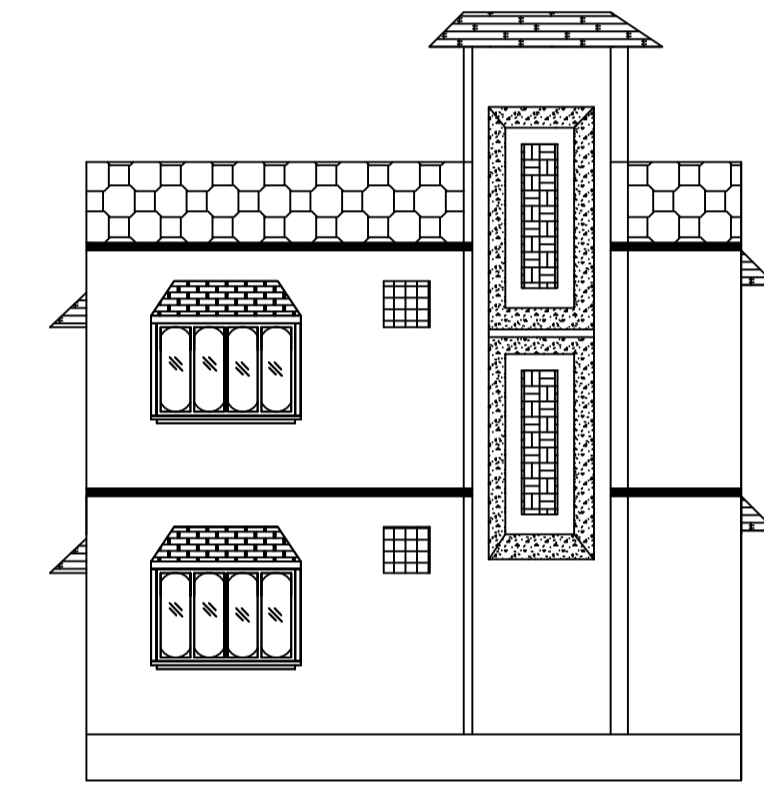

**LEFT SIDE ELEVATION**

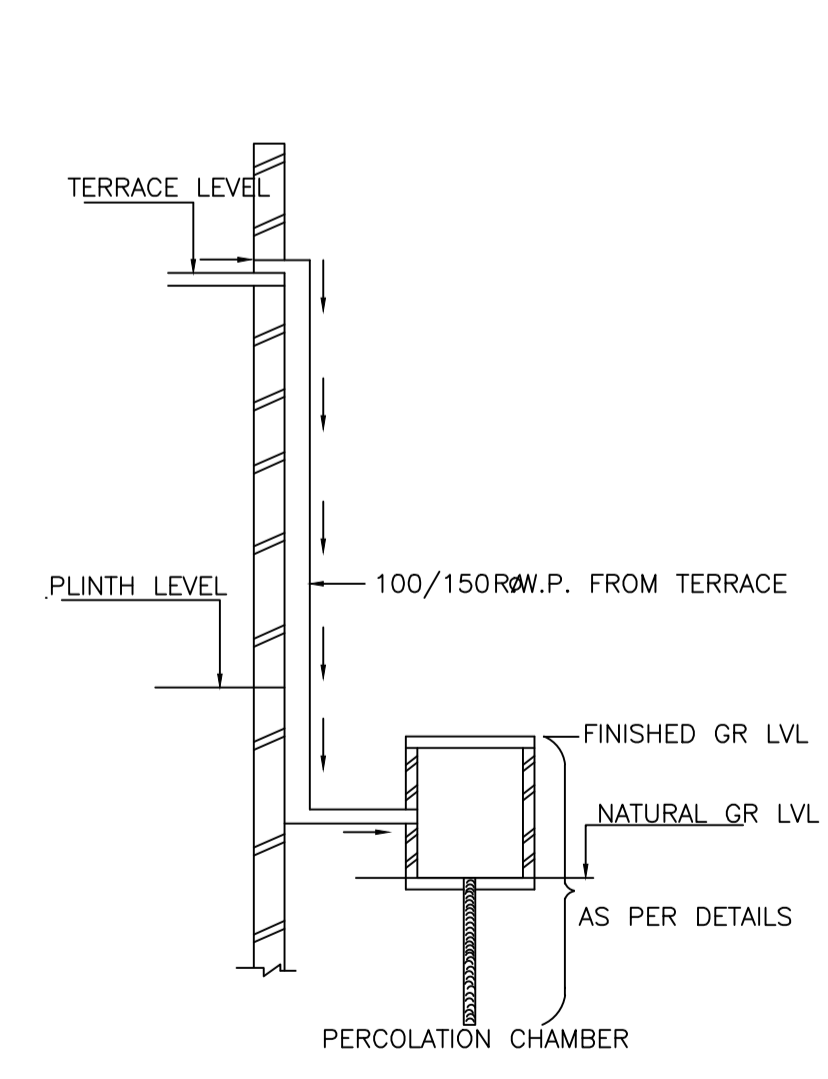

**ROOF TOP RAIN WATER COLLECTION SYSTEM**

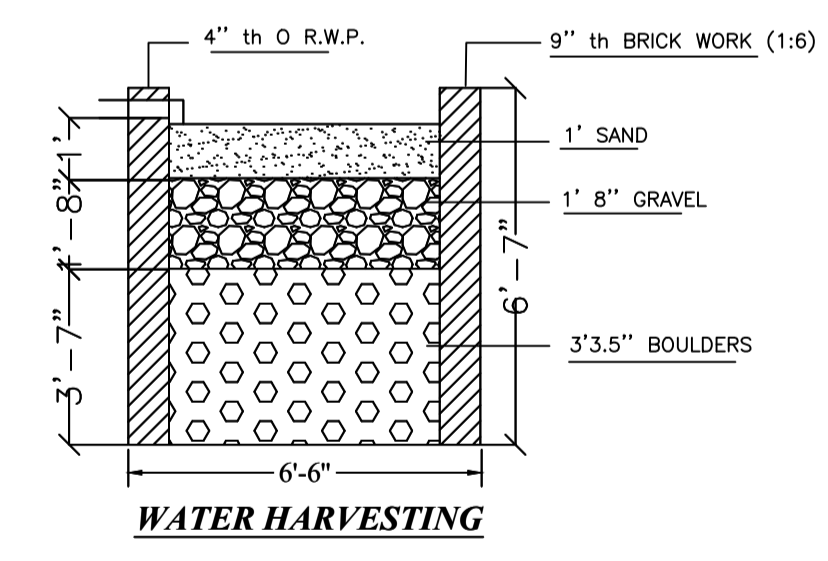

**WATER HARVESTING**

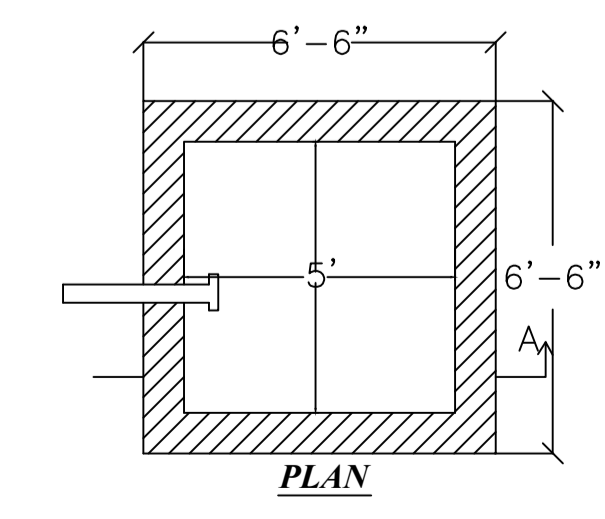

**PLAN**

**Proposal Basic Information**

Proposal File No.	MADA/BP/0132/2020
Owner Name	1 SRI SOMEN KUMAR PAUL 2 SMT. JOBA PAUL
Khata No	OLD- 74, NEW- 64
Plot No	OLD- 1454,1455,1456, NEW- 1633
Village Name	Nawadhi
Use	Residential
SubUse	Bungalow/ Dwelling / Non Apartment

**AREA STATEMENT MINERAL AREA DEVELOPMENT AUTHORITY**

AREA OF PLOT (Minimum)	(A)	SQ.MT.
AREA OF PLOT (Minimum)	(A)	92.75
NET AREA OF PLOT(Gross Plot Area - Deduction from Gross Plot area)	(A-Deductions)	92.75
Deduction for Balance Plot Area(from Gross Plot Area)		
Common Plot		7.37
Total		7.37
BALANCE AREA OF PLOT(Net Plot Area - Recreational/Amenity space)	(A-Deductions)	85.38
PLOT AREA FOR COVERAGE(Net Plot Area)	(A-Deductions)	92.75
Plot Area for FAR (Net Plot Area + Road Widening Area)	(A-Deductions)	92.75
COVERAGRE CHECK		
Permissible Coverage area ( 70.00 % )		64.92
Proposed Coverage Area ( 62.62 % )		58.08
Total Prop. Coverage Area ( 62.62 % )		58.08
Balance coverage area ( 7.37 % )		6.84
FAR CHECK		
Perm. FAR Area ( 1.80 )		166.95
Total Perm. FAR area		166.95
Residential FAR		116.16
Proposed FAR Area		116.16
Total Proposed FAR Area		116.16
Consumed FAR (Factor)		1.25
Balance FAR Area		50.79
BUILT UP AREA CHECK		
Total Proposed BuiltUp Area		116.16
ARCHITECT (Regd)	SANTOSH	
ENGINEER (Regd)		
SUPERVISOR (Regd)		
OWNER (Regd)	1 SRI SOMEN KUMAR PAUL 2 SMT. JOBA PAUL	
DEVELOPMENT AUTHORITY	LOCAL BODY	

**COLOR INDEX**

PLOT BOUNDARY	Black
ABUTTING ROAD	Green
PROPOSED CONSTRUCTION	Red
COMMON PLOT	Yellow
ROAD WIDENING AREA	Blue
EXISTING (To be retained)	Orange
EXISTING (To be demolished)	Purple

**Buildingwise Floor FAR Details**

Floor Name	Building Name A (A)		Total	
	Proposed Built Up Area (Sq.mt.)	Proposed FAR Area (Sq.mt.)	Total Proposed Built Up Area (Sq.mt.)	Total FAR Area (Sq.mt.)
Ground Floor	58.08	58.08	58.08	58.08
First Floor	58.08	58.08	58.08	58.08
Terrace Floor	0.00	0.00	0.00	0.00
Total:	116.16	116.16	116.16	116.16

**Building USE/SUBUSE Details**

Building Name	Building Use	Building SubUse	Building Structure
A (A)	Residential	Residential Bldg/Apartment	Non-Highrise

**FAR & Tenement Details (Table 4c-1)**

Building	No. of Same Bldg	Total Built Up Area (Sq.mt.)	Proposed FAR Area (Sq.mt.)	Total FAR Area (Sq.mt.)	Total Consumed Additional FAR Area (Sq.mt.)	Tnmt (No.)
A (A)	1	116.16	116.16	116.16	116.16	01
Grand Total:	1	116.16	116.16	116.16	116.16	01

**UnitBUA Table for Building :A (A)**

FLOOR	Name	UnitBUA Type	UnitBUA Area	Carpet Area	No. of Rooms	No. of Tenement
GROUND FLOOR PLAN	SPLIT A	FLAT	116.16	116.12	5	1
FIRST FLOOR PLAN	SPLIT A	FLAT	0.00	0.00	6	0
Total:	-	-	116.16	116.12	11	1

LTP NAME AND SIGNATURE	STRUCTURAL ENG'S NAME AND SIGNATURE	BUILDER NAME AND SIGNATURE	DIGITAL SIGNATURE
SANTOSH MADA/ENG/0022/2019			

Proposal Basic Information

Proposal File No.	MADA/BP/0132/2020
Owner Name	1 SRI SOMEN KUMAR PAUL 2 SMT. JOBA PAUL
Khata No	OLD- 74, NEW- 64
Plot No	OLD- 1454,1455,1456, NEW- 1633
Village Name	Nawadhi
Use	Residential
SubUse	Bungalow/ Dwelling / Non Apartment

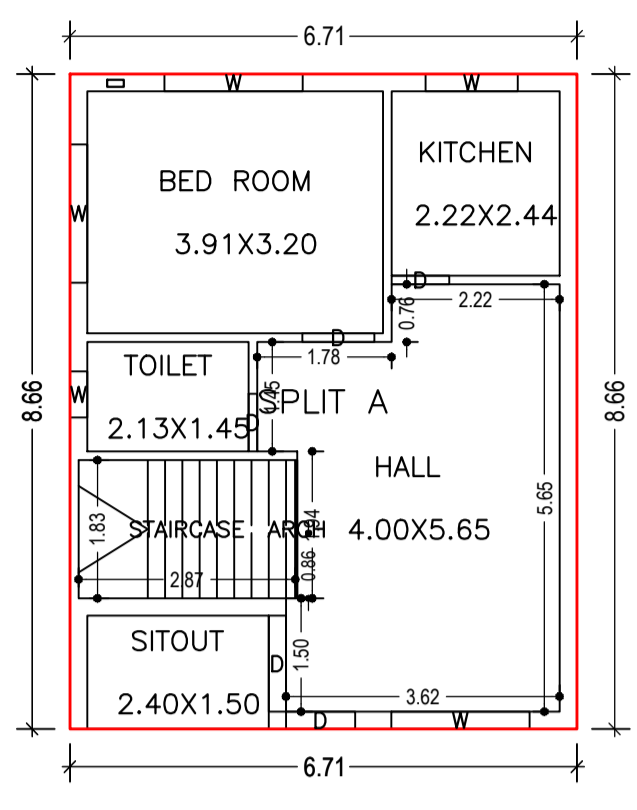

GROUND FLOOR PLAN  
(Proposed)  
(SCALE 1:100)

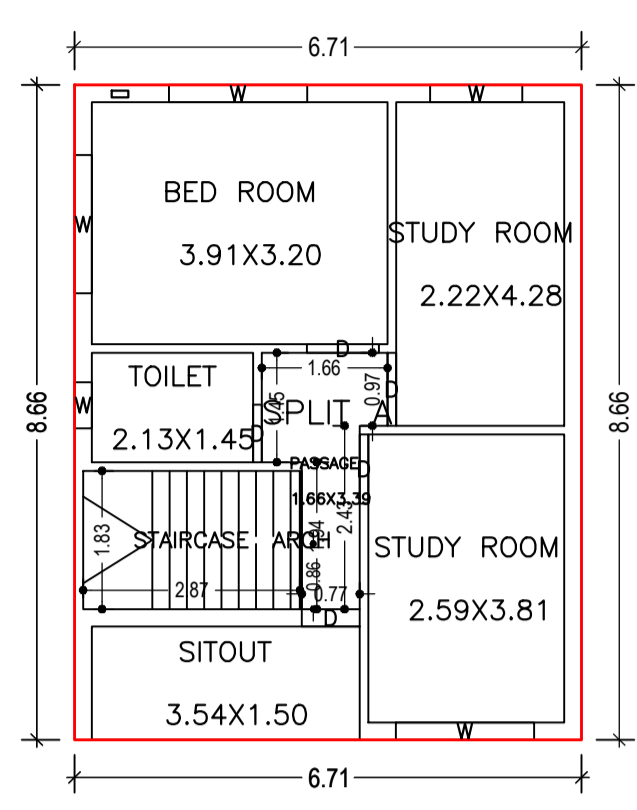

FIRST FLOOR PLAN  
(Proposed)  
(SCALE 1:100)

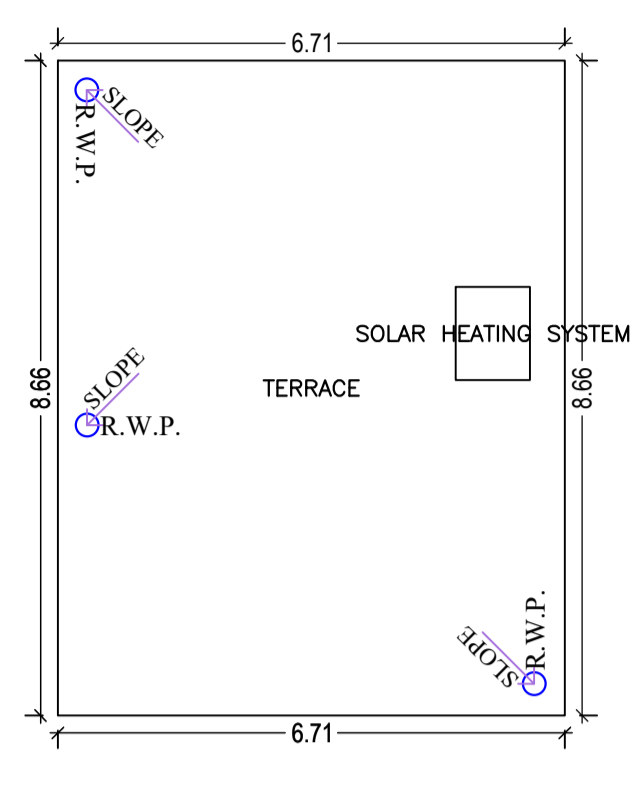

TERRACE FLOOR PLAN  
(SCALE 1:100)

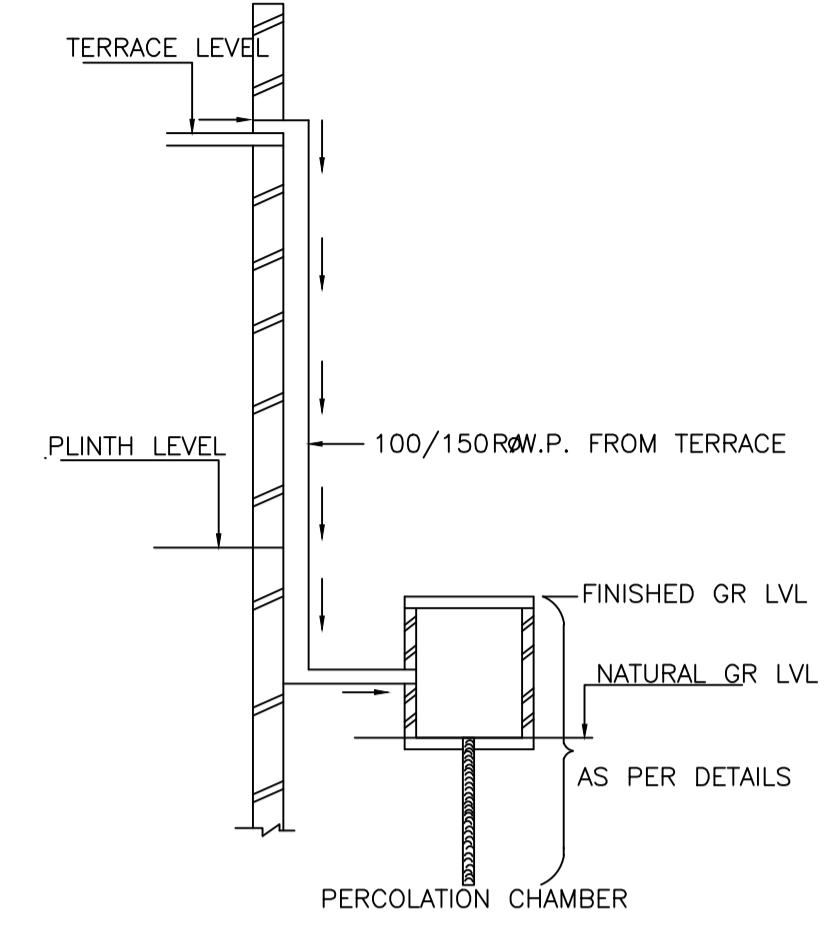

ROOF TOP RAIN WATER  
COLLECTION SYSTEM

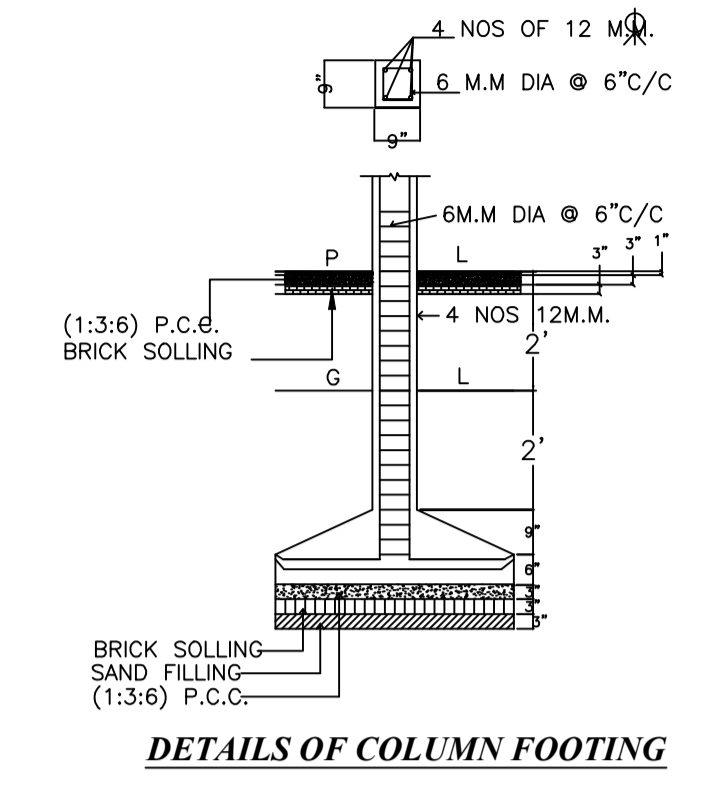

DETAILS OF COLUMN FOOTING

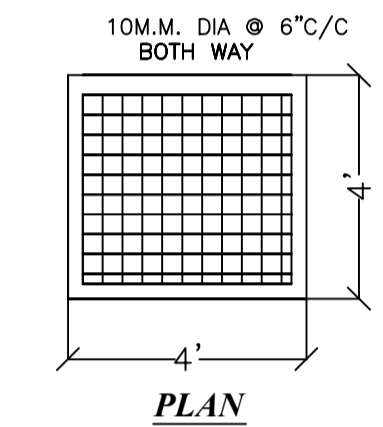

PLAN

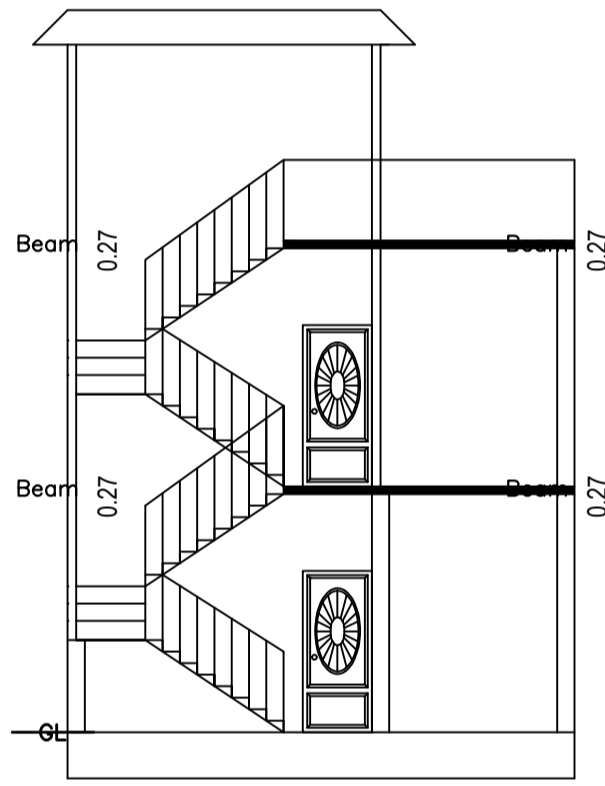

SECTION ON XX

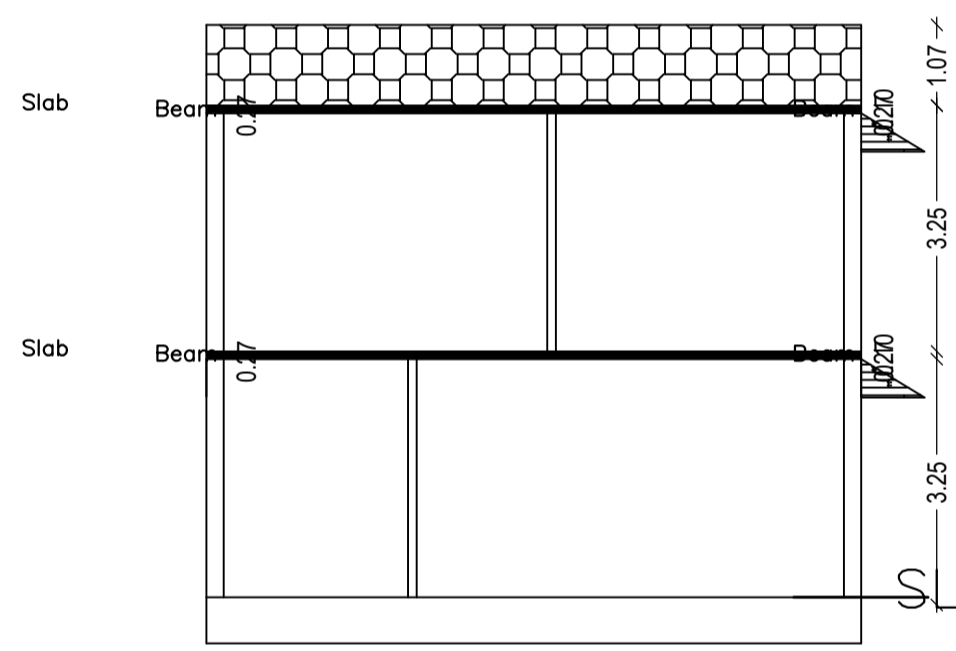

SECTION ON YY

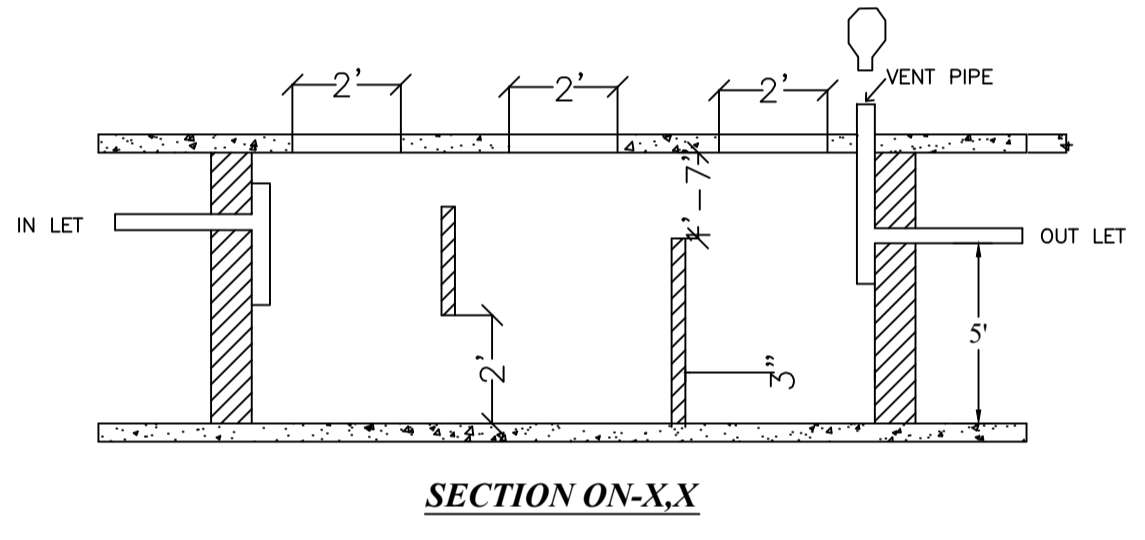

SECTION ON-X-X

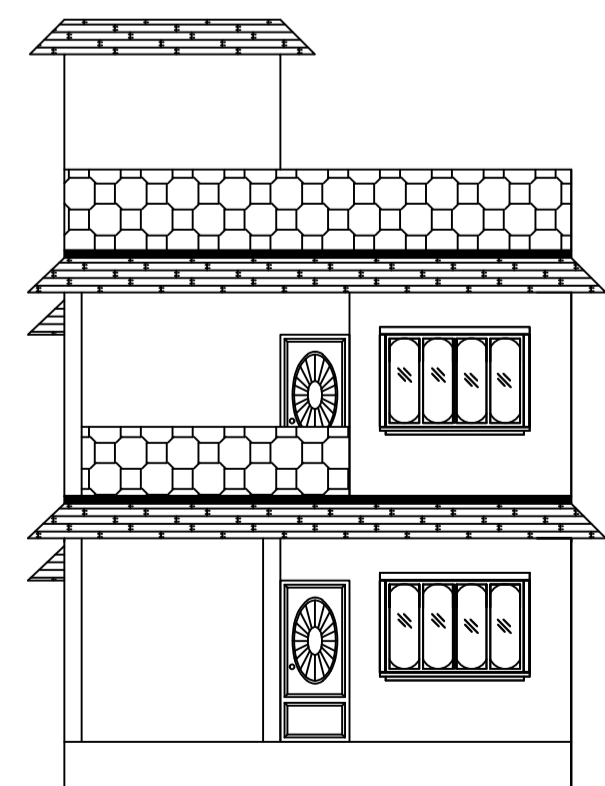

FRONT ELEVATION

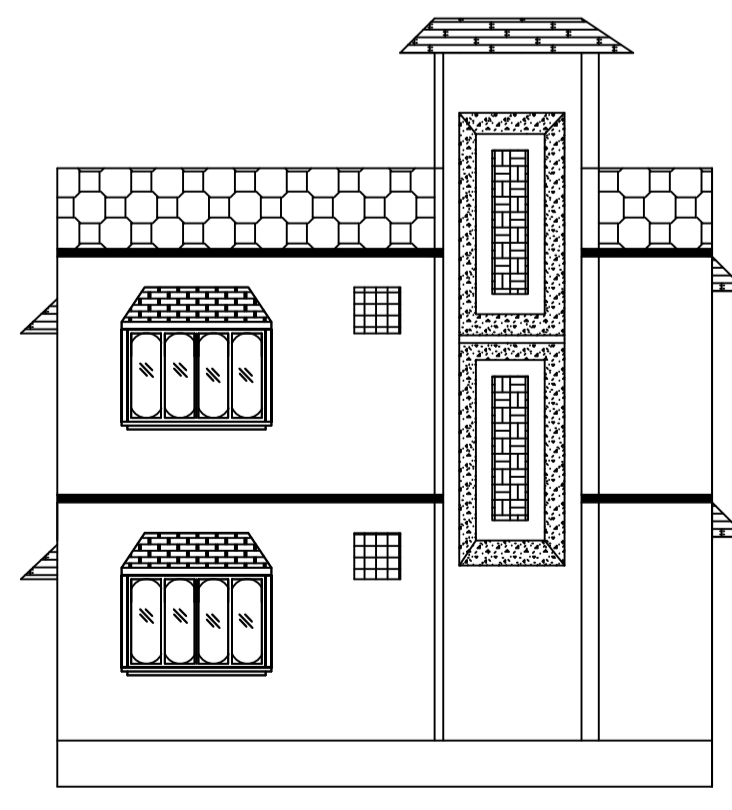

LEFT SIDE ELEVATION

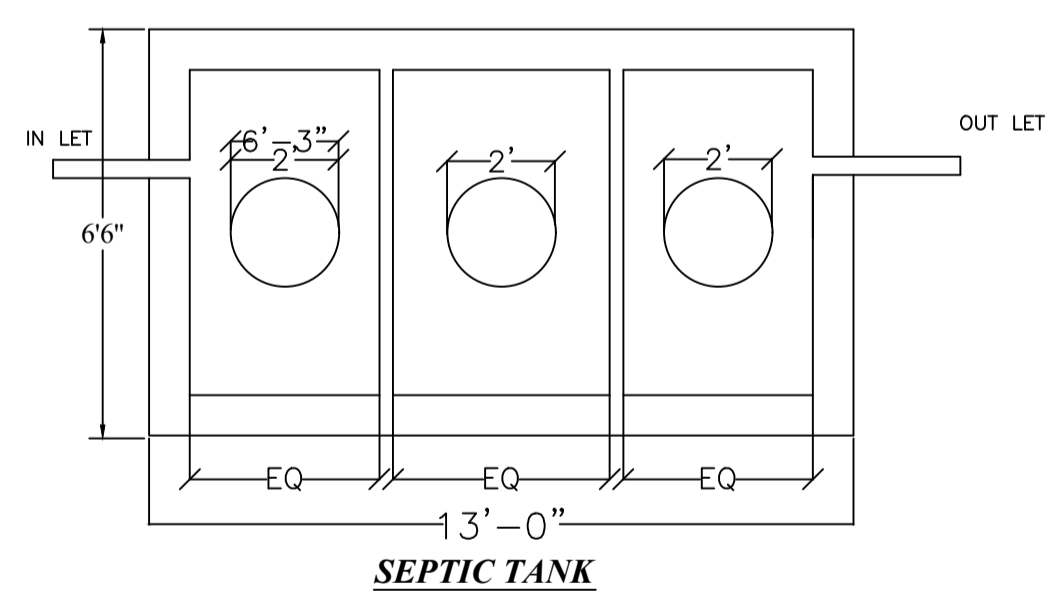

SEPTIC TANK

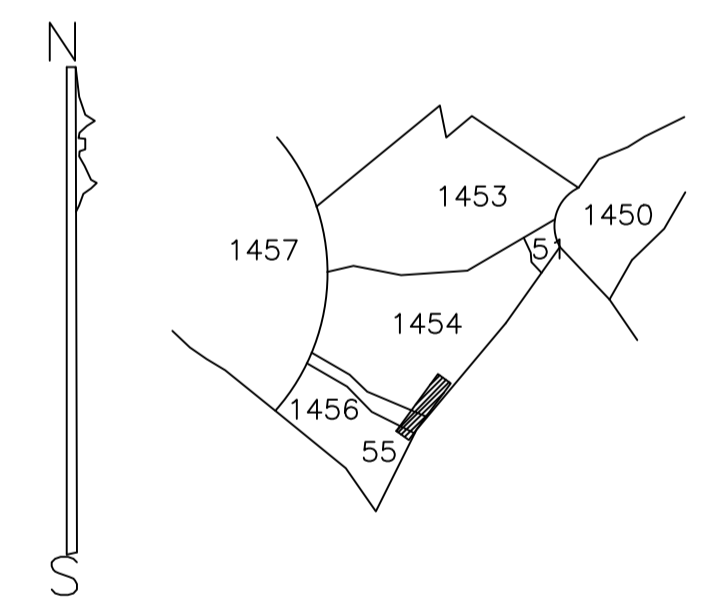

KEY PLAN  
1"=330'

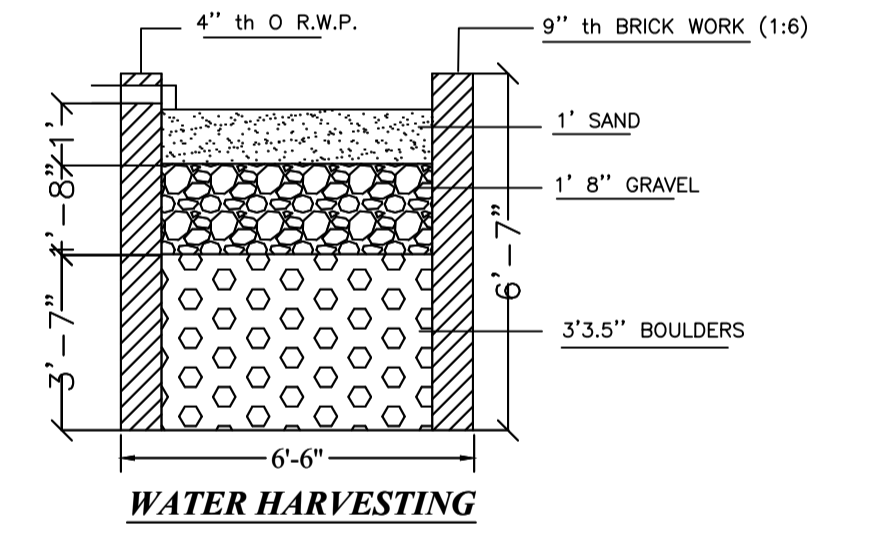

WATER HARVESTING

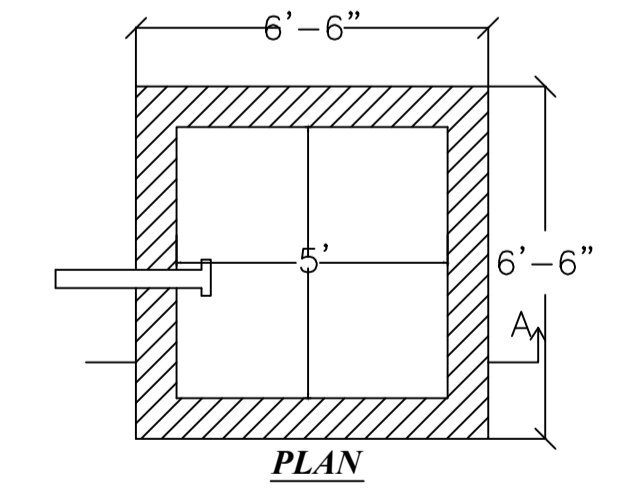

PLAN

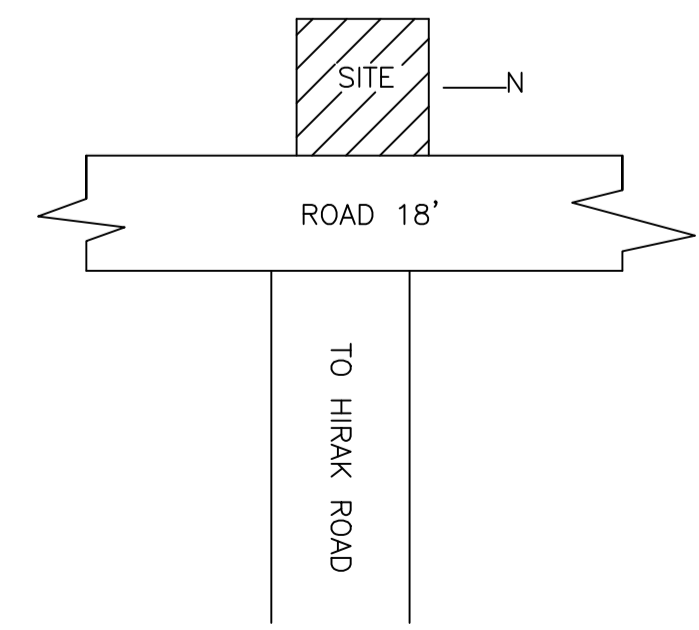

LOCATION PLAN

LTP NAME AND SIGNATURE	STRUCTURAL ENG'S NAME AND SIGNATURE	BUILDER NAME AND SIGNATURE	DIGITAL SIGNATURE
SANTOSH MADA/ENG/0022/2019			