

SRI SANJAY KR. PANDIT (H.U.F.)

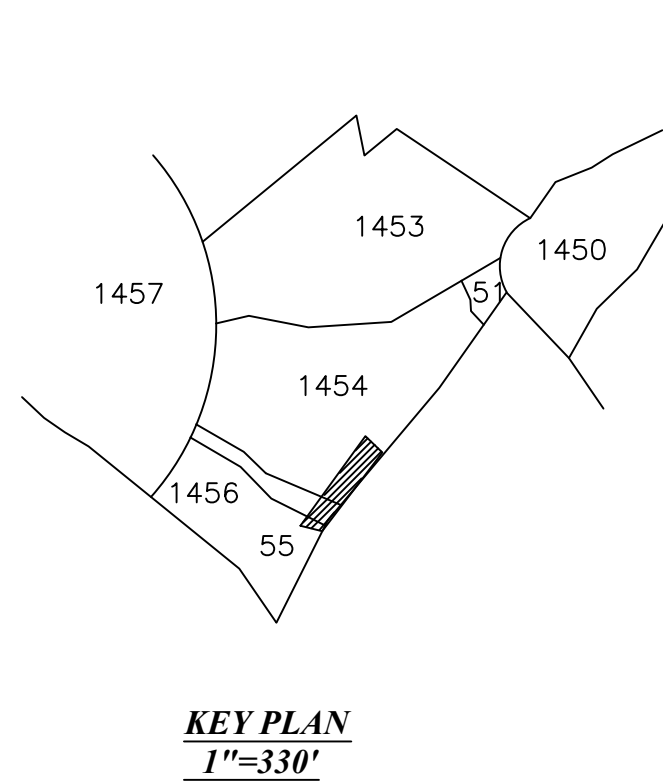
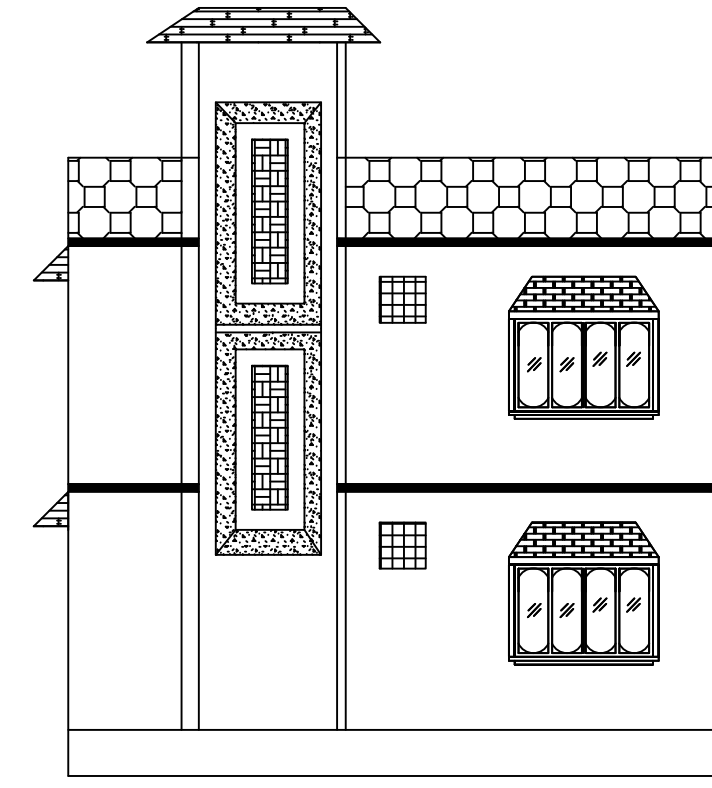
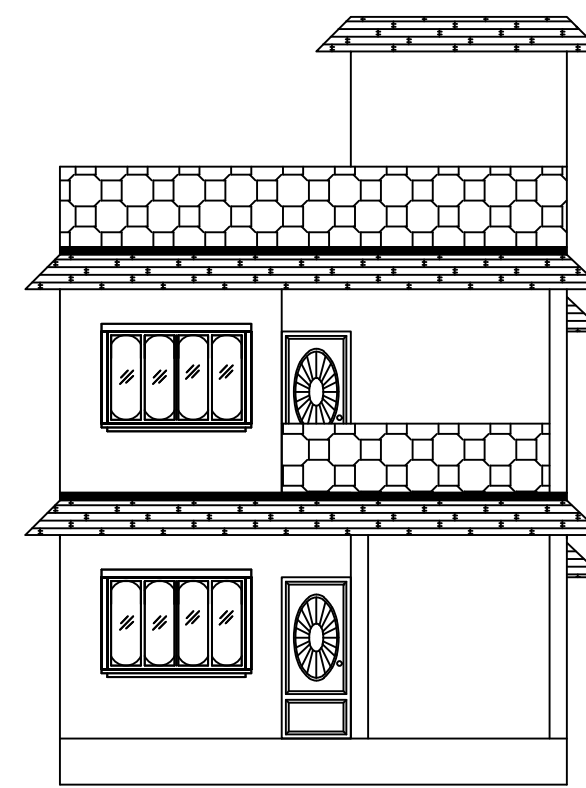
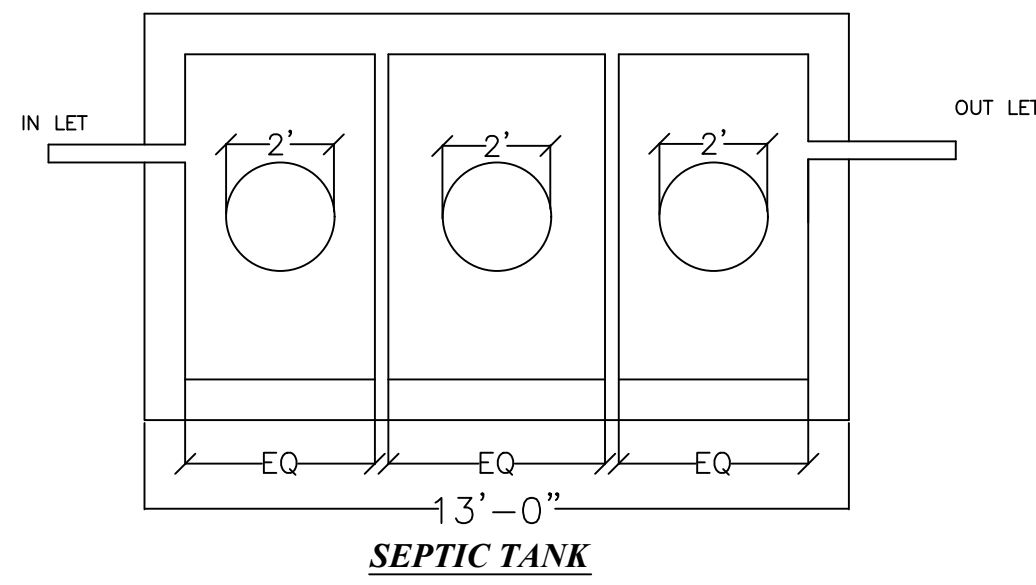
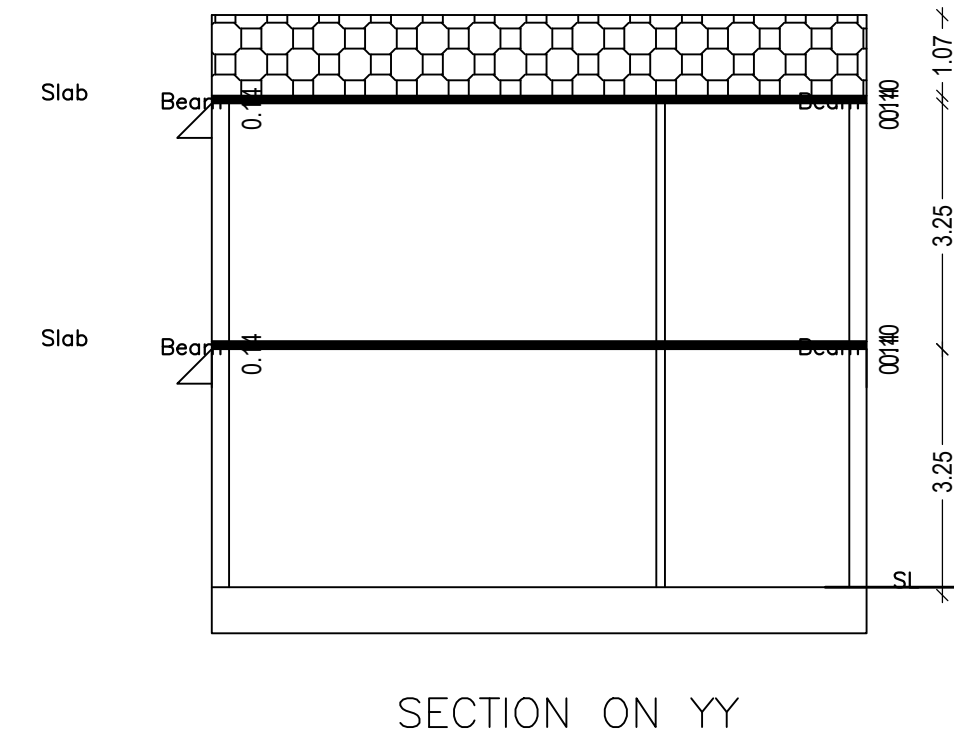
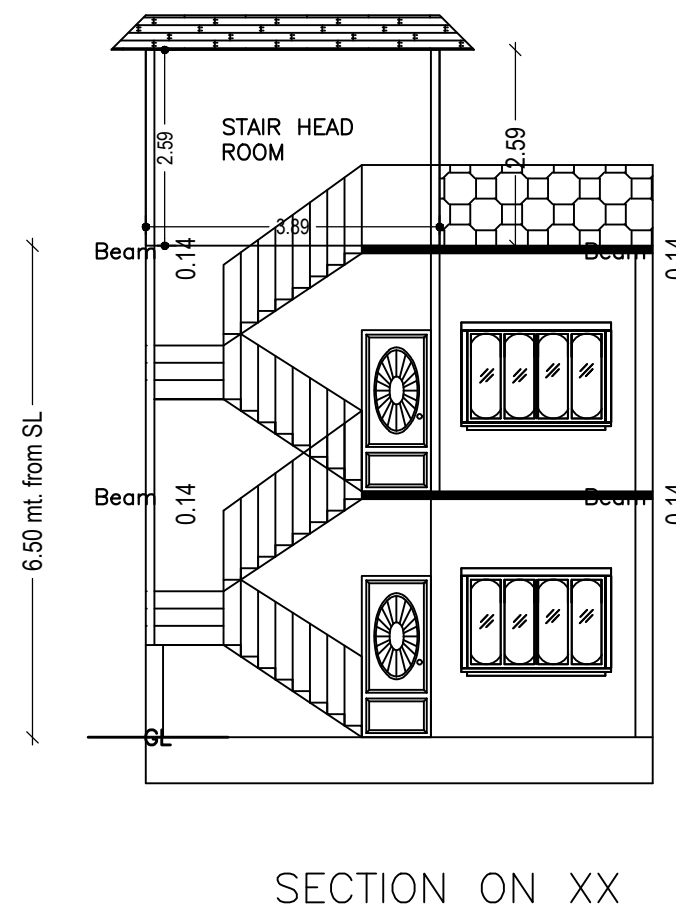
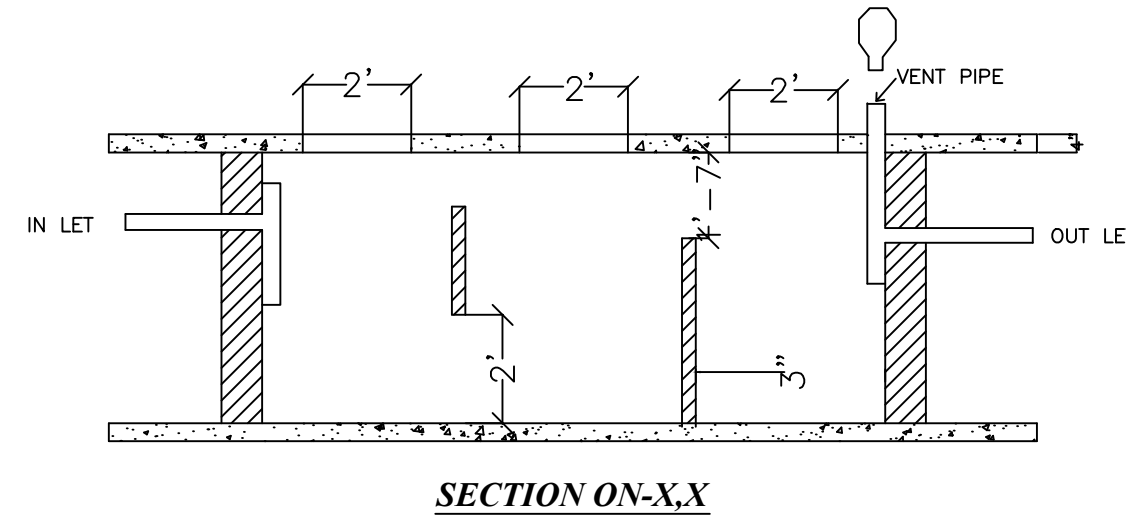

SCHEDULE OF DOOR:

BUILDING NAME	NAME	LENGTH	HEIGHT	NOS
A (A)	D	0.76	2.10	03
A (A)	D	0.91	2.10	03
A (A)	D	0.95	2.10	02
A (A)	D	0.97	2.10	01
A (A)	ARCH	1.27	2.10	02
A (A)	ARCH	2.40	2.10	01
A (A)	ARCH	3.54	2.10	01

SCHEDULE OF WINDOW/VENTILATION:

BUILDING NAME	NAME	LENGTH	HEIGHT	NOS
A (A)	W	0.61	1.20	02
A (A)	W	0.91	1.20	02
A (A)	W	1.22	1.20	02
A (A)	W	1.83	1.20	06

Building :A (A)

Floor Name	Total Built Up Area (Sq.mt.)	Proposed FAR Area (Sq.mt.)	Total FAR Area (Sq.mt.)	Total Consumed Additional FAR Area (Sq.mt.)	Tnmt (No.)
Ground Floor	58.08	58.08	58.08	58.08	01
First Floor	58.08	58.08	58.08	58.08	00
Terrace Floor	0.00	0.00	0.00	0.00	00
Total:	116.16	116.16	116.16	116.16	01
Total Number of Same Buildings	1				
Total:	116.16	116.16	116.16	116.16	01

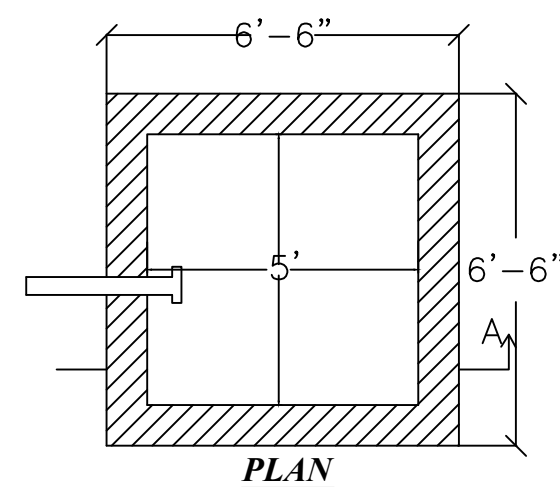
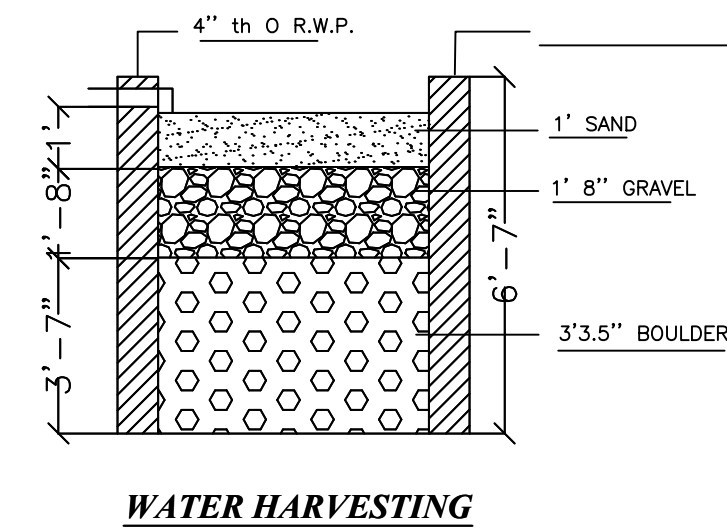
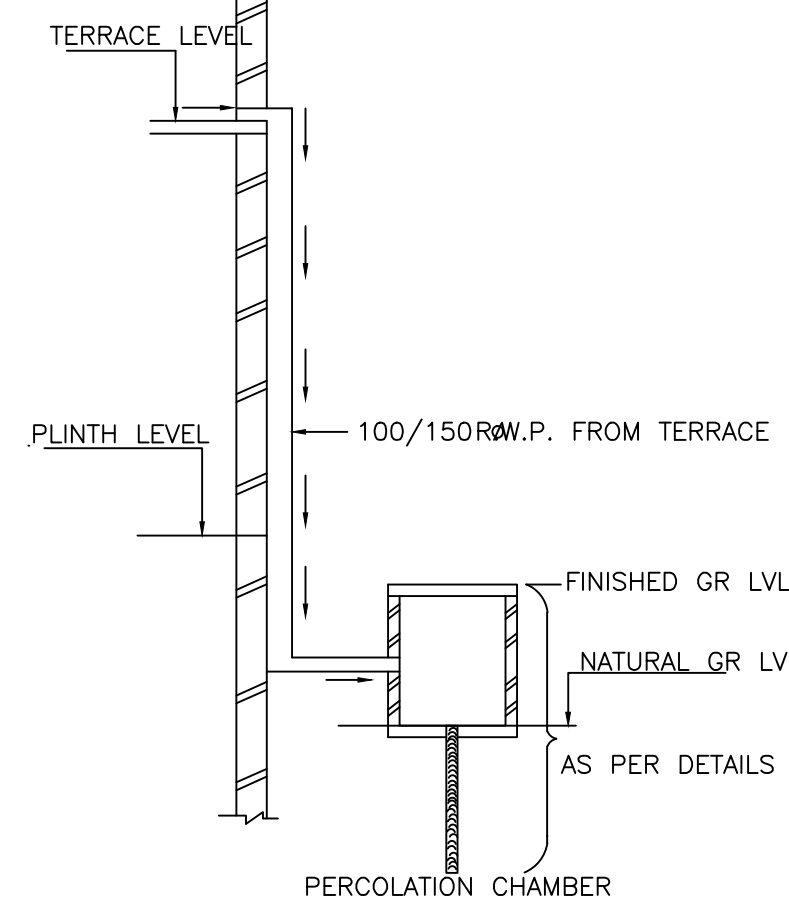
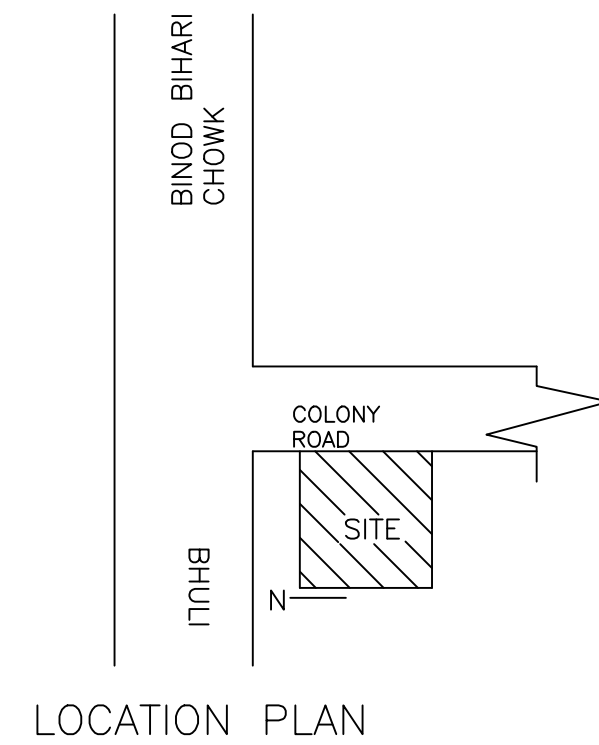

Proposal Basic Information	
Proposal File No.	MADA/BP/0130/2020
Owner Name	1 SRI BIMAN KUMAR PAUL 2 SMT. SNEHALATA PAUL
Khata No	OLD- 74, NEW- 64
Plot No	OLD- 1454,1455,1456, NEW- 1633
Village Name	Nawadh
Use	Residential
SubUse	Bungalow/ Dwelling / Non Apartment

AREA STATEMENT MINERAL AREA DEVELOPMENT AUTHORITY	VERSION NO.: 1.0.54
PROJECT DETAIL:	VERSION DATE: 16/10/2020
Region: JHARKHAND URBAN LOCAL BODIES	Plot Use: Residential
District: DHANBAD	Plot SubUse: Bungalow/ Dwelling / Non Apartment
Authority: MINERAL AREA DEVELOPMENT AUTHORITY	PlotNearby/ReligiousStructure: NA
Inward_No: MADA/BP/0130/2020	Plot/SubPlot No: OLD- 1454,1455,1456, NEW- 1633
Application Type: General Proposal	North: Plot No. - SRI GIRISH SINGH
Project Type: Building Permission	South: Plot No. - SRI SANJAY KR. PANDIT (H.U.F)
Nature of Development: New	East: Plot No. - SIMA PANDAL PALA
Location of Development Area: Old Area	West: Road Width - 5.50

AREA DETAILS:	SQ.MT.
AREA OF PLOT (Minimum)	(A) 92.75
NET AREA OF PLOT(Gross Plot Area - Deduction from Gross Plot area)	(A-Deductions) 92.75
Deduction for Balance Plot Area(from Gross Plot Area)	
Common Plot	5.81
Total	5.81
BALANCE AREA OF PLOT(Net Plot Area - Recreational/Amenity space)	(A-Deductions) 86.94
PLOT AREA FOR COVERAGE(Net Plot Area)	(A-Deductions) 92.75
Plot Area for FAR (Net Plot Area - Road/Widening Area)	(A-Deductions) 92.75

COVERAGE CHECK	
Permissible Coverage area (70.00 %)	64.92
Proposed Coverage Area (62.62 %)	58.08
Total Prop. Coverage Area (62.62 %)	58.08
Balance coverage area (7.37 %)	6.84

FAR CHECK	
Perm. FAR Area (1.80)	166.95
Total Perm. FAR area	166.95
Residential FAR	116.16
Proposed FAR Area	116.16
Total Proposed FAR Area	116.16
Consumed FAR (Factor)	1.25
Balance FAR Area	50.79

BUILT UP AREA CHECK	
Total Proposed BuiltUp Area	116.16

ARCHITECT (Regd)	SANTOSH
ENGINEER (Regd)	
SUPERVISOR (Regd)	
OWNER (Regd)	1 SRI BIMAN KUMAR PAUL 2 SMT. SNEHALATA PAUL
DEVELOPMENT AUTHORITY	LOCAL BODY

COLOR INDEX	
PLOT BOUNDARY	Black
ABUTTING ROAD	Red
PROPOSED CONSTRUCTION	Green
COMMON PLOT	Yellow
ROAD WIDENING AREA	Orange
EXISTING (To be retained)	Blue
EXISTING (To be demolished)	Light Blue

Floor Name	Building Name		Total	
	Proposed Built Up Area (Sq.mt.)	Proposed FAR Area (Sq.mt.)	Total Proposed Built Up Area (Sq.mt.)	Total FAR Area (Sq.mt.)
Ground Floor	58.08	58.08	58.08	58.08
First Floor	58.08	58.08	58.08	58.08
Terrace Floor	0.00	0.00	0.00	0.00
Total :	116.16	116.16	116.16	116.16

Building Name	Building Use	Building SubUse	Building Structure
A (A)	Residential	Residential Bldg/Apartment	Non-Highrise

Building	No. of Same Bldg	Total Built Up Area (Sq.mt.)	Proposed FAR Area (Sq.mt.)	Total FAR Area (Sq.mt.)	Total Consumed Additional FAR Area (Sq.mt.)	Tnmt (No.)
A (A)	1	116.16	116.16	116.16	116.16	01
Grand Total :	1	116.16	116.16	116.16	116.16	01

UnitBUA Table for Building :A (A)						
FLOOR	Name	UnitBUA Type	UnitBUA Area	Carpet Area	No. of Rooms	No. of Tenement
GROUND FLOOR PLAN	SPLIT A	FLAT	116.16	116.11	5	1
FIRST FLOOR PLAN	SPLIT A	FLAT	0.00	0.00	6	0
Total:	-	-	116.16	116.11	11	1

LTP NAME AND SIGNATURE	STRUCTURAL ENG'S NAME AND SIGNATURE	BUILDER NAME AND SIGNATURE	DIGITAL SIGNATURE
SANTOSH MADA/ENG/0022/2019			

Proposal Basic Information	
Proposal File No.	MADA/BP/0130/2020
Owner Name	1 SRI BIMAN KUMAR PAUL 2 SMT. SNEHALATA PAUL
Khata No	OLD- 74, NEW- 64
Plot No	OLD- 1454,1455,1456, NEW- 1633
Village Name	Nawadh
Use	Residential
SubUse	Bungalow/ Dwelling / Non Apartment

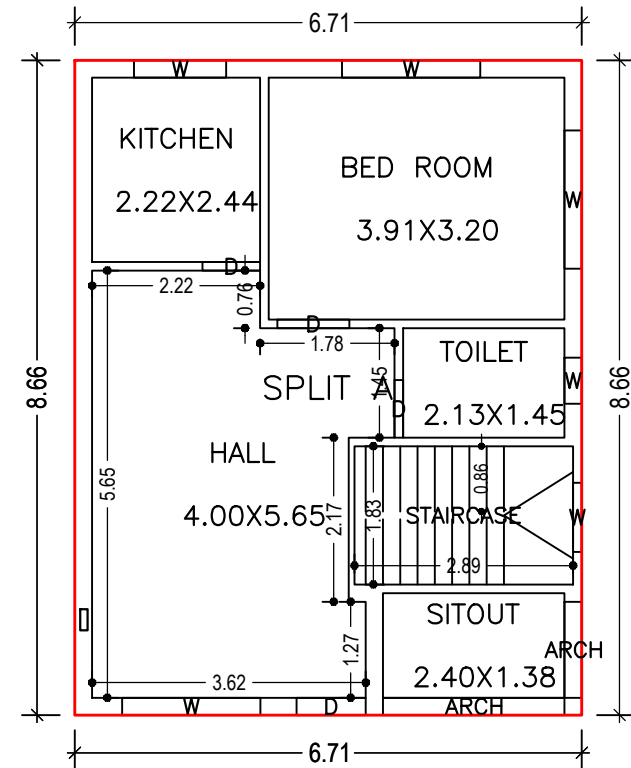

GROUND FLOOR PLAN
(Proposed)
(SCALE 1:100)

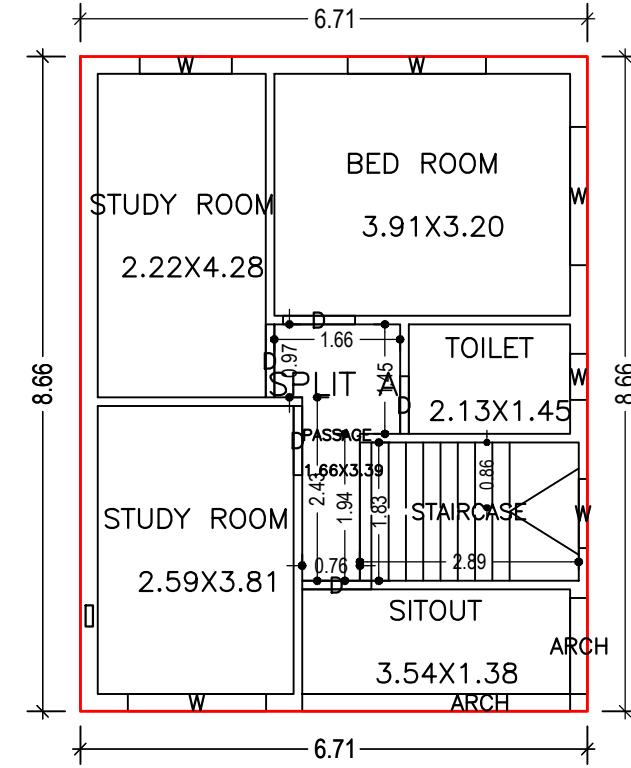

FIRST FLOOR PLAN
(Proposed)
(SCALE 1:100)

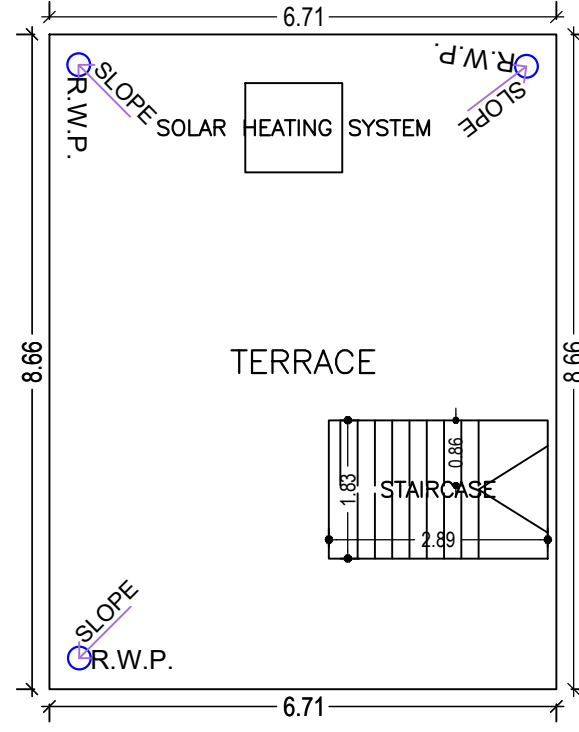

TERRACE FLOOR PLAN
(SCALE 1:100)

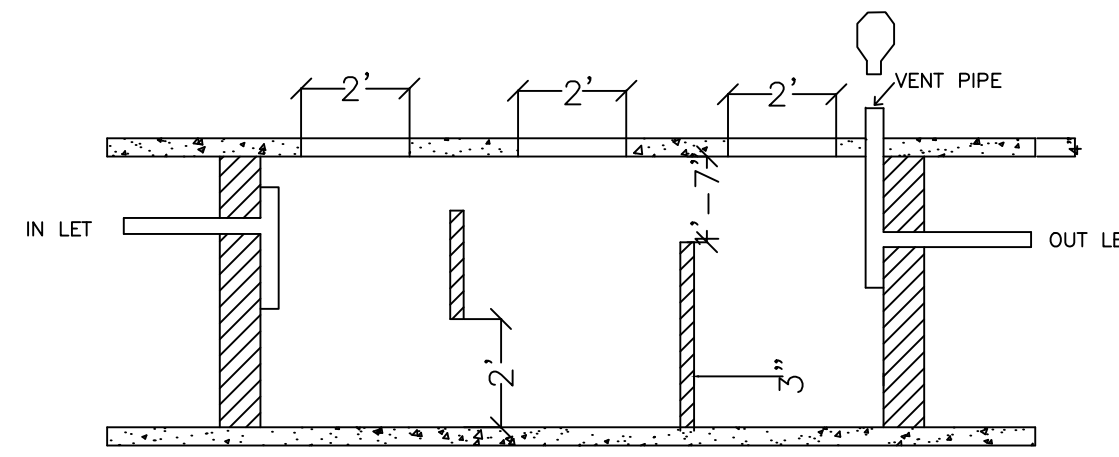

SECTION ON-X-X

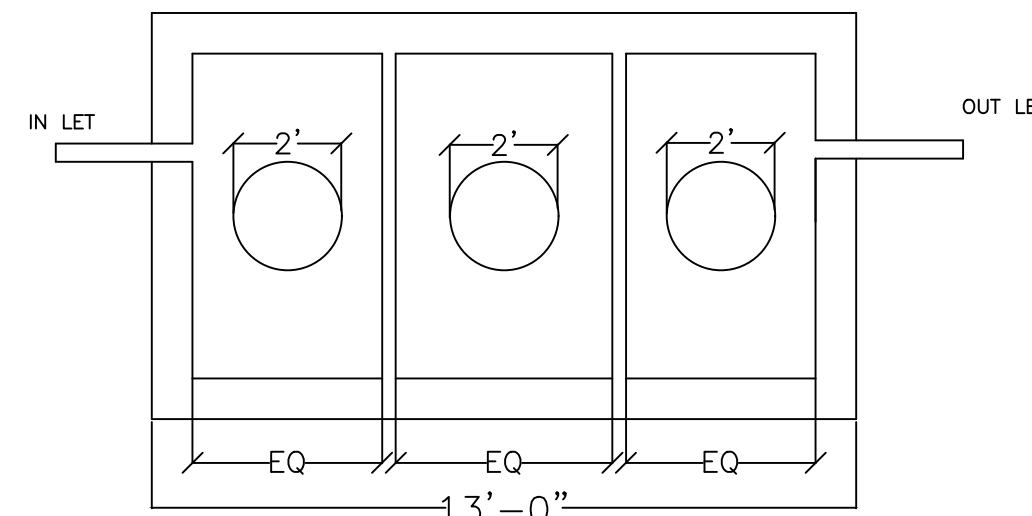

SEPTIC TANK

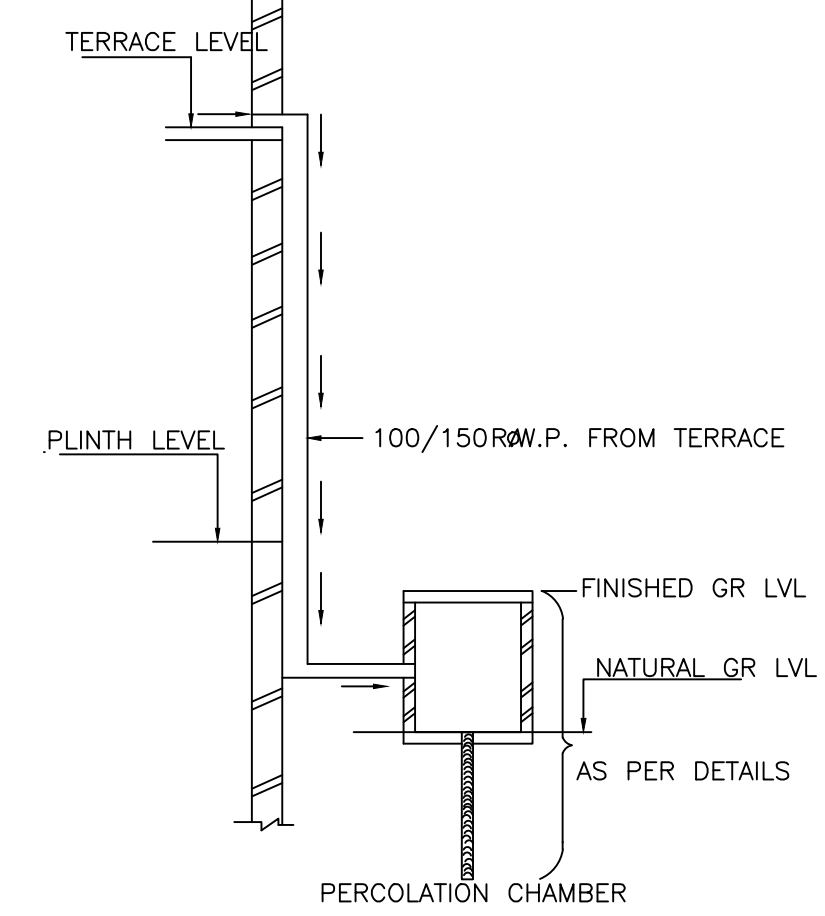

ROOF TOP RAIN WATER
COLLECTION SYSTEM

SIMA PANDAL PALA

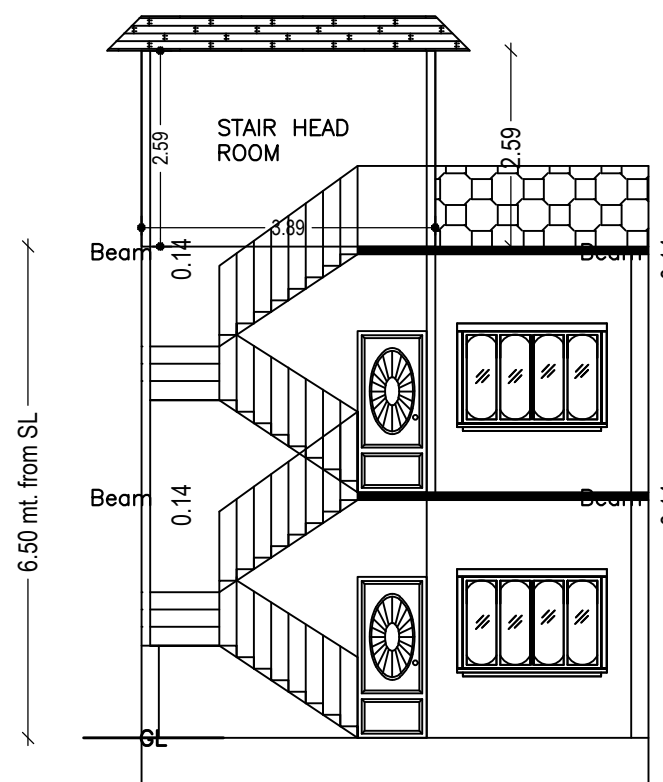

SECTION ON XX

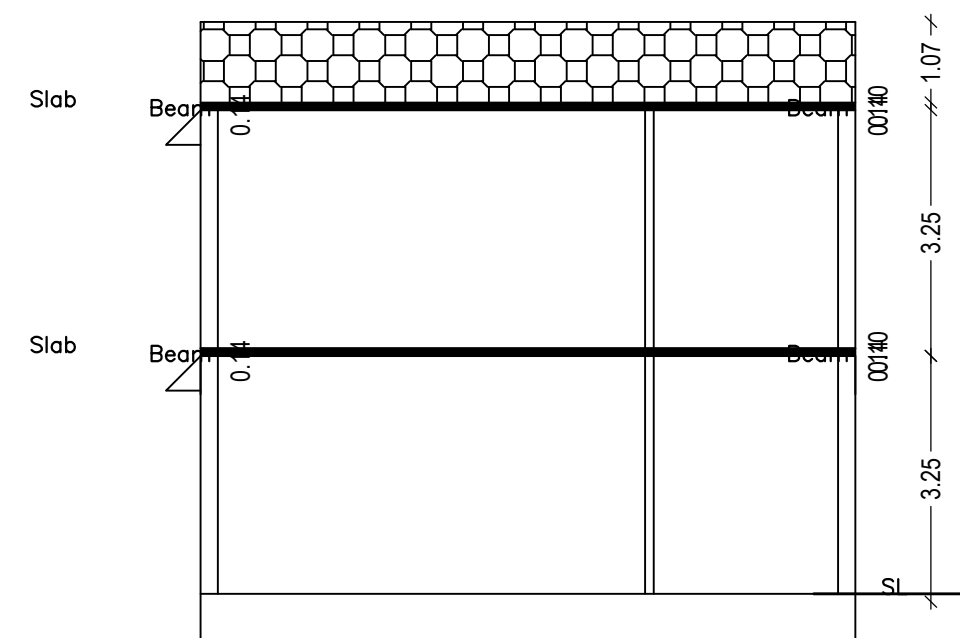

SECTION ON YY

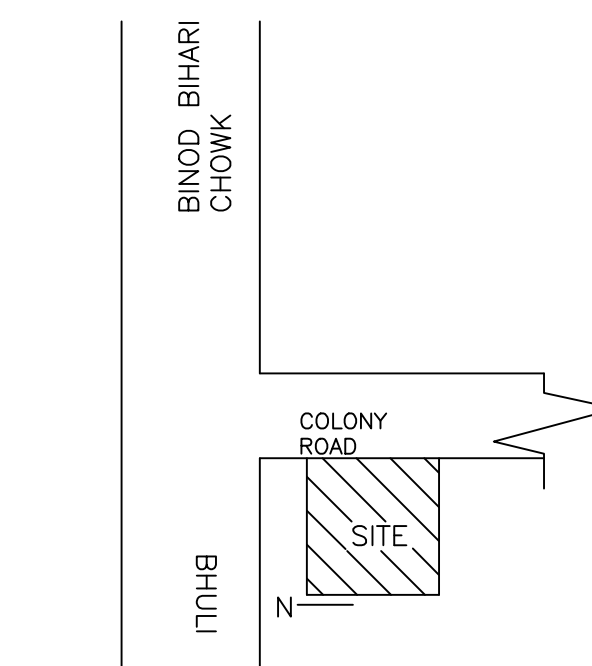

LOCATION PLAN

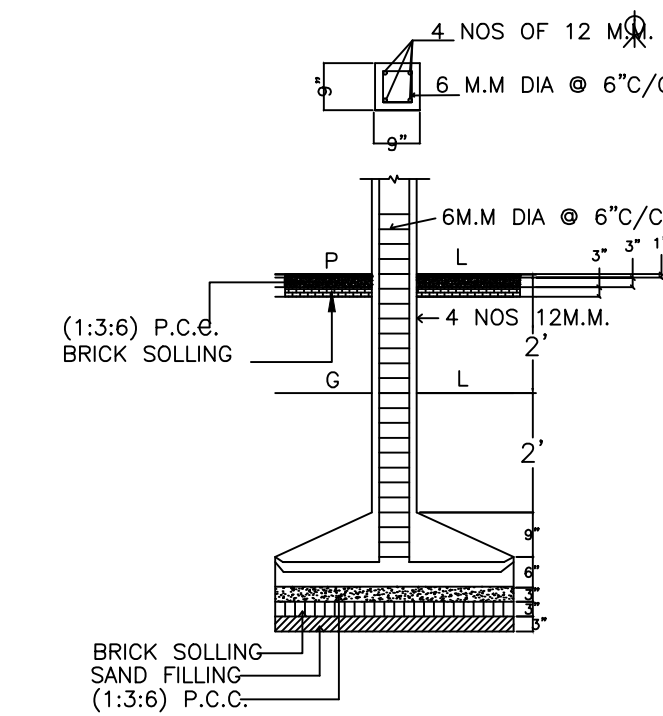

DETAILS OF COLUMN FOOTING

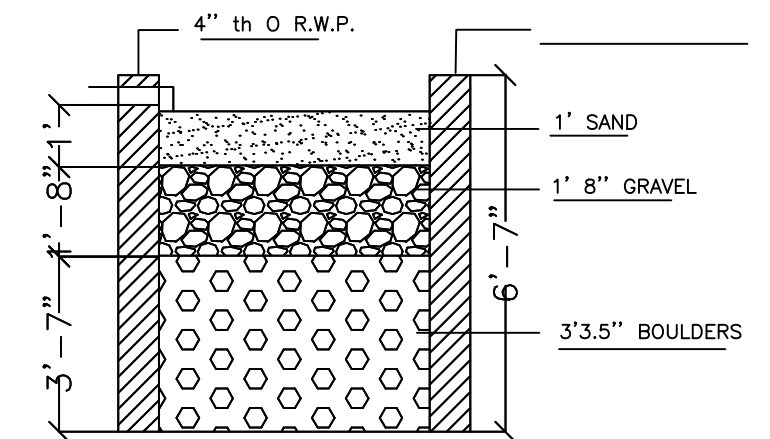

WATER HARVESTING

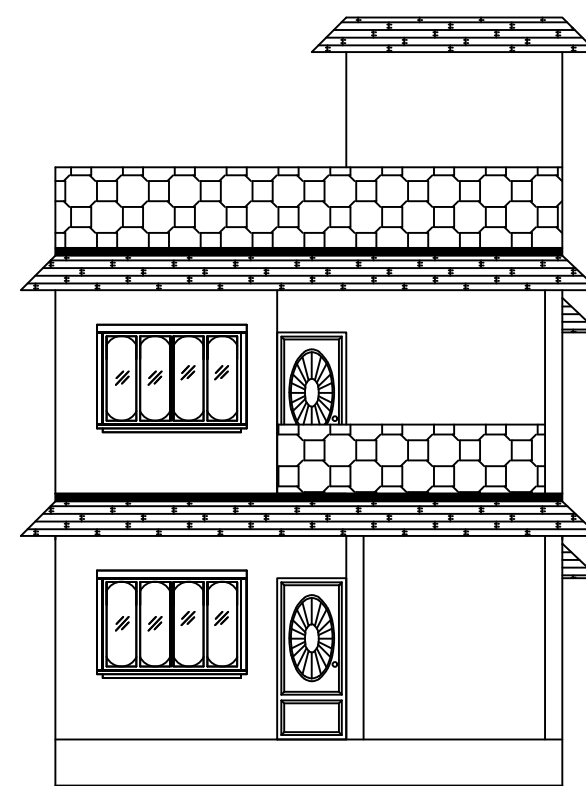

FRONT ELEVATION

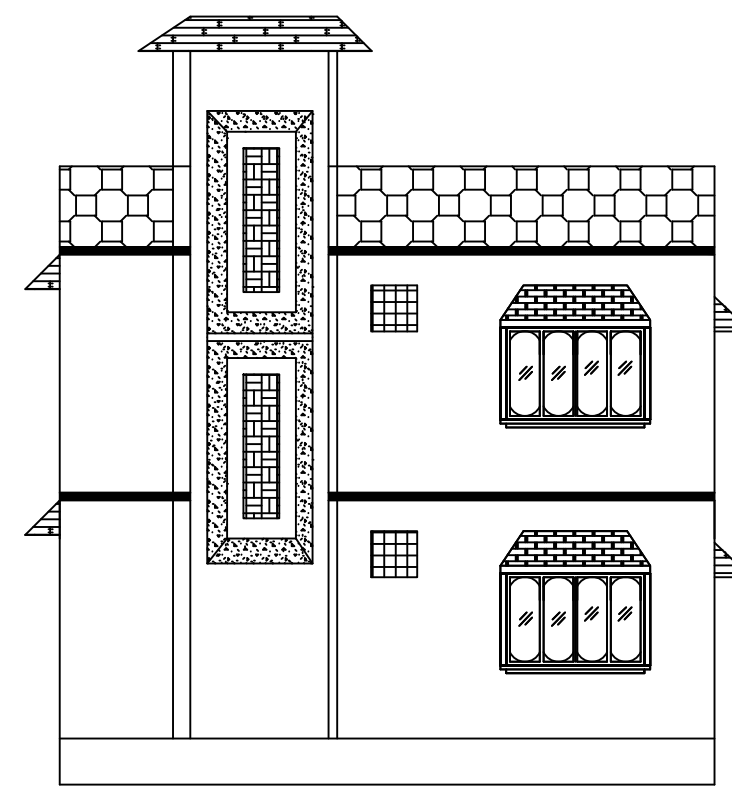

RIGHT SIDE ELEVATION

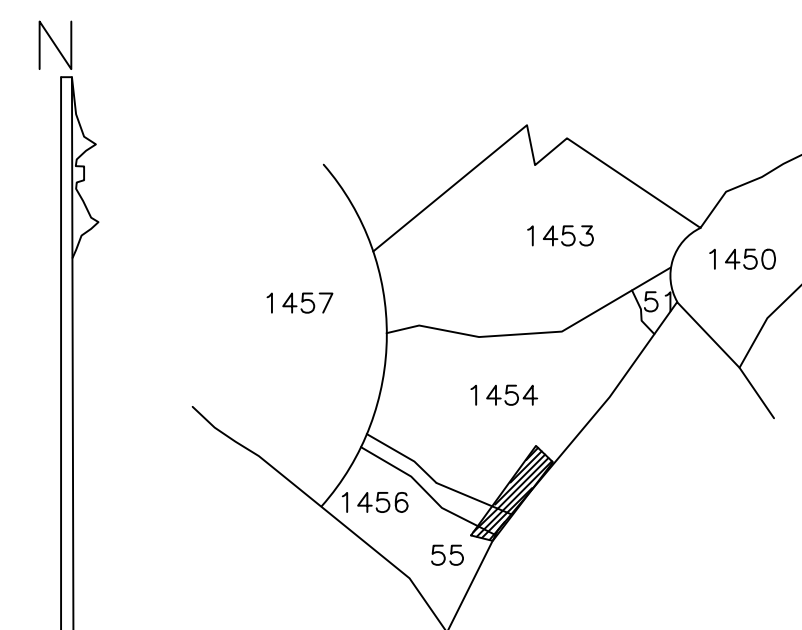

KEY PLAN
1"=330'

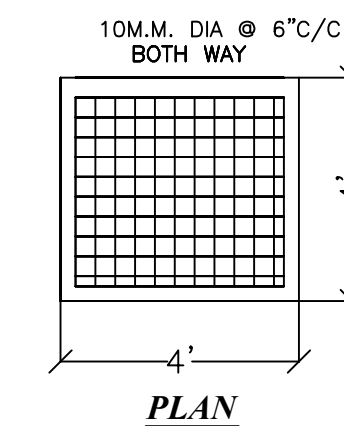

PLAN

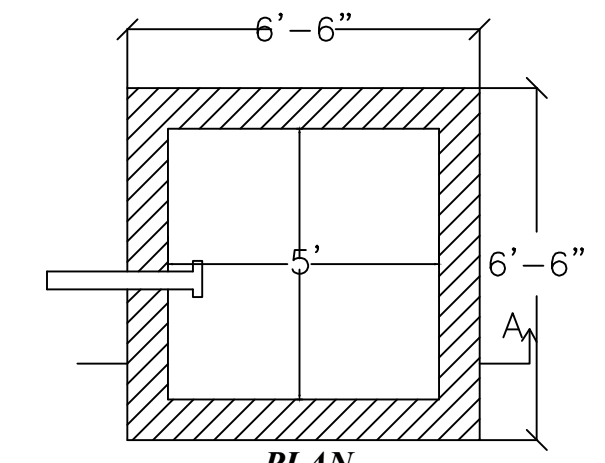

PLAN

LTP NAME AND SIGNATURE	STRUCTURAL ENG'S NAME AND SIGNATURE	BUILDER NAME AND SIGNATURE	DIGITAL SIGNATURE
SANTOSH MADA/ENG/0022/2019			