

Proposal Basic Information

Proposal File No.	MADA/BP/0124/2020
Owner Name	SMT ANANTI DEVI
Khata No	OLD 20,42, NEW =40, 70
Plot No	(OLD 474, 476,484) (NEW 475,476,1437)
Village Name	Jialgora
Use	Residential
SubUse	Bungalow/ Dwelling / Non Apartment

AREA STATEMENT MINERAL AREA DEVELOPMENT AUTHORITY	VERSION NO.: 1.0.54 VERSION DATE: 16/10/2020
PROJECT DETAIL:	
Region: JHARKHAND URBAN LOCAL BODIES	Plot Use: Residential
District: DHANBAD	Plot SubUse: Bungalow/ Dwelling / Non Apartment
Authority: MINERAL AREA DEVELOPMENT AUTHORITY	PlotNearby/ReligiousStructure: NA
Inward No: MADA/BP/0124/2020	Plot/SubPlot No: (OLD 474, 476,484) (NEW 475,476,1437)
Application Type: General Proposal	North: Plot No. - LOT NO - 08
Project Type: Building Permission	South: Plot No. - LOT NO - 06
Nature of Development: New	East: Road Width - 5.18
Location of Development Area: Old Area	West: Plot No. - PART OF THIS PLOT
AREA DETAILS:	
AREA OF PLOT (Minimum)	(A) 185.70 SQ.MT.
NET AREA OF PLOT(Gross Plot Area - Deduction from Gross Plot area)	(A-Deductions) 185.70
Deduction for Balance Plot Area(from Gross Plot Area)	
Common Plot	9.79
Total	9.79
BALANCE AREA OF PLOT(Net Plot Area - Recreational/Amenity space)	(A-Deductions) 175.91
PLOT AREA FOR COVERAGE(Net Plot Area)	(A-Deductions) 185.70
Plot Area for FAR (Net Plot Area + Road Widening Area)	(A-Deductions) 185.70
COVERAGE CHECK	
Permissible Coverage area (70.00 %)	129.99
Proposed Coverage Area (48.54 %)	90.14
Total Prop. Coverage Area (48.54 %)	90.14
Balance coverage area (21.46 %)	39.85
FAR CHECK	
Perm. FAR Area (1.80)	334.26
Total Perm. FAR area	334.26
Residential FAR	180.27
Proposed FAR Area	180.27
Total Proposed FAR Area	180.27
Consumed FAR (Factor)	0.97
Balance FAR Area	153.99
BUILT UP AREA CHECK	
Total Proposed BuiltUp Area	180.28
ARCHITECT (Regd)	ASHOK KUMAR
ENGINEER (Regd)	
SUPERVISOR (Regd)	
OWNER (Regd)	SMT ANANTI DEVI
DEVELOPMENT AUTHORITY LOCAL BODY	

COLOR INDEX

PLOT BOUNDARY	Black
ABUTTING ROAD	Green
PROPOSED CONSTRUCTION	Red
COMMON PLOT	Yellow
ROAD WIDENING AREA	Orange
EXISTING (To be retained)	Blue
EXISTING (To be demolished)	Light Blue

Buildingwise Floor FAR Details

Floor Name	Building Name A (RESIDENTIAL)		Total	
	Proposed Built Up Area (Sq.mt.)	Proposed FAR Area (Sq.mt.)	Total Proposed Built Up Area (Sq.mt.)	Total FAR Area (Sq.mt.)
Ground Floor	90.14	90.14	90.14	90.14
First Floor	90.14	90.14	90.14	90.14
Terrace Floor	0.00	0.00	0.00	0.00
Total :	180.28	180.28	180.28	180.28

Building USE/SUBUSE Details

Building Name	Building Use	Building SubUse	Building Structure
A (RESIDENTIAL)	Residential	Residential Bldg/Apartment	Non-Highrise

FAR & Tenement Details (Table 4c-1)

Building	No. of Same Bldg	Total Built Up Area (Sq.mt.)	Proposed FAR Area (Sq.mt.) Resi.	Total FAR Area (Sq.mt.)	Total Consumed Additional FAR Area (Sq.mt.)	Tnmt (No.)
A (RESIDENTIAL)	1	180.28	180.28	180.28	180.28	01
Grand Total :	1	180.28	180.28	180.28	180.28	01

UnitBUA Table for Building :A (RESIDENTIAL)

FLOOR	Name	UnitBUA Type	UnitBUA Area	Carpet Area	No. of Rooms	No. of Tenement
GROUND FLOOR PLAN	SPLIT 1	FLAT	180.27	180.25	9	1
FIRST FLOOR PLAN	SPLIT 1	FLAT	0.00	0.00	9	0
Total:	-	-	180.27	180.25	18	1

SCHEDULE OF DOOR:

BUILDING NAME	NAME	LENGTH	HEIGHT	NOS
A (RESIDENTIAL)	D1	0.90	2.10	12
A (RESIDENTIAL)	D1	1.00	2.10	01

SCHEDULE OF WINDOW/VENTILATION:

BUILDING NAME	NAME	LENGTH	HEIGHT	NOS
A (RESIDENTIAL)	V	0.80	1.20	06
A (RESIDENTIAL)	W	1.82	1.20	16

Building :A (RESIDENTIAL)

Floor Name	Total Built Up Area (Sq.mt.)	Proposed FAR Area (Sq.mt.) Resi.	Total FAR Area (Sq.mt.)	Total Consumed Additional FAR Area (Sq.mt.)	Tnmt (No.)
Ground Floor	90.14	90.14	90.14	90.14	01
First Floor	90.14	90.14	90.14	90.14	00
Terrace Floor	0.00	0.00	0.00	0.00	00
Total :	180.28	180.28	180.28	180.28	01
Total Number of Same Buildings	1				
Total :	180.28	180.28	180.28	180.28	01

LTP NAME AND SIGNATURE	STRUCTURAL ENG'S NAME AND SIGNATURE	BUILDER NAME AND SIGNATURE	DIGITAL SIGNATURE
ASHOK KUMAR MADA/ENG/0007/2019			

Proposal Basic Information	
Proposal File No.	MADA/BP/0124/2020
Owner Name	SMT ANANTI DEVI
Khata No	OLD 20.42, NEW =40, 70
Plot No	(OLD 474, 476, 484) (NEW 475,476,1437)
Village Name	Jialgora
Use	Residential
SubUse	Bungalow/ Dwelling / Non Apartment

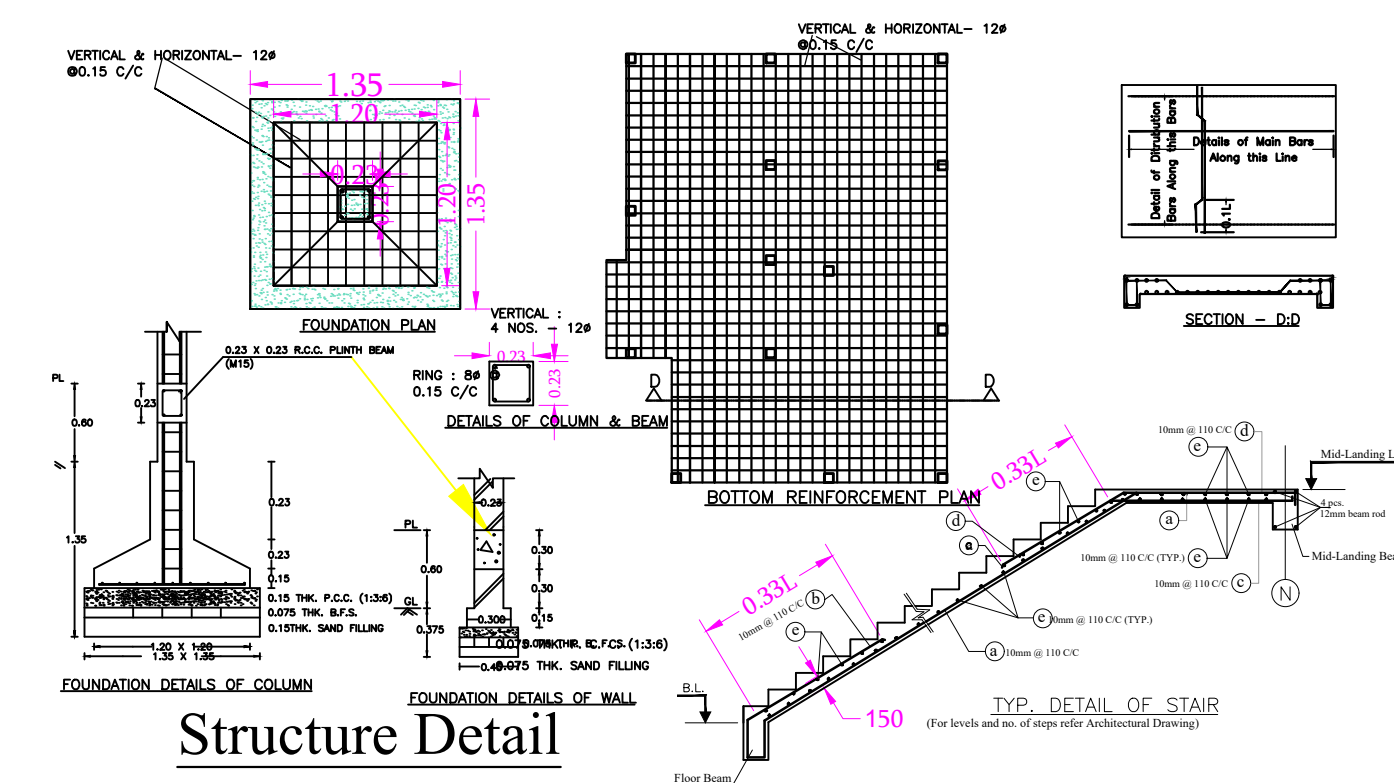
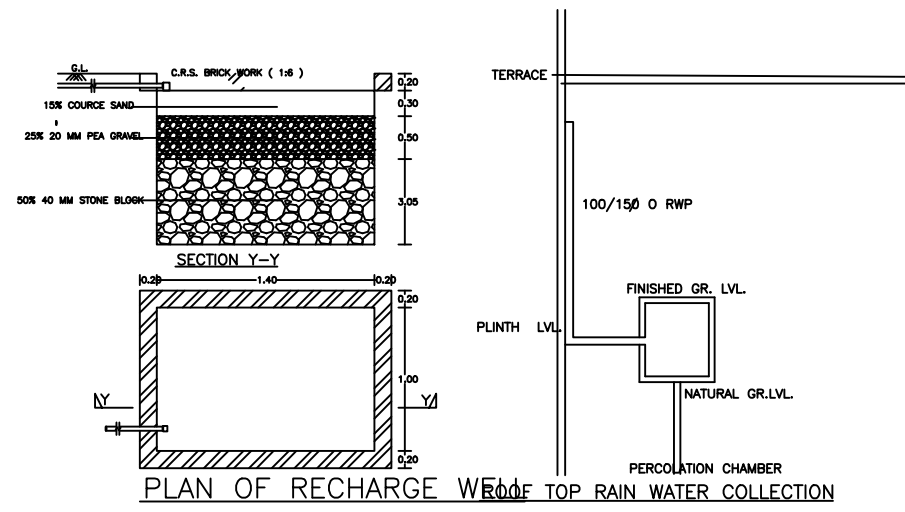
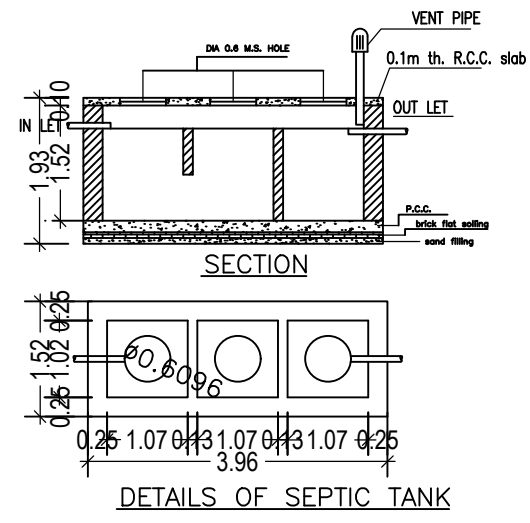
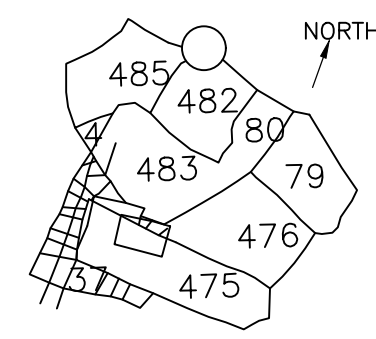
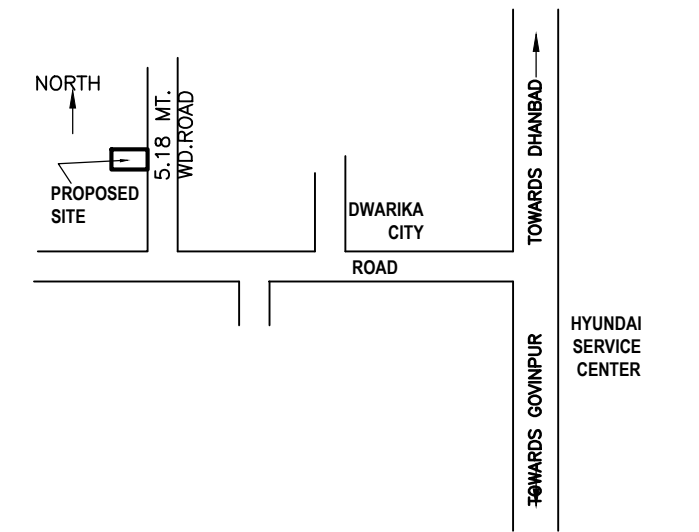
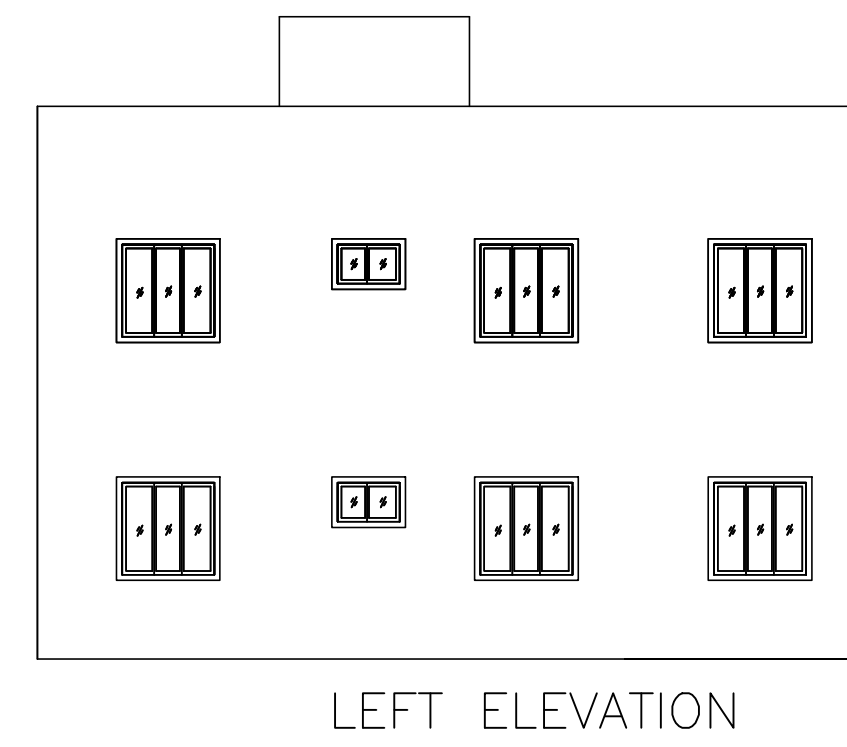
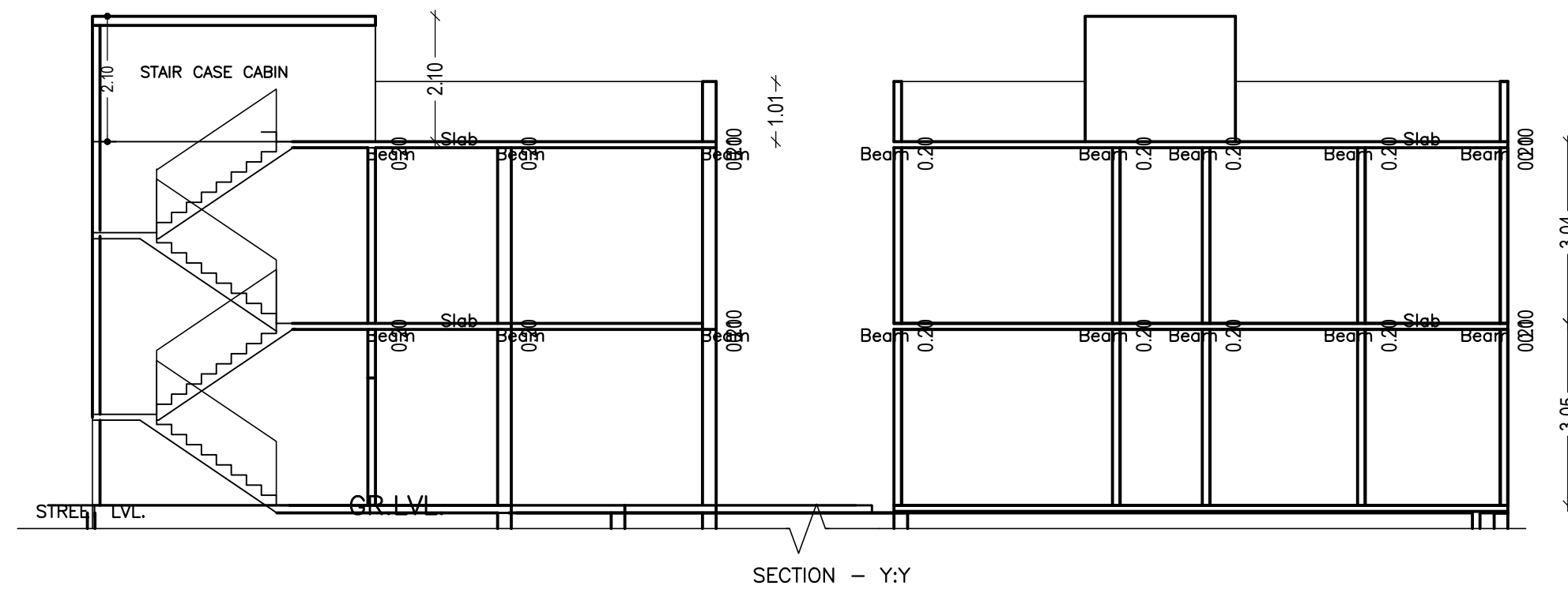
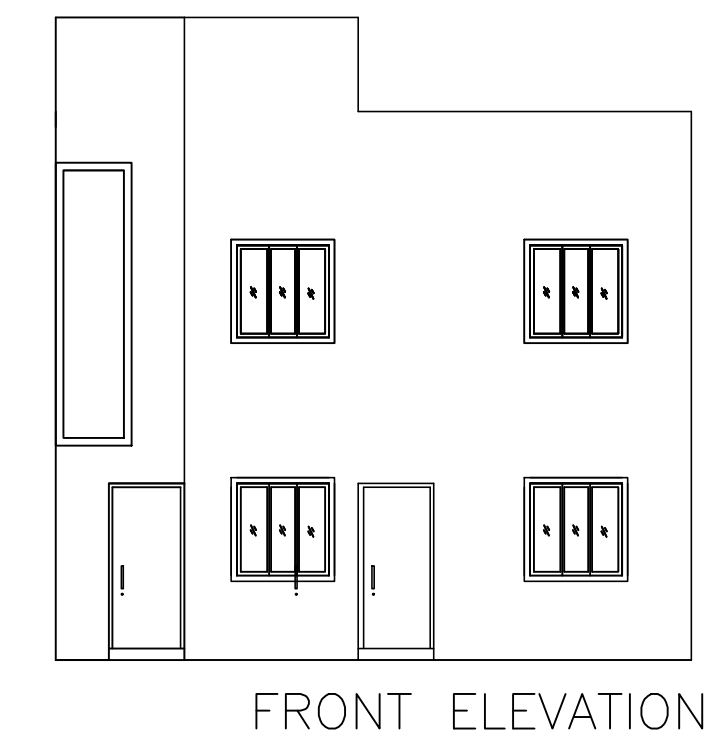
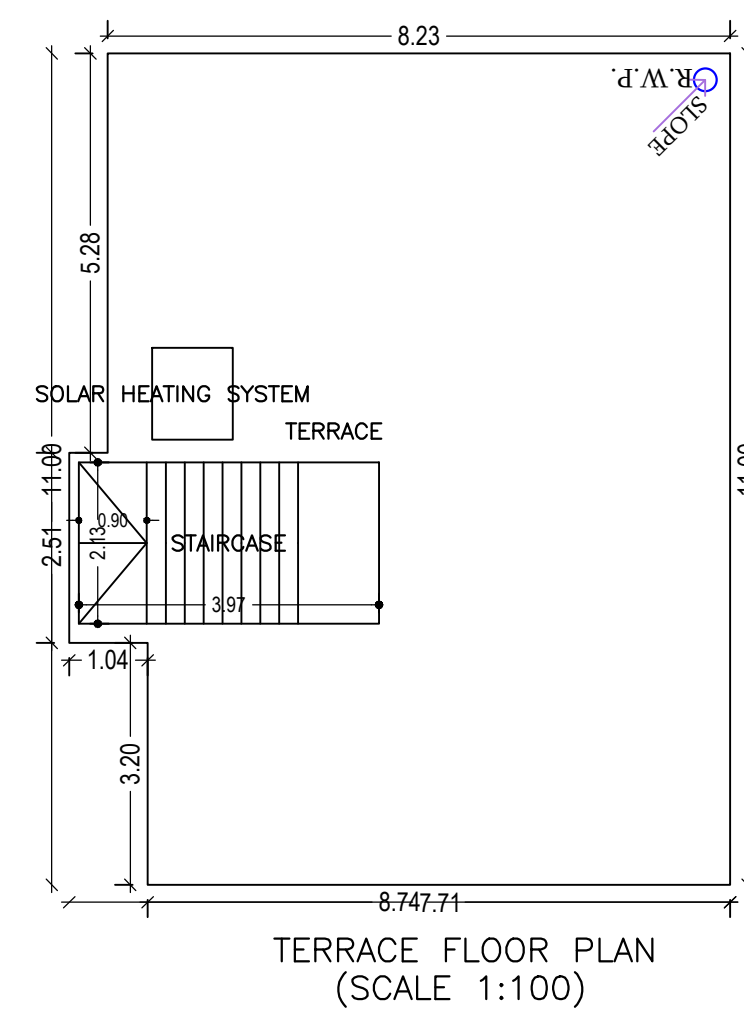
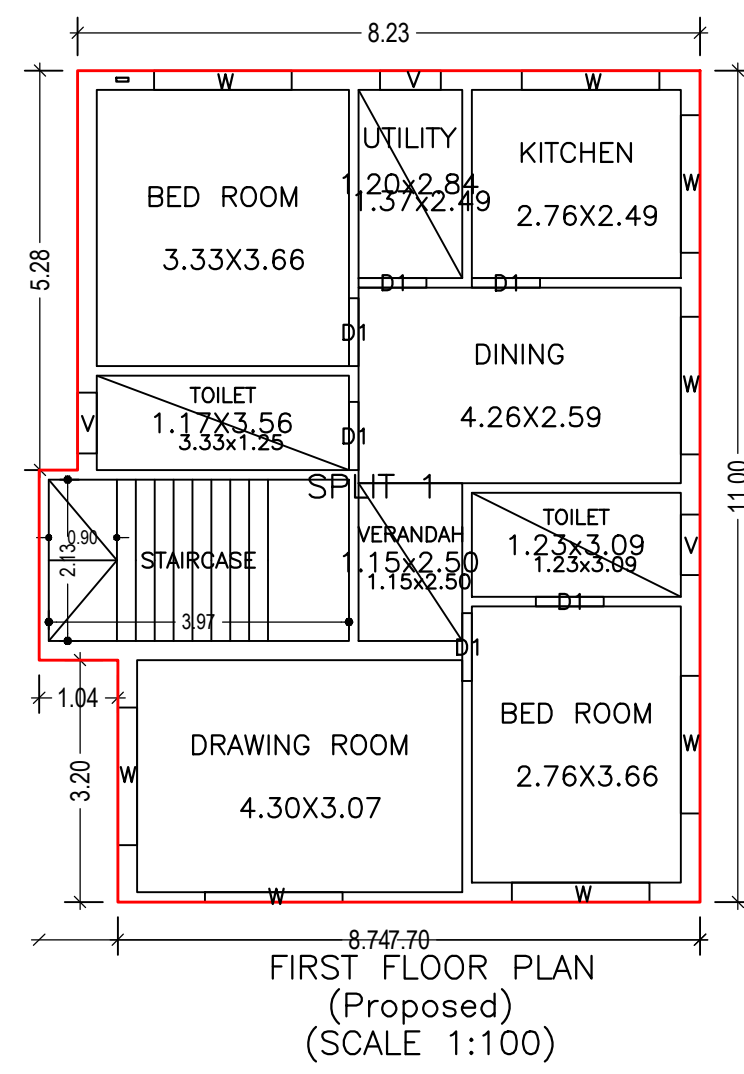
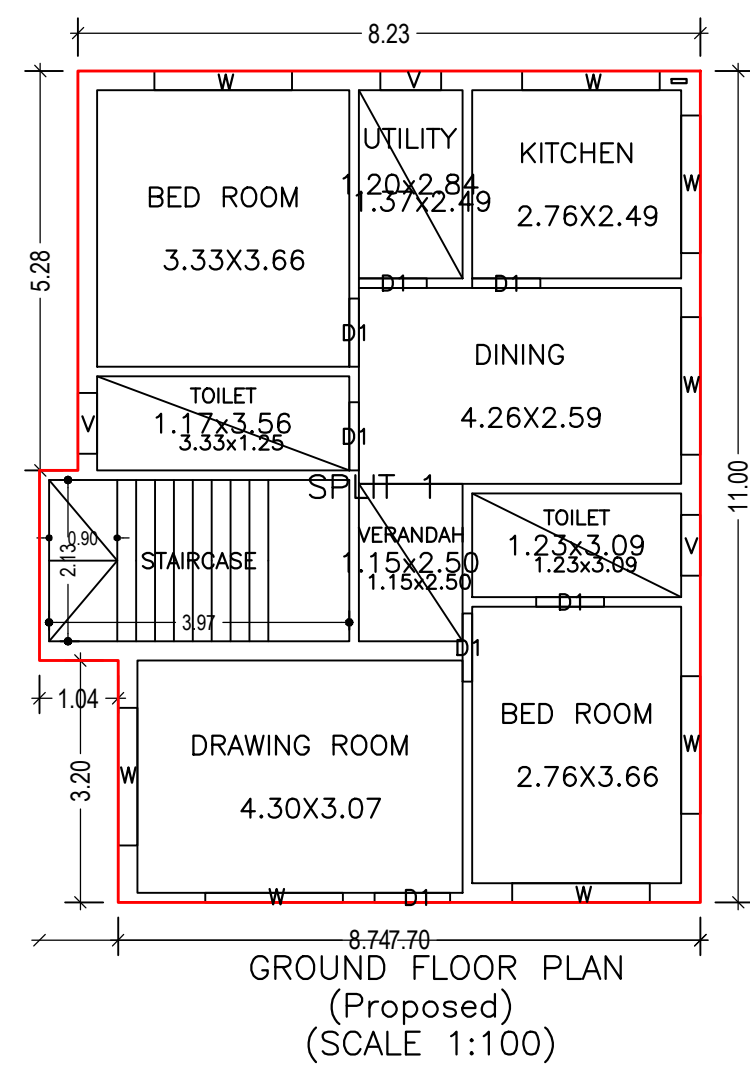

LTP NAME AND SIGNATURE	STRUCTURAL ENG'S NAME AND SIGNATURE	BUILDER NAME AND SIGNATURE	DIGITAL SIGNATURE
ASHOK KUMAR MADA/ENG/0007/2019			