

ANIL KUMAR MADAV, RAHUL MANDAL

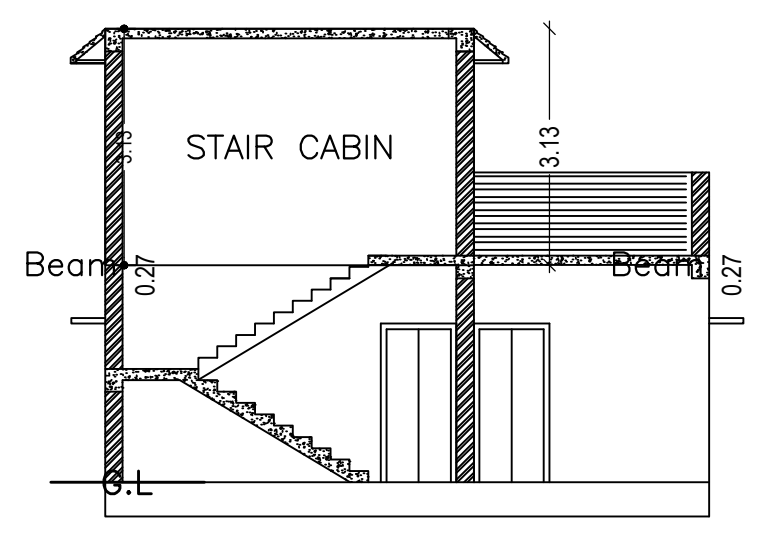

SECTION AT X-X

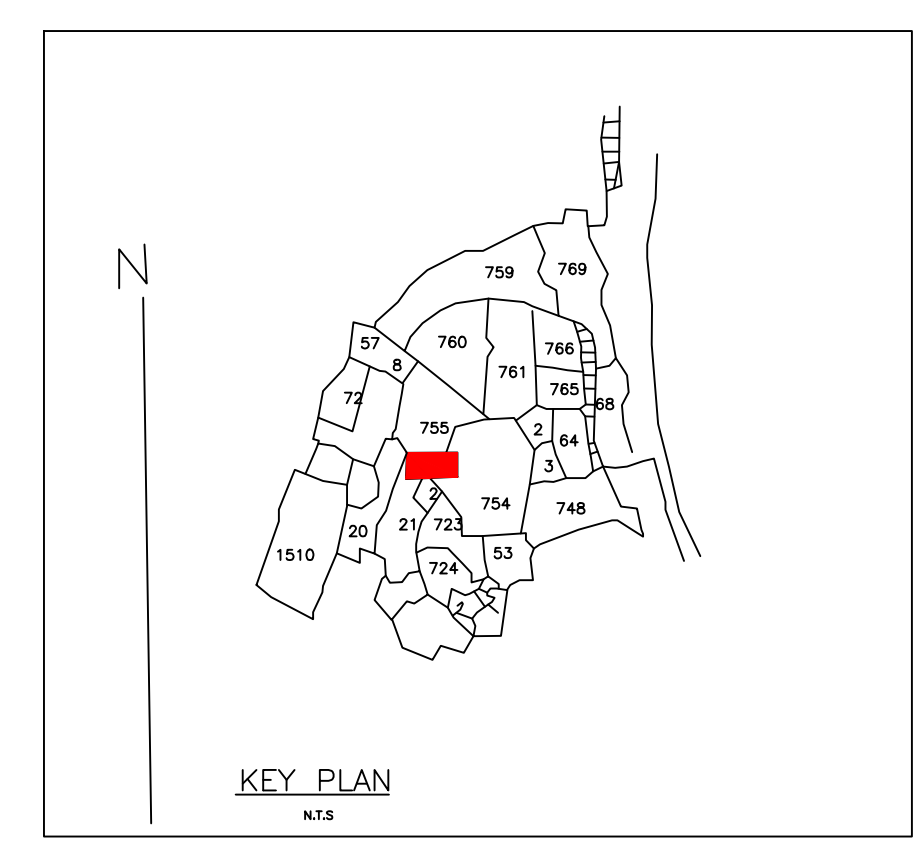
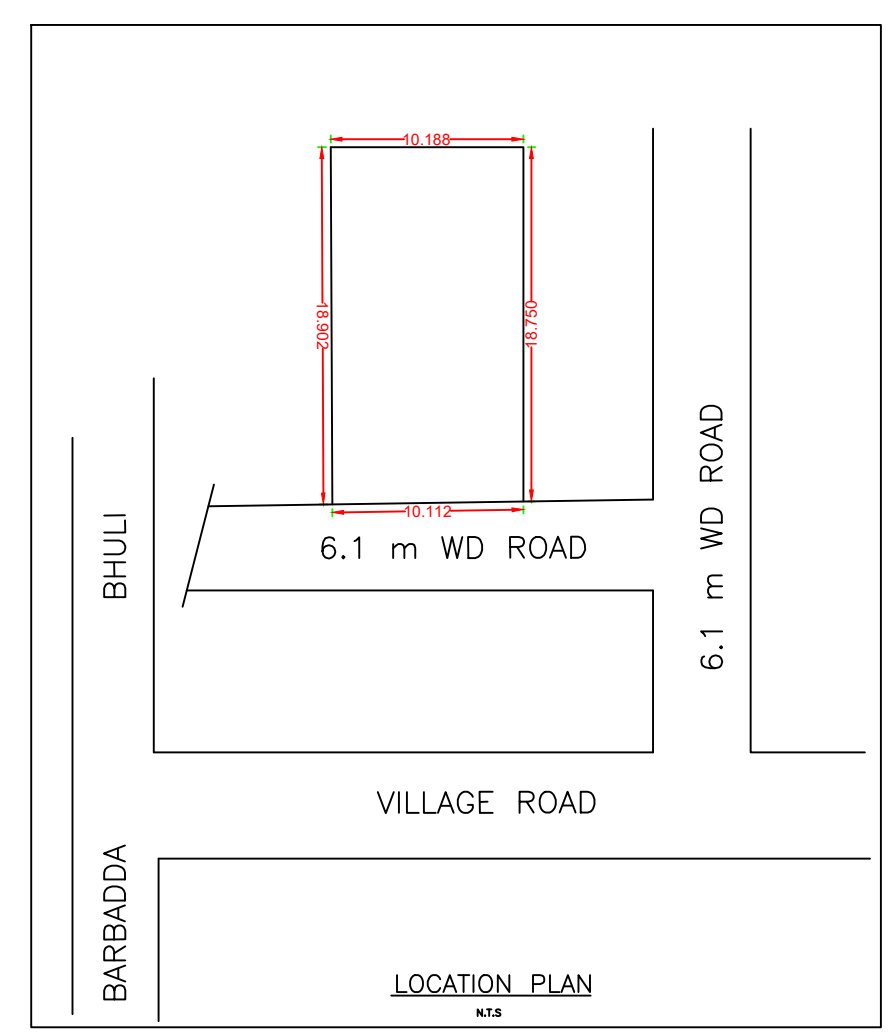
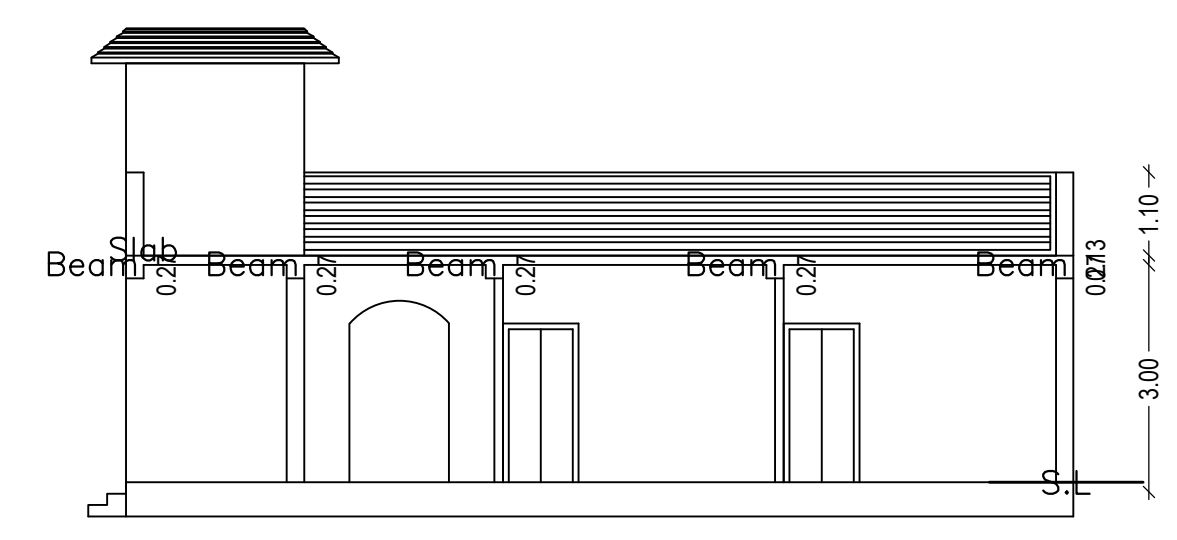

SECTION AT Y-Y

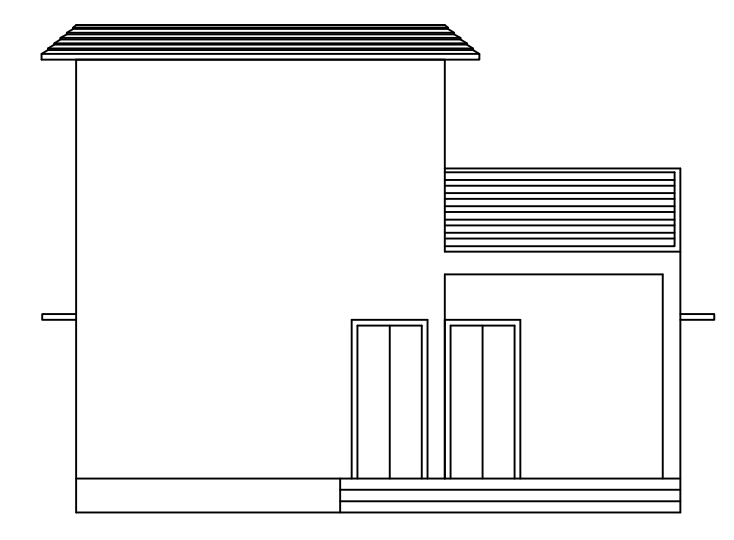

FRONT ELEVATION

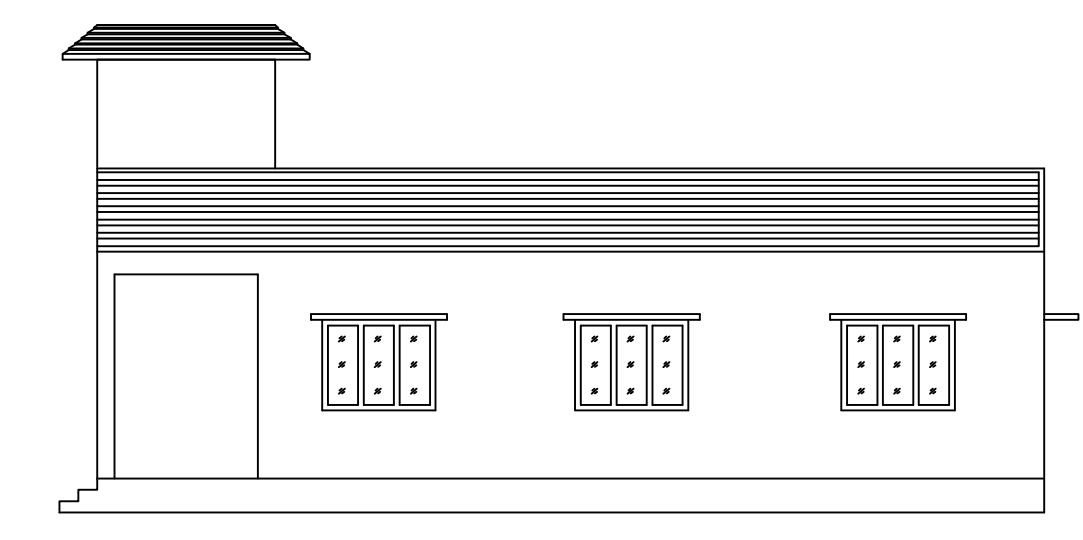

RIGHT SIDE ELEVATION

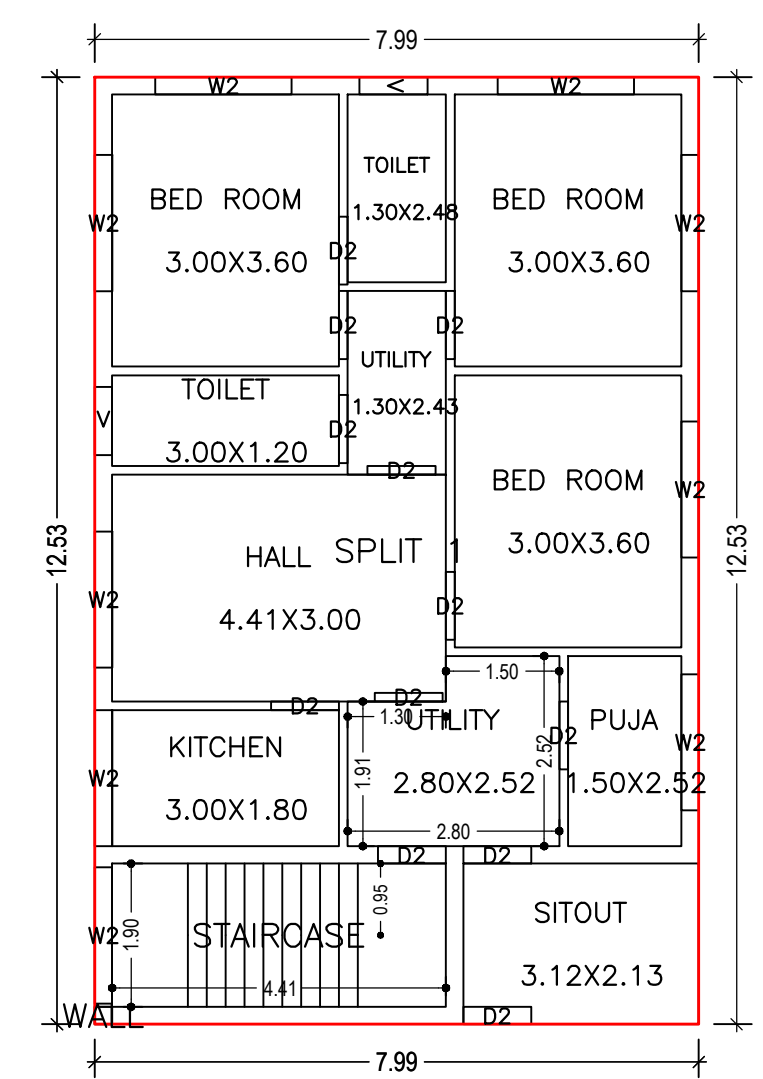

GROUND FLOOR PLAN (Proposed) (SCALE 1:100)

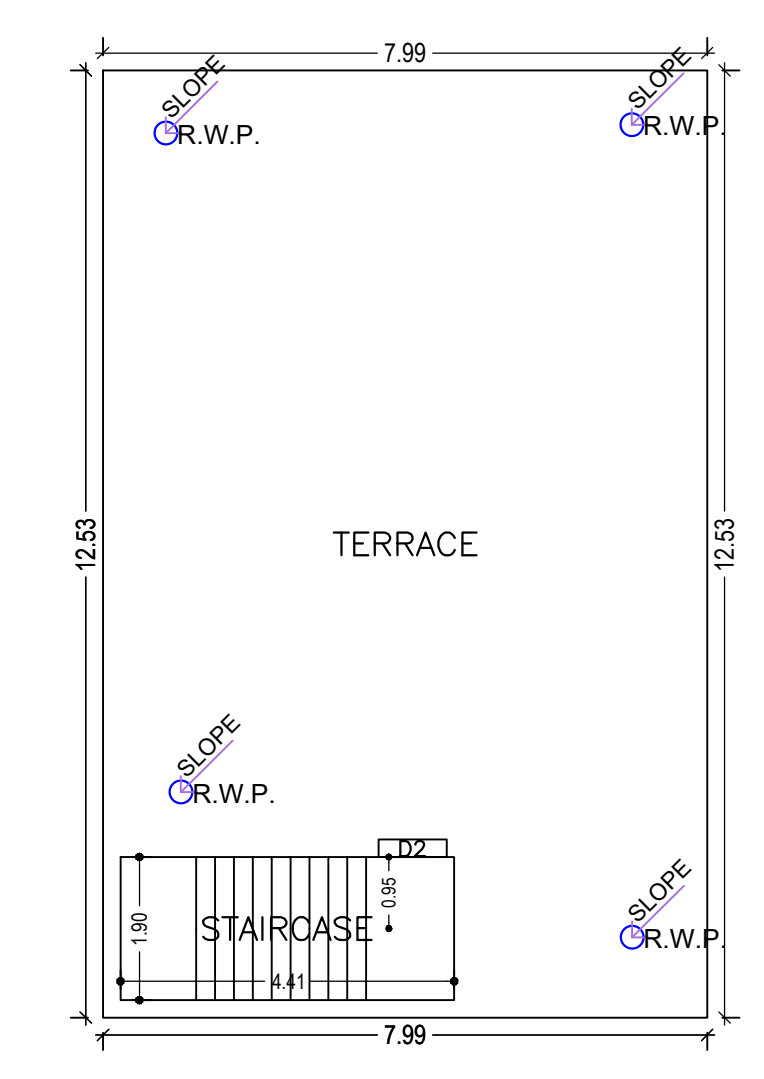

TERRACE FLOOR PLAN (SCALE 1:100)

SCHEDULE OF DOOR:

BUILDING NAME	NAME	LENGTH	HEIGHT	NOS
A (B)	D2	0.90	2.10	12

SCHEDULE OF WINDOW/VENTILATION:

BUILDING NAME	NAME	LENGTH	HEIGHT	NOS
A (B)	V	0.90	1.20	02
A (B)	W2	1.80	1.20	09

UnitBUA Table for Building :A (B)

FLOOR	Name	UnitBUA Type	UnitBUA Area	Carpet Area	No. of Rooms	No. of Tenement
GROUND FLOOR PLAN	SPLIT 1	FLAT	100.11	100.06	11	1
Total:	-	-	100.11	100.06	11	1

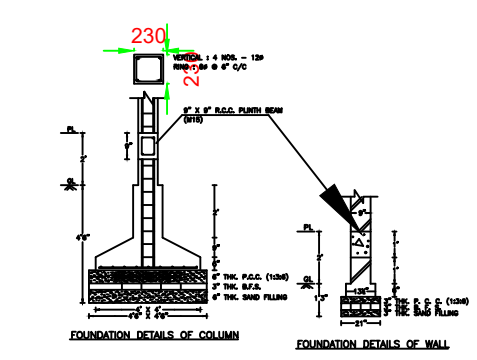
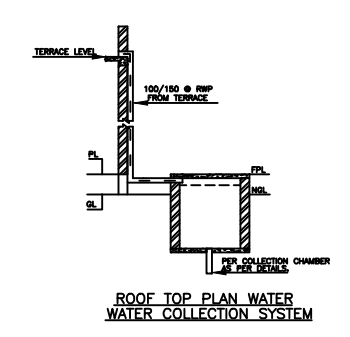
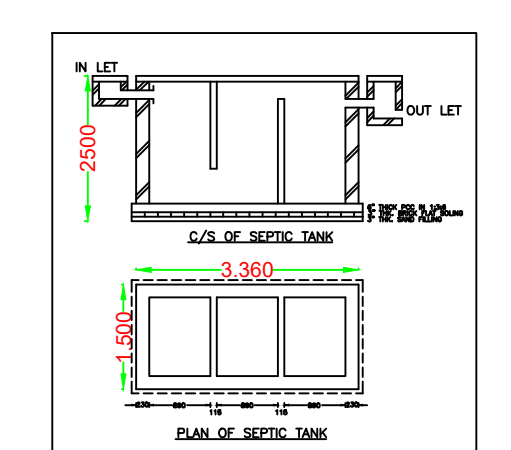
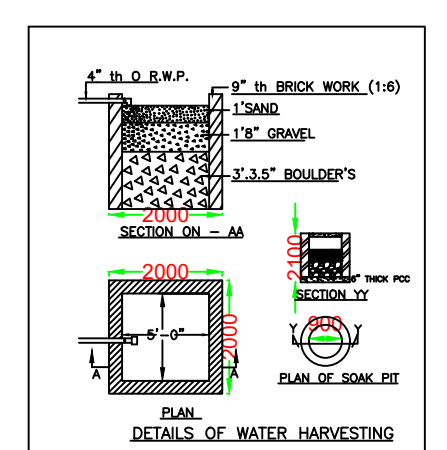

Proposal Basic Information

Proposal File No.	MADA/BP/0122/2020
Owner Name	RITA DEVI
Khata No	03,40,62 (O) 120, 121 (N)
Plot No	721,755, 754 (O) 1176,1013, 1015 (N),
Village Name	Nawadhi
Use	Residential
SubUse	Bungalow/ Dwelling / Non Apartment

AREA STATEMENT MINERAL AREA DEVELOPMENT AUTHORITY	VERSION NO.: 1.0.53	VERSION DATE: 16/10/2020
PROJECT DETAIL:		
Region: JHARKHAND URBAN LOCAL BODIES	Plot Use: Residential	
District: DHANBAD	Plot SubUse: Bungalow/ Dwelling / Non Apartment	
Authority: MINERAL AREA DEVELOPMENT AUTHORITY	PlotNearbyReligiousStructure: NA	
Inward No: MADA/BP/0122/2020	Plot/SubPlot No: 721,755, 754 (O) 1176,1013, 1015 (N),	
Application Type: General Proposal	North: Plot No. - ANIL KUMAR YADAV, RAHUL MANDAL	
Project Type: Building Permission	South: Plot No. - PART OF PLOT NO. 721, 722, AND 754	
Nature of Development: New	East: Road Width - 6.1	
Location of Development Area: Old Area	West: Plot No. - SIMA MOUZA KALAKUSMA	
AREA DETAILS:		
AREA OF PLOT (Minimum)	(A)	SQ.MT. 191.07
NET AREA OF PLOT(Gross Plot Area - Deduction from Gross Plot area)	(A-Deductions)	191.07
Deduction for Balance Plot Area(from Gross Plot Area)		
Common Plot		37.46
Total		37.46
BALANCE AREA OF PLOT(Net Plot Area - Recreational/Amenity space)	(A-Deductions)	153.62
PLOT AREA FOR COVERAGE(Net Plot Area)	(A-Deductions)	191.07
Plot Area for FAR (Net Plot Area + Road/Widening Area)	(A-Deductions)	191.07
COVERAGE CHECK		
Permissible Coverage area (70.00 %)		133.75
Proposed Coverage Area (52.39 %)		100.11
Total Prop. Coverage Area (52.39 %)		100.11
Balance coverage area (17.61 %)		33.64
FAR CHECK		
Perm. FAR Area (2.50)		477.68
Total Perm. FAR area		477.68
Residential FAR		100.11
Proposed FAR Area		100.11
Total Proposed FAR Area		100.11
Consumed FAR (Factor)		0.52
Balance FAR Area		377.57
BUILT UP AREA CHECK		
Total Proposed BuiltUp Area		100.11
ARCHITECT (Regd)		JITENDAR KUMAR
ENGINEER (Regd)		
SUPERVISOR (Regd)		
OWNER (Regd)		RITA DEVI
DEVELOPMENT AUTHORITY		LOCAL BODY

COLOR INDEX

PLOT BOUNDARY	Black
ABUTTING ROAD	Green
PROPOSED CONSTRUCTION	Red
COMMON PLOT	Yellow
ROAD WIDENING AREA	Blue
EXISTING (To be retained)	Light Blue
EXISTING (To be demolished)	Dark Blue

Buildingwise Floor FAR Details

Floor Name	Building Name A (B)		Total	
	Proposed Built Up Area (Sq.mt.)	Proposed FAR Area (Sq.mt.)	Total Proposed Built Up Area (Sq.mt.)	Total FAR Area (Sq.mt.)
Ground Floor	100.11	100.11	100.11	100.11
Terrace Floor	0.00	0.00	0.00	0.00
Total:	100.11	100.11	100.11	100.11

Building USE/SUBUSE Details

Building Name A (B)	Building Use	Building SubUse		Building Structure
		Residential	Residential Bldg/Apartment	
A (B)	Residential			

FAR & Tenement Details (Table 4c-1)

Building	No. of Same Bldg	Total Built Up Area (Sq.mt.)	Proposed FAR Area (Sq.mt.) Resi.	Total FAR Area (Sq.mt.)	Total Consumed Additional FAR Area (Sq.mt.)	Tnmt (No.)
A (B)	1	100.11	100.11	100.11	100.11	01
Grand Total :	1	100.11	100.11	100.11	100.11	01

Building :A (B)

Floor Name	Total Built Up Area (Sq.mt.)	Proposed FAR Area (Sq.mt.) Resi.	Total FAR Area (Sq.mt.)	Total Consumed Additional FAR Area (Sq.mt.)	Tnmt (No.)
Ground Floor	100.11	100.11	100.11	100.11	01
Terrace Floor	0.00	0.00	0.00	0.00	00
Total :	100.11	100.11	100.11	100.11	01
Total Number of Same Buildings	1				
Total :	100.11	100.11	100.11	100.11	01

LTP NAME AND SIGNATURE	STRUCTURAL ENG'S NAME AND SIGNATURE	BUILDER NAME AND SIGNATURE	DIGITAL SIGNATURE
JITENDAR KUMAR MADA/DFTMN/0005/2020			