

Building :AA (AA)

Floor Name	Total Built Up Area (Sq.mt.)	Proposed FAR Area (Sq.mt.)	Total FAR Area (Sq.mt.)	Total Consumed Additional FAR Area (Sq.mt.)	Tnmt (No.)
Ground Floor	91.32	91.32	91.32	91.32	01
First Floor	91.32	91.32	91.32	91.32	00
Terrace Floor	0.00	0.00	0.00	0.00	00
Total	182.64	182.64	182.64	182.64	01
Total Number of Same Buildings	1				
Total	182.64	182.64	182.64	182.64	01

UnitBUA Table for Building :AA (AA)

FLOOR	Name	UnitBUA Type	UnitBUA Area	Carpet Area	No. of Rooms	No. of Tenement
GROUND FLOOR PLAN	SPLIT AA	FLAT	182.65	182.26	7	1
FIRST FLOOR PLAN	SPLIT AA	FLAT	0.00	0.00	7	0
Total	-	-	182.65	182.26	14	1

FAR & Tenement Details (Table 4c-1)

Building	No. of Same Bldg	Total Built Up Area (Sq.mt.)	Proposed FAR Area (Sq.mt.)	Total FAR Area (Sq.mt.)	Total Consumed Additional FAR Area (Sq.mt.)	Tnmt (No.)
AA (AA)	1	182.64	182.64	182.64	182.64	01
Grand Total	1	182.64	182.64	182.64	182.64	01

DETAIL OF COLUMNS

WATER HARVESTING

Proposal Basic Information

Proposal File No.	MADA/BP/0120/2020
Owner Name	SMT PRITI DEVI
Khata No	OLD - 40 , NEW - 121
Plot No	OLD - 755,758,760, NEW - 1008,1009,1013
Village Name	Nawadih
Use	Residential
SubUse	Bungalow/ Dwelling / Non Apartment

AREA STATEMENT MINERAL AREA DEVELOPMENT AUTHORITY

Version No.:	1.0.53	
Version Date:	16/10/2020	
Region:	JHARKHAND URBAN LOCAL BODIES	
District:	DHANBAD	
Authority:	MINERAL AREA DEVELOPMENT AUTHORITY	
Plot SubUse:	Bungalow/ Dwelling / Non Apartment	
Plot Nearby/Religious/Structure:	NA	
Inward No.:	MADA/BP/0120/2020	
Plot/SubPlot No.:	OLD - 755,758,760, NEW - 1008,1009,1013	
Application Type:	General Proposal	
Project Type:	Building Permission	
Nature of Development:	New	
Location of Development Area:	Old Area	
Area of Plot (Minimum):	(A)	161.85
NET AREA OF PLOT (Gross Plot Area - Deduction from Gross Plot Area):	(A-Deductions)	161.85
Deduction for Balance Plot Area (from Gross Plot Area):		
Common Plot Total:		18.08
BALANCE AREA OF PLOT (Net Plot Area - Recreational/Amenity space):	(A-Deductions)	143.77
PLOT AREA FOR COVERAGE (Net Plot Area):	(A-Deductions)	161.85
Plot Area for FAR (Net Plot Area + Road Widening Area):	(A-Deductions)	161.85
COVERAGE CHECK		
Permissible Coverage area (70.00 %)		113.30
Proposed Coverage Area (56.42 %)		91.32
Total Prop. Coverage Area (56.42 %)		91.32
Balance coverage area (13.58 %)		21.98
FAR CHECK		
Perm. FAR Area (2.50)		404.63
Total Perm. FAR area		404.63
Residential FAR		182.65
Proposed FAR Area		182.65
Total Proposed FAR Area		182.65
Consumed FAR (Factor)		1.13
Balance FAR Area		221.98
BUILT UP AREA CHECK		
Total Proposed BuiltUp Area		182.64
ARCHITECT (Regd)		AMARENDRA KUMAR
ENGINEER (Regd)		
SUPERVISOR (Regd)		
OWNER (Regd)		SMT PRITI DEVI
DEVELOPMENT AUTHORITY		LOCAL BODY

COLOR INDEX

PLOT BOUNDARY	Black
ABUTTING ROAD	Green
PROPOSED CONSTRUCTION	Red
COMMON PLOT	Yellow
ROAD WIDENING AREA	Blue
EXISTING (To be retained)	Orange
EXISTING (To be demolished)	Light Blue

Buildingwise Floor FAR Details

Floor Name	Building Name AA (AA)		Total	
	Proposed Built Up Area (Sq.mt.)	Proposed FAR Area (Sq.mt.)	Total Proposed Built Up Area (Sq.mt.)	Total FAR Area (Sq.mt.)
Ground Floor	91.32	91.32	91.32	91.32
First Floor	91.32	91.32	91.32	91.32
Terrace Floor	0.00	0.00	0.00	0.00
Total	182.64	182.64	182.64	182.64

Building USE/SUBUSE Details

Building Name	Building Use	Building SubUse	Building Structure
AA (AA)	Residential	Bungalow/ Dwelling / Non Apartment	Non-Highrise

SCHEDULE OF DOOR:

BUILDING NAME	NAME	LENGTH	HEIGHT	NOS
AA (AA)	D	0.81	2.10	02
AA (AA)	D	0.90	2.10	06
AA (AA)	D	1.05	2.10	06
AA (AA)	D	1.20	2.10	01

SCHEDULE OF WINDOW/VENTILATION:

BUILDING NAME	NAME	LENGTH	HEIGHT	NOS
AA (AA)	W	0.60	1.20	04
AA (AA)	W	1.03	1.20	01
AA (AA)	W	1.20	1.20	05
AA (AA)	W	1.80	1.20	06
AA (AA)	W	2.40	1.20	02

LTP NAME AND SIGNATURE AMARENDRA KUMAR MADA/ENG/0008/2019	STRUCTURAL ENG'S NAME AND SIGNATURE	BUILDER NAME AND SIGNATURE	DIGITAL SIGNATURE
---	-------------------------------------	----------------------------	-------------------

Proposal Basic Information

Proposal File No.	MADA/BP/0120/2020
Owner Name	SMT PRITI DEVI
Khata No	OLD - 40 , NEW - 121
Plot No	OLD - 755,758,760, NEW - 1008,1009,1013
Village Name	Nawadhi
Use	Residential
SubUse	Bungalow/ Dwelling / Non Apartment

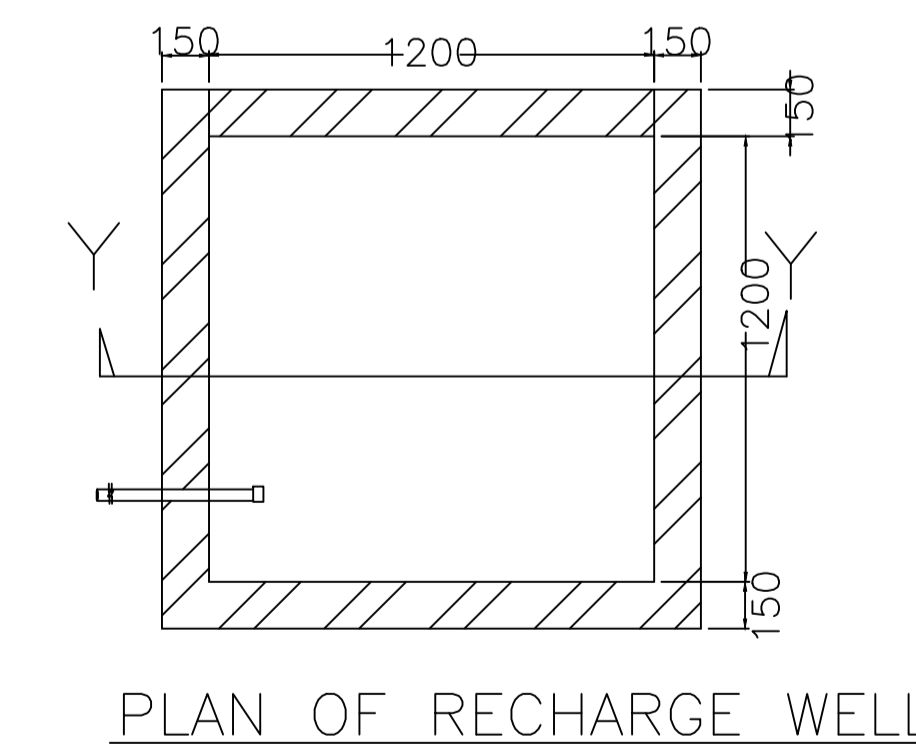
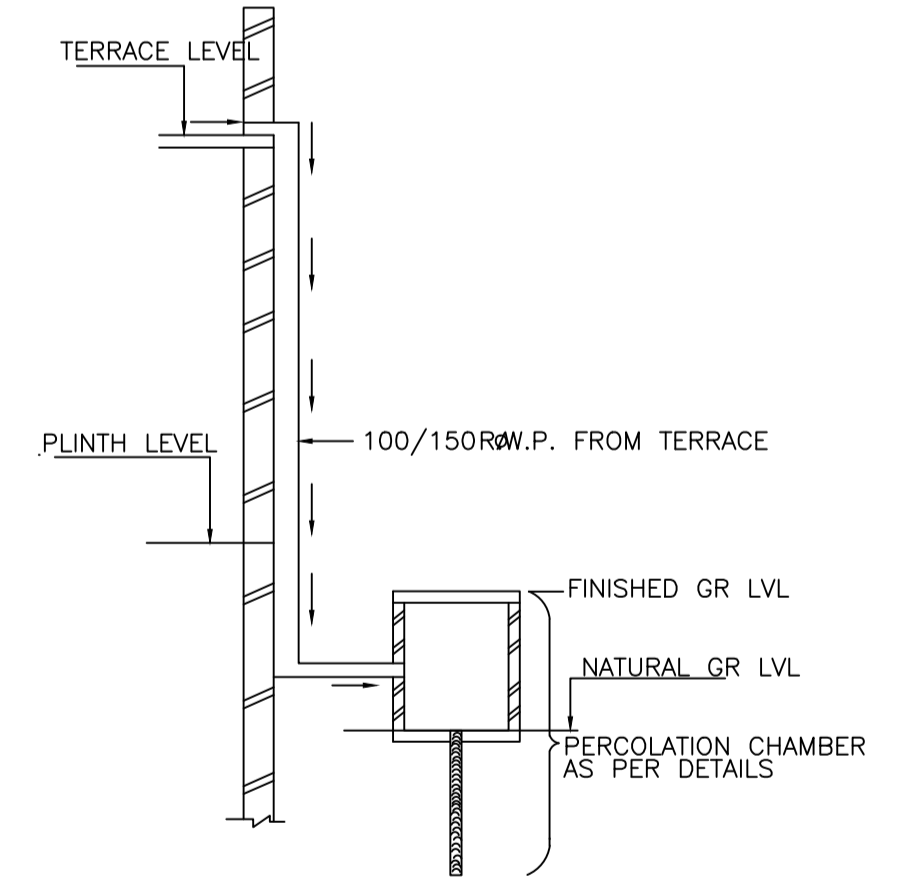
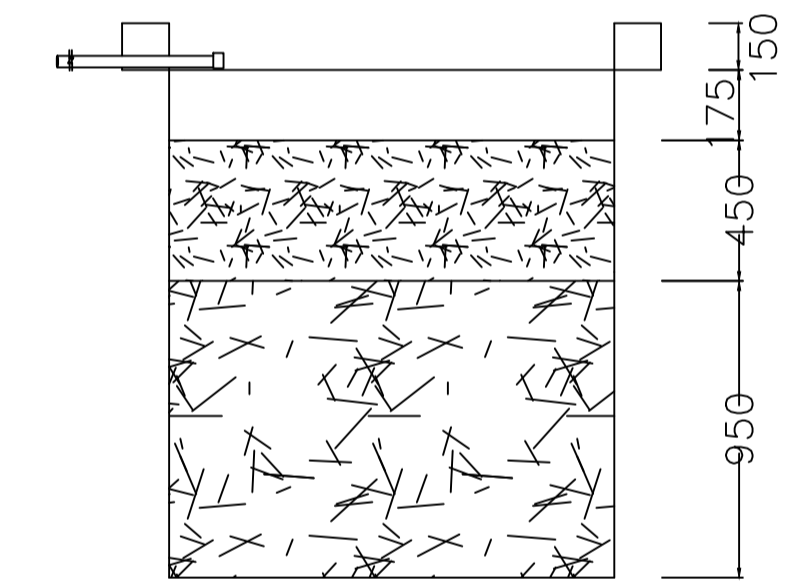
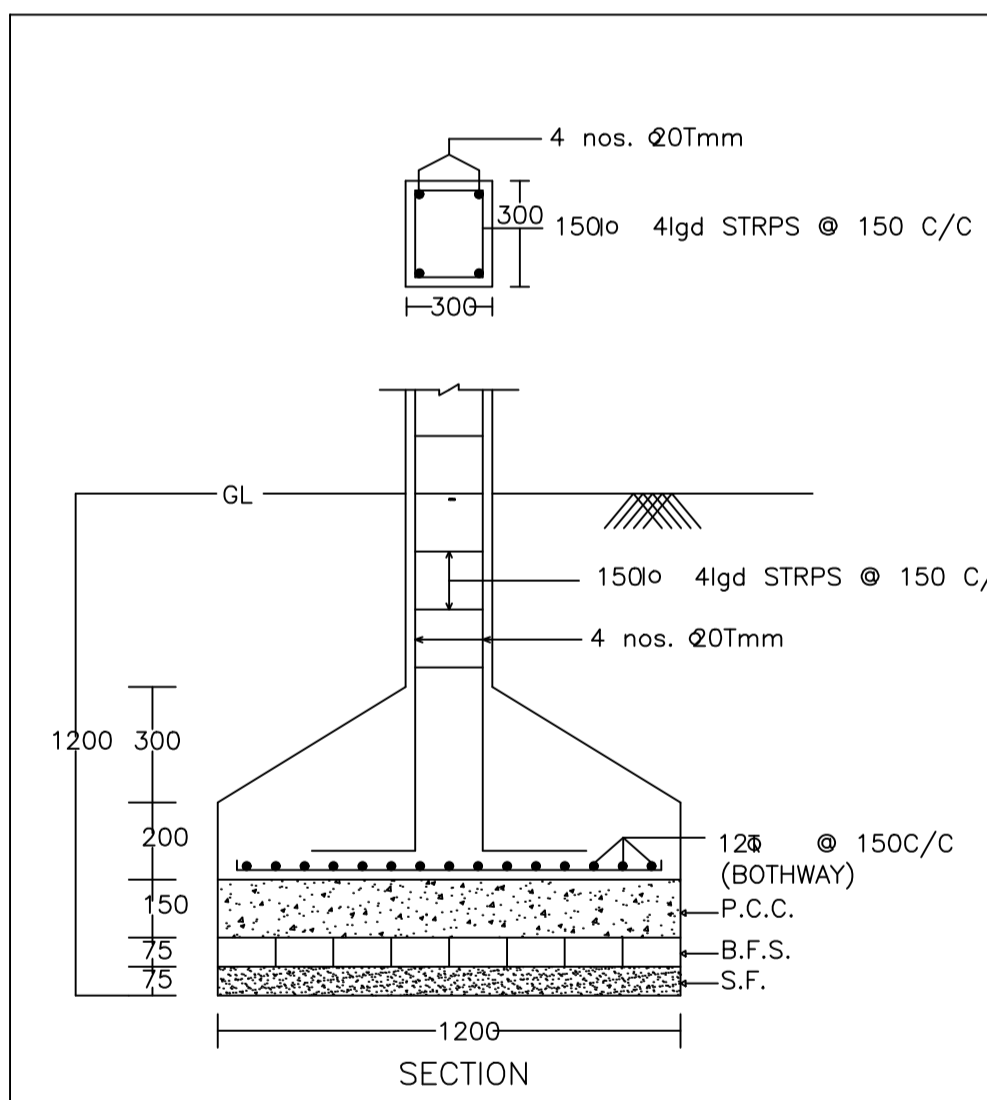
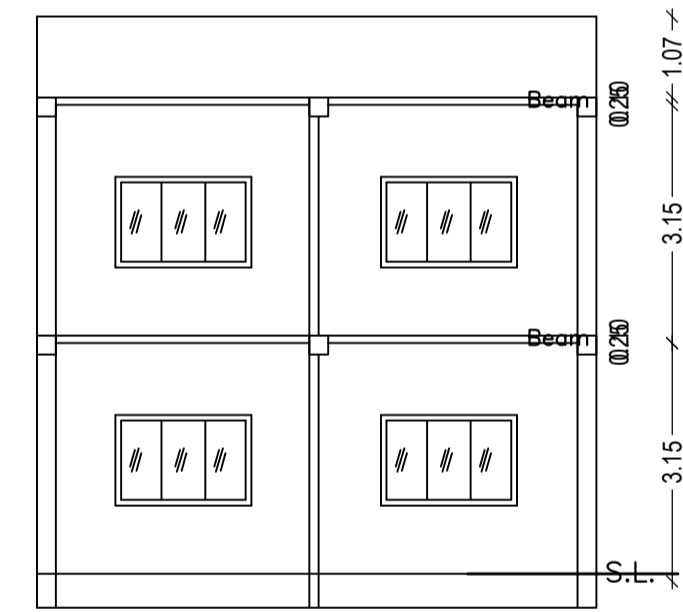
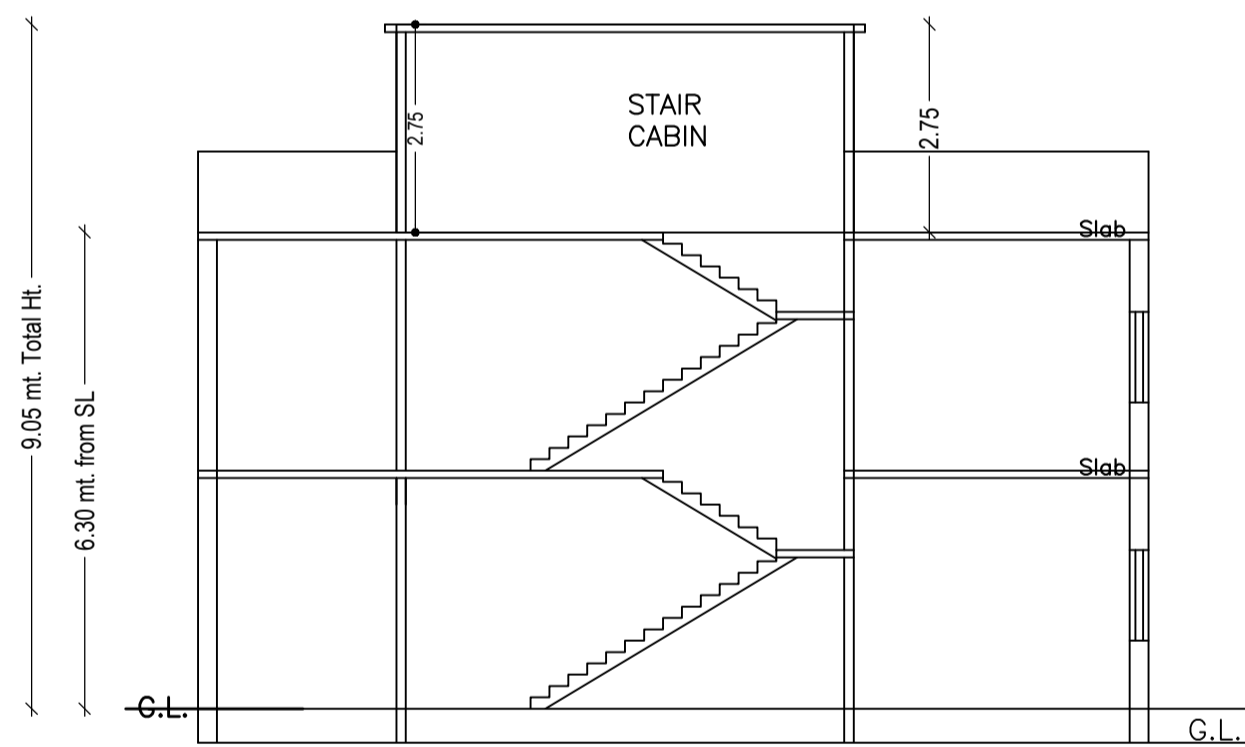
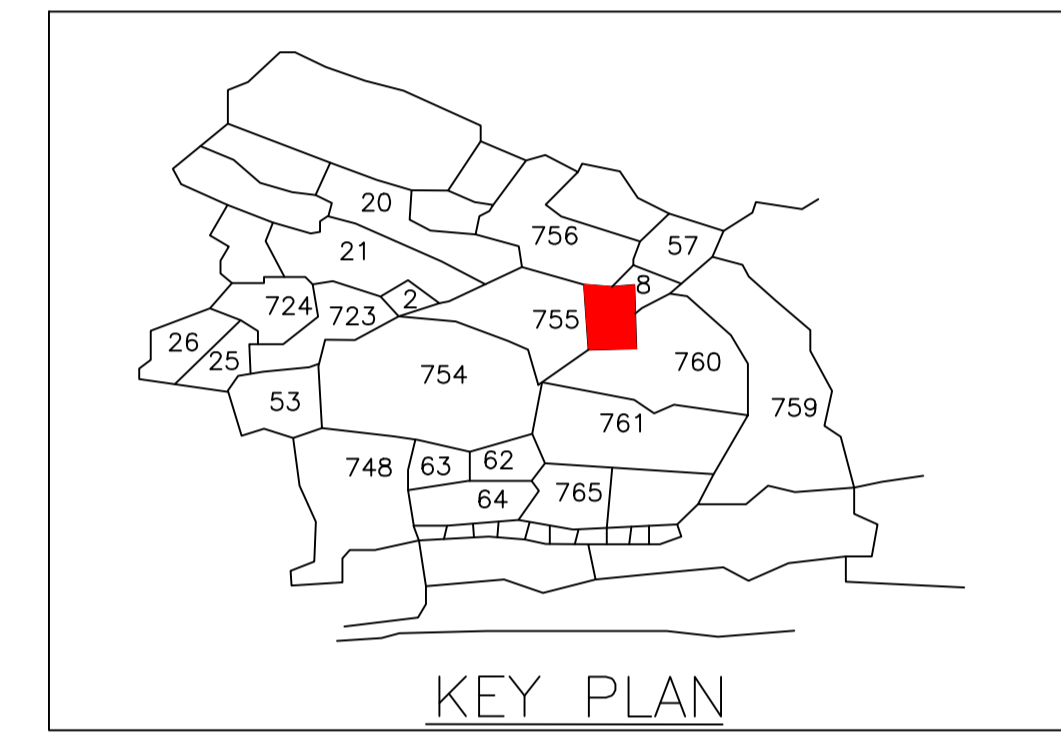
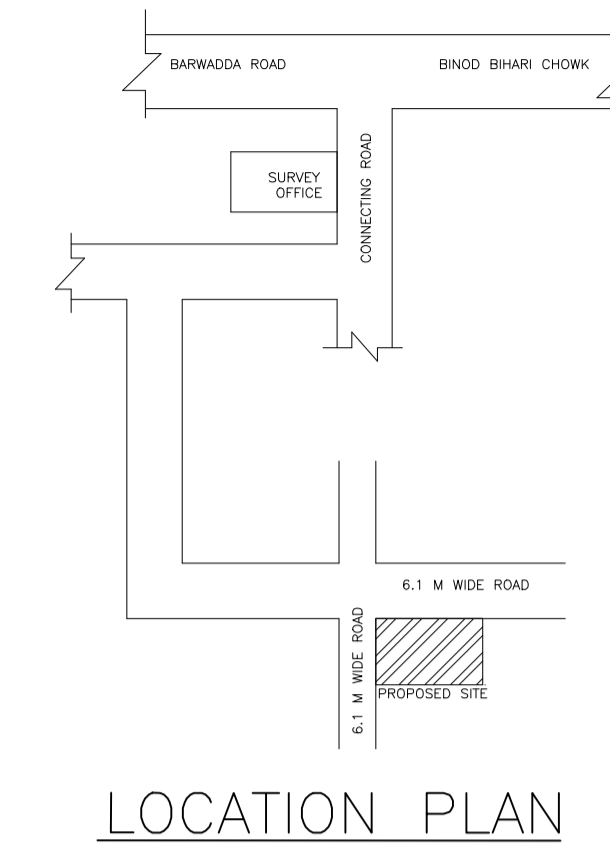
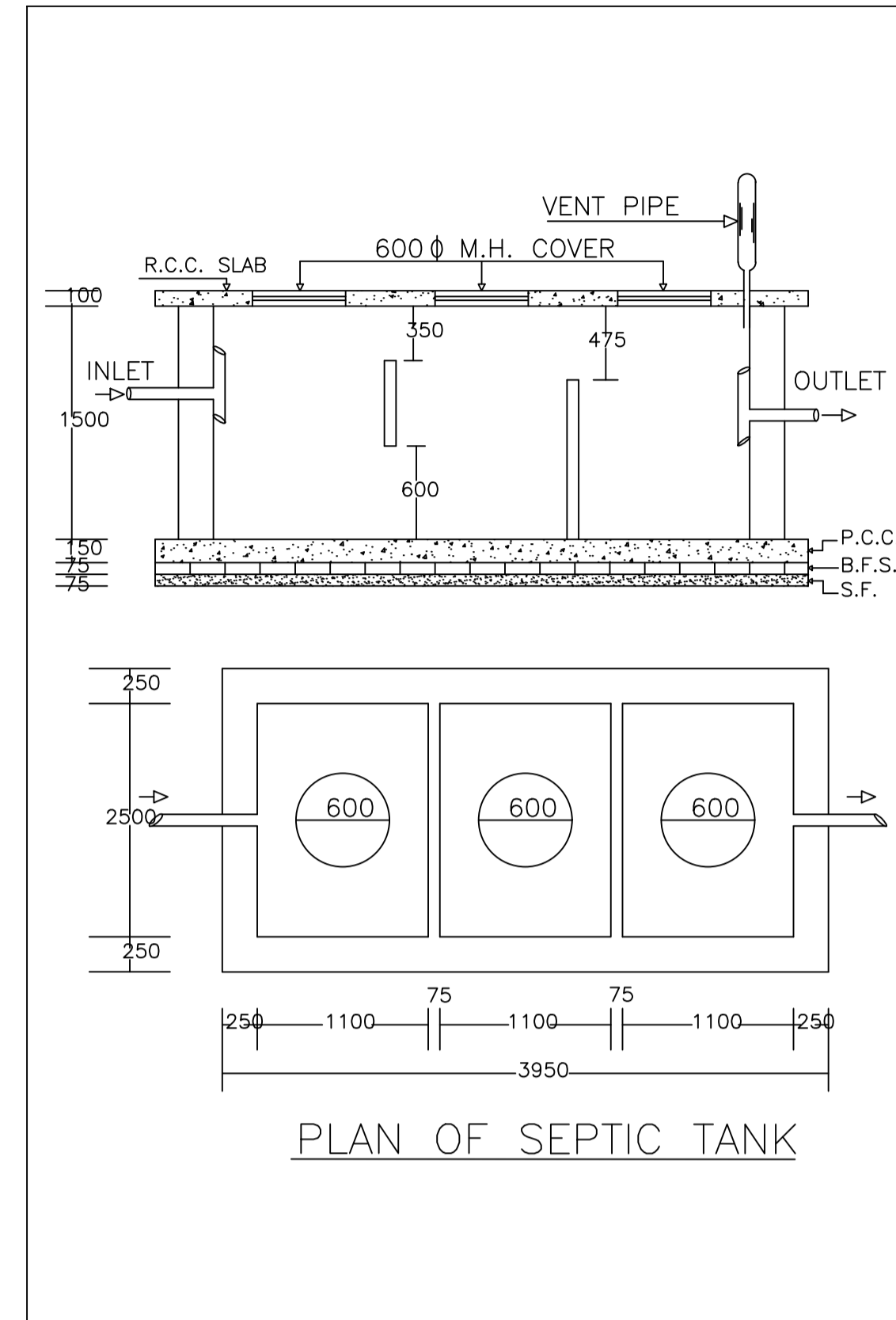
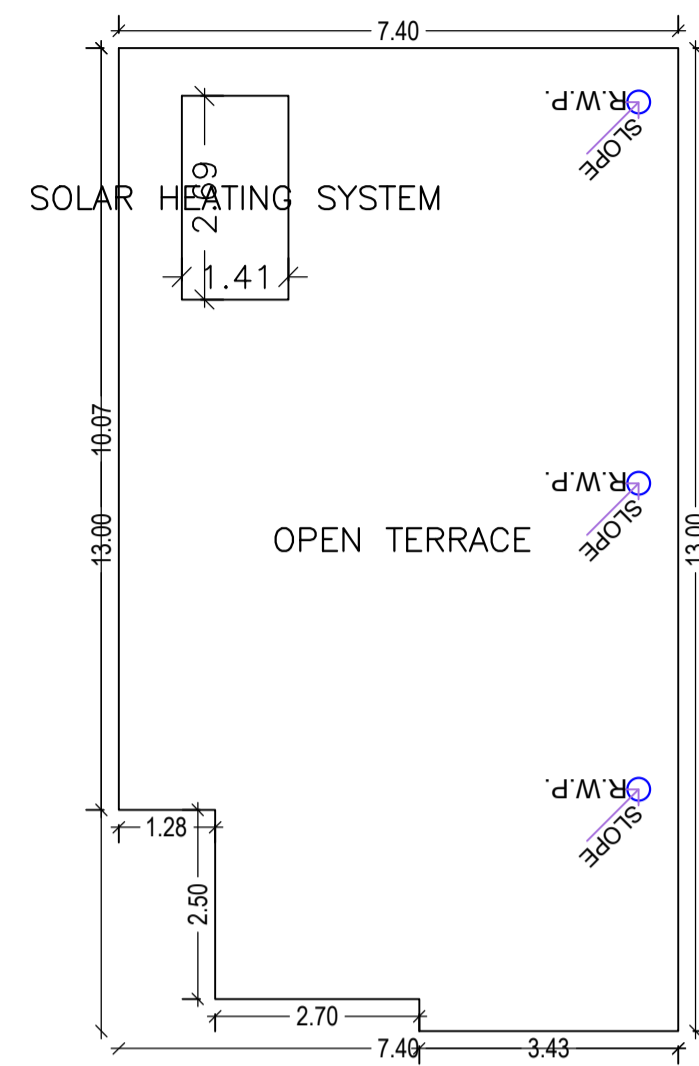
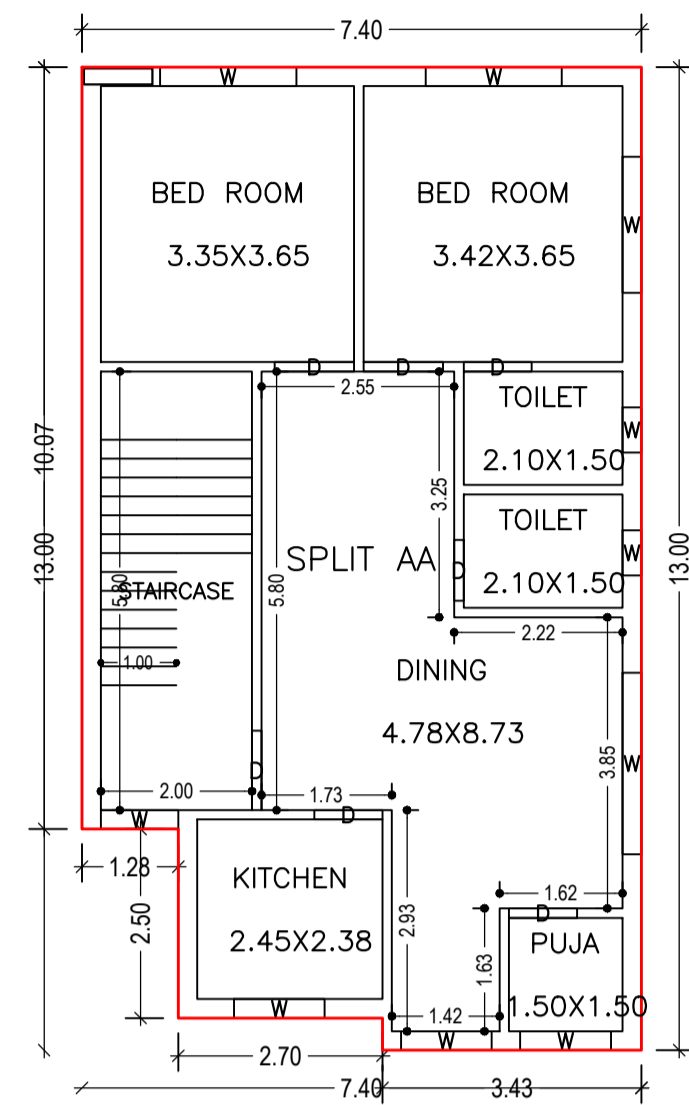
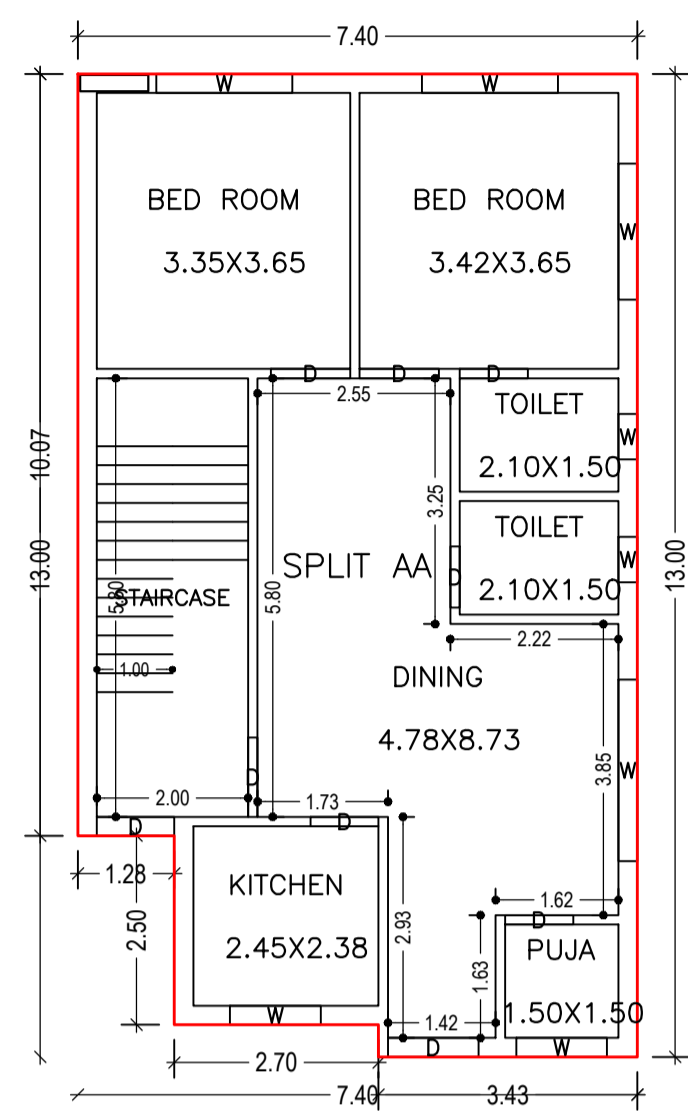

WATER HARVESTING

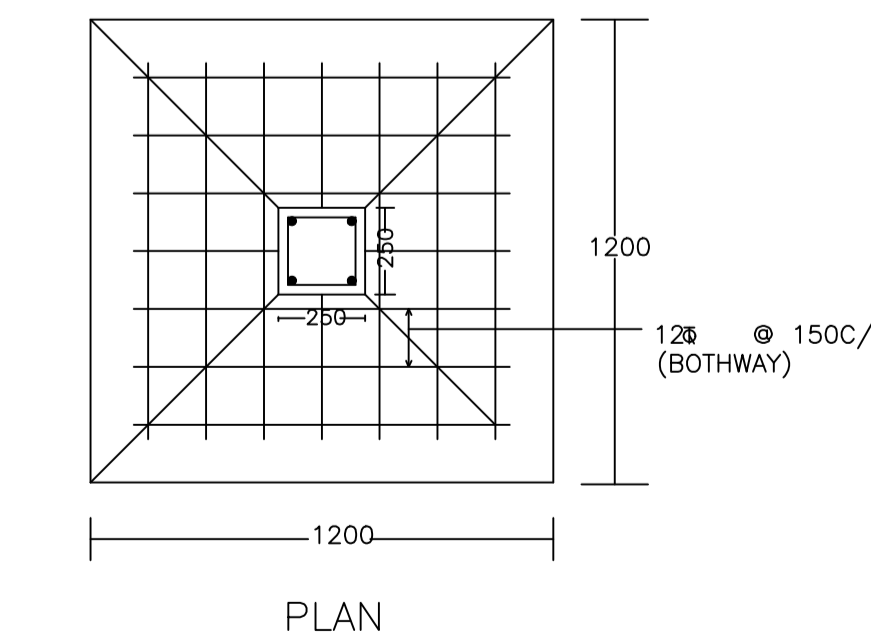
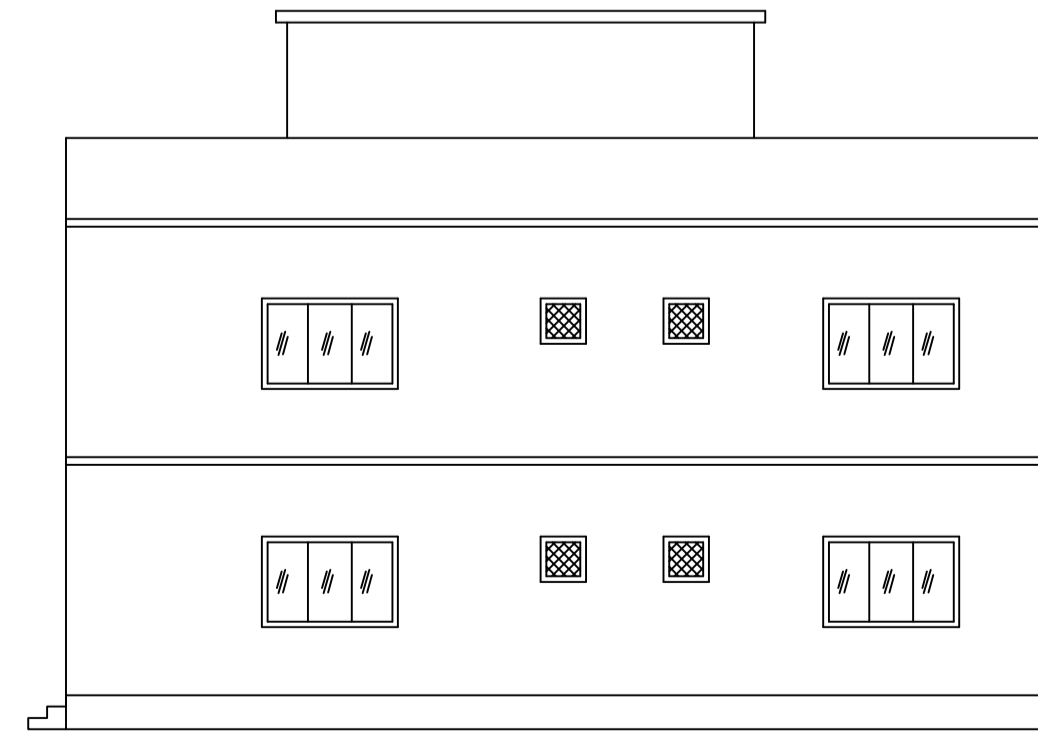
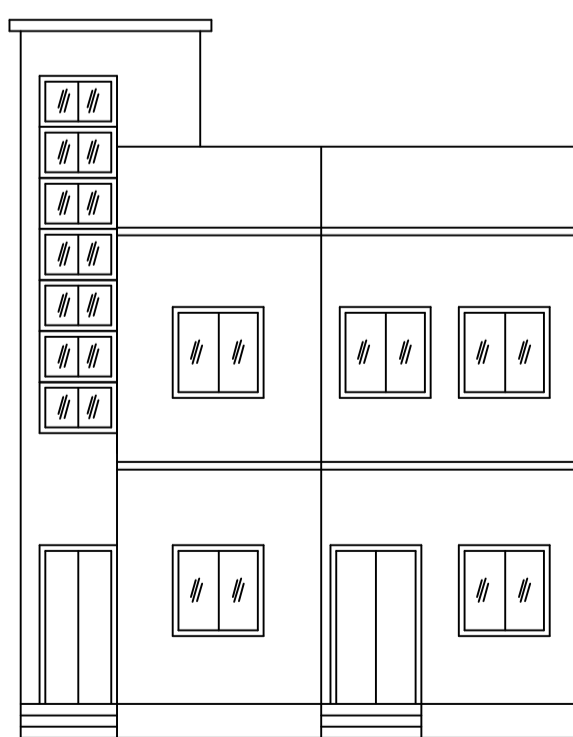

DETAIL OF COLUMNS

LTP NAME AND SIGNATURE	STRUCTURAL ENG'S NAME AND SIGNATURE	BUILDER NAME AND SIGNATURE	DIGITAL SIGNATURE
AMARENDRA KUMAR MADA/ENG/0008/2019			