

Proposal Basic Information	
Proposal File No.	MADA/BP/0127/2020
Owner Name	RAJESH KUMAR PANDIT
Khata No	OLD - 40 (NEW- 121)
Plot No	OLD - 760 , NEW - 1008
Village Name	Nawadhi
Use	Residential
SubUse	Bungalow/ Dwelling / Non Apartment

AREA STATEMENT MINERAL AREA DEVELOPMENT AUTHORITY		VERSION NO. : 1.0.53
PROJECT DETAIL:		VERSION DATE: 16/10/2020
Region: JHARKHAND URBAN LOCAL BODIES	Plot Use: Residential	
District: DHANBAD	Plot SubUse: Bungalow/ Dwelling / Non Apartment	
Authority: MINERAL AREA DEVELOPMENT AUTHORITY	PlotNearby/ReligiousStructure: NA	
Inward No: MADA/BP/0127/2020	Plot/SubPlot No: OLD - 760 , NEW - 1008	
Application Type: General Proposal	North: Plot No. - PARMILA DEVI	
Project Type: Building Permission	South: Plot No. - MOHAN PANDIT	
Nature of Development: New	East: Plot No. - 761	
Location of Development Area: Old Area	West: Road Width - 6.09	
AREA DETAILS:		SQ.MT.
AREA OF PLOT (Minimum)	(A)	161.16
NET AREA OF PLOT(Gross Plot Area - Deduction from Gross Plot area)	(A-Deductions)	161.16
Deduction for Balance Plot Area(from Gross Plot Area)		
Common Plot		28.62
Total		28.62
BALANCE AREA OF PLOT(Net Plot Area - Recreational/Amenity space)	(A-Deductions)	132.54
PLOT AREA FOR COVERAGE(Net Plot Area)	(A-Deductions)	161.16
Plot Area for FAR (Net Plot Area + Road/Widening Area)	(A-Deductions)	161.16
COVERAGE CHECK		
Permissible Coverage area ( 70.00 % )		112.81
Proposed Coverage Area ( 64.17 % )		103.42
Total Prop. Coverage Area ( 64.17 % )		103.42
Balance coverage area ( 5.83 % )		9.39
FAR CHECK		
Perm. FAR Area ( 2.50 )		402.90
Total Perm. FAR area		402.90
Residential FAR		206.84
Proposed FAR Area		206.84
Total Proposed FAR Area		206.84
Consumed FAR (Factor)		1.28
Balance FAR Area		196.06
BUILT UP AREA CHECK		
Total Proposed BuiltUp Area		206.84
ARCHITECT (Regd)		KUSHJEE PANDEY
ENGINEER (Regd)		
SUPERVISOR (Regd)		
OWNER (Regd)		RAJESH KUMAR PANDIT
DEVELOPMENT AUTHORITY		LOCAL BODY

COLOR INDEX	
PLOT BOUNDARY	Black
ABUTTING ROAD	Red
PROPOSED CONSTRUCTION	Green
COMMON PLOT	Yellow
ROAD WIDENING AREA	Blue
EXISTING (To be retained)	Orange
EXISTING (To be demolished)	Grey

SCHEDULE OF DOOR:

BUILDING NAME	NAME	LENGTH	HEIGHT	NOS
A (BUILDING)	D2	0.76	2.10	04
A (BUILDING)	D1	0.91	2.10	10
A (BUILDING)	D	0.98	2.10	02

SCHEDULE OF WINDOW/VENTILATION:

BUILDING NAME	NAME	LENGTH	HEIGHT	NOS
A (BUILDING)	V	0.76	1.20	04
A (BUILDING)	W2	1.39	1.20	02
A (BUILDING)	W	1.83	1.20	15
A (BUILDING)	W1	2.80	1.20	03

FAR & Tenement Details (Table 4c-1)

Building	No. of Same Bldg	Total Built Up Area (Sq.mt.)	Proposed FAR Area (Sq.mt.)	Total FAR Area (Sq.mt.)	Total Consumed Additional FAR Area (Sq.mt.)	Trmt (No.)
A (BUILDING)	1	206.84	206.84	206.84	206.84	01
Grand Total :	1	206.84	206.84	206.84	206.84	01

UnitBUA Table for Building :A (BUILDING)

FLOOR	Name	UnitBUA Type	UnitBUA Area	Carpet Area	No. of Rooms	No. of Tenement
GROUND FLOOR PLAN	SPLIT FLAT - A	FLAT	187.54	187.22	8	1
FIRST FLOOR PLAN	SPLIT FLAT - A	FLAT	0.00	0.00	8	0
Total:	-	-	187.54	187.22	16	1

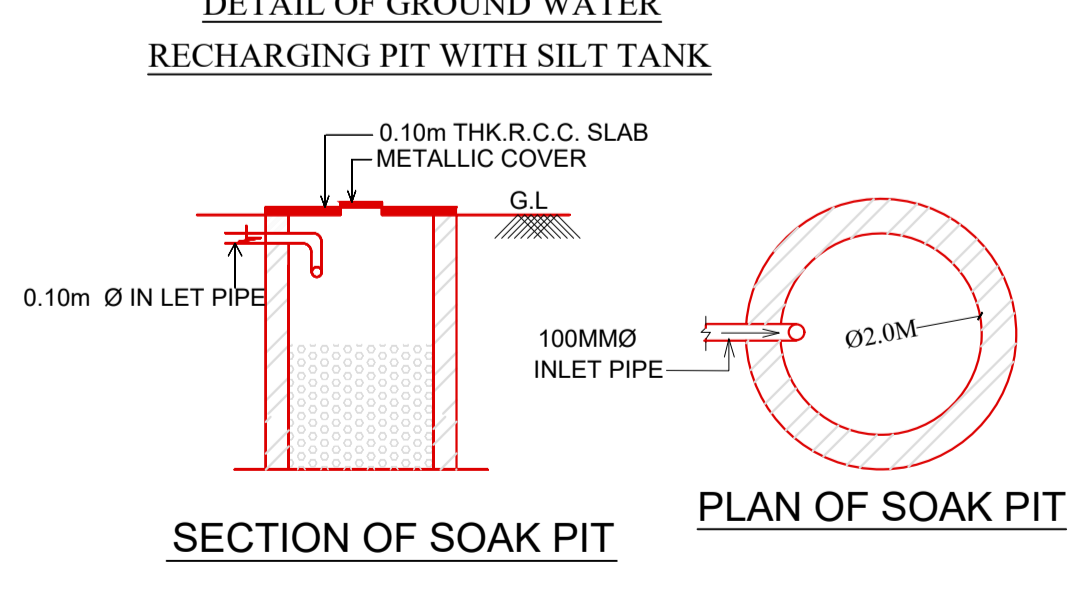
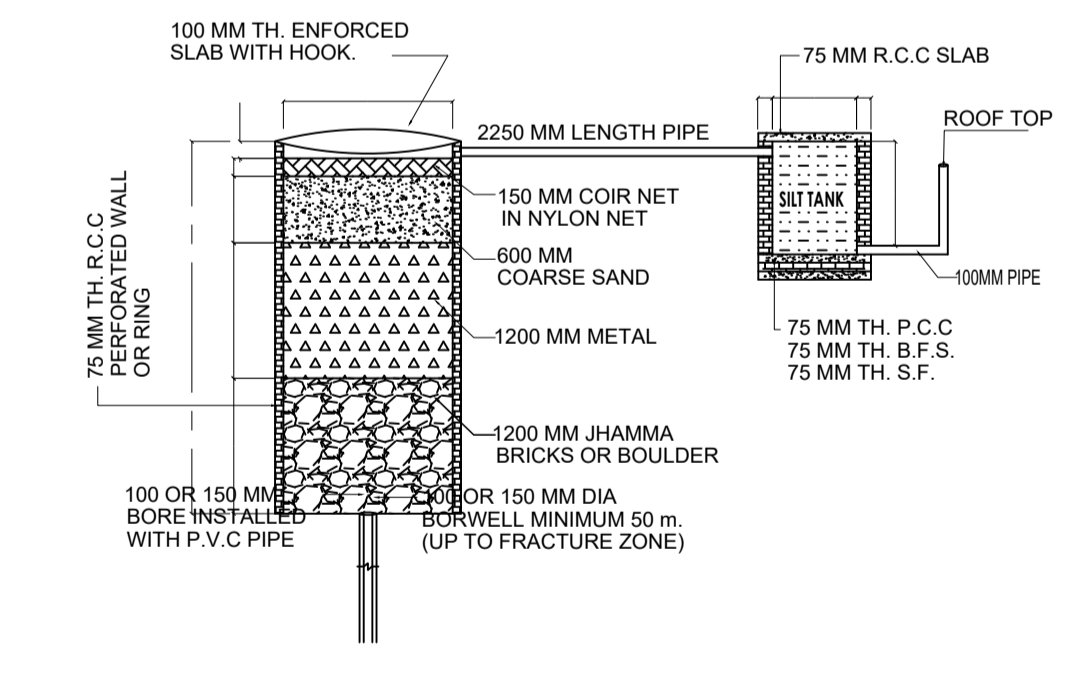
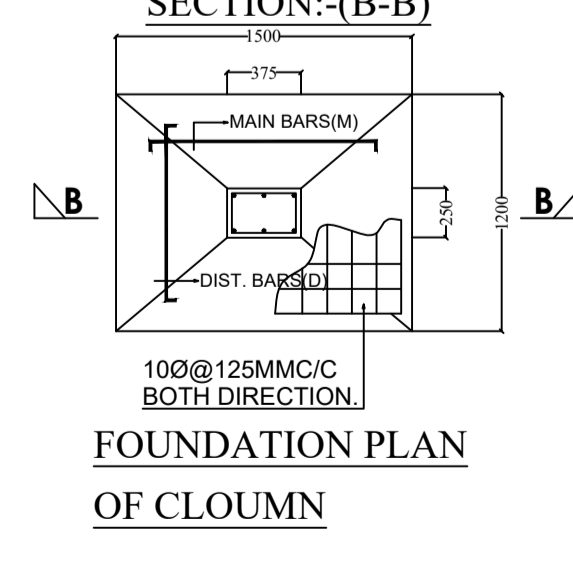
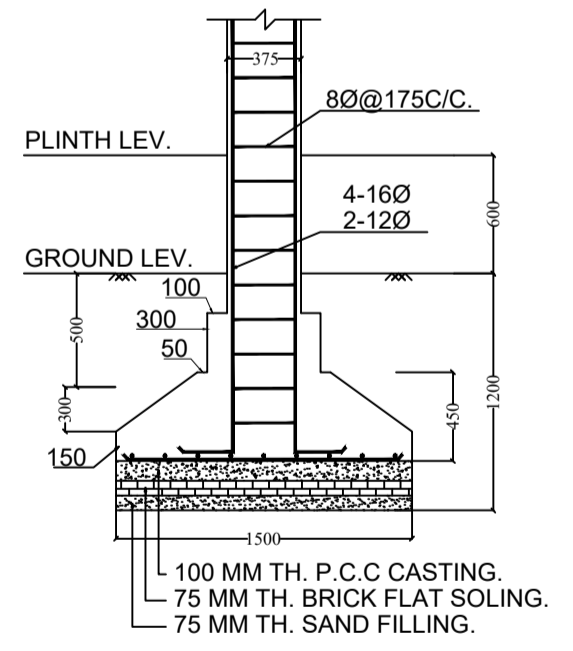
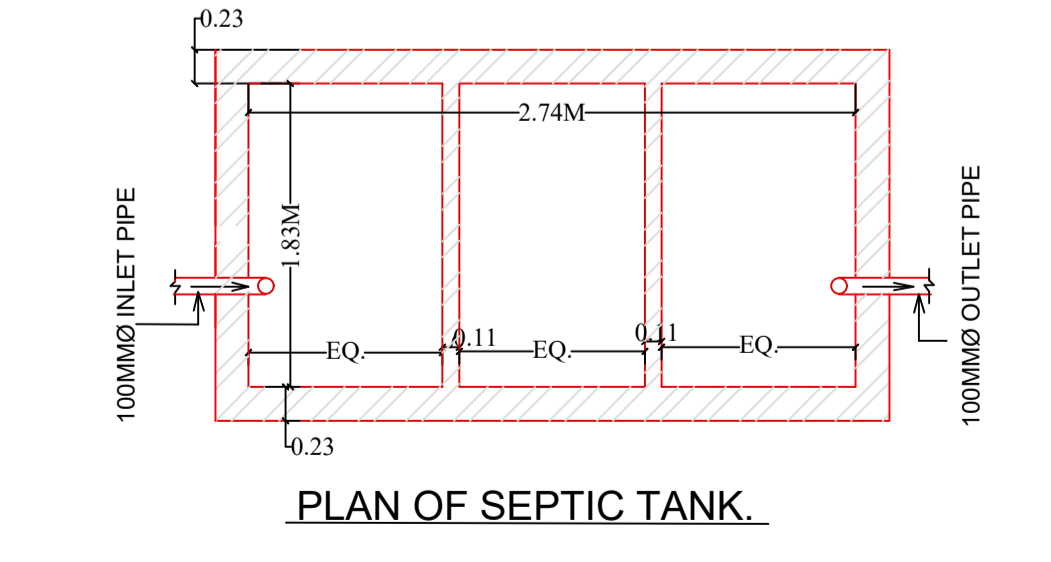
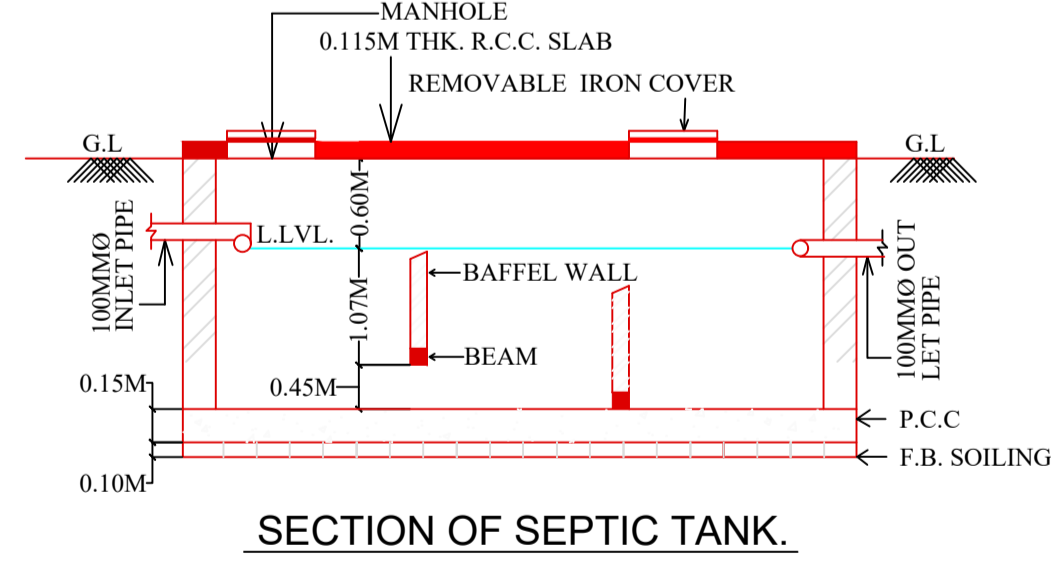

Floor Name	A (BUILDING)		Total	
	Proposed Built Up Area (Sq.mt.)	Proposed FAR Area (Sq.mt.)	Total Proposed Built Up Area (Sq.mt.)	Total FAR Area (Sq.mt.)
Ground Floor	103.42	103.42	103.42	103.42
First Floor	103.42	103.42	103.42	103.42
Terrace Floor	0.00	0.00	0.00	0.00
Total :	206.84	206.84	206.84	206.84

Building Name	Building Use	Building SubUse	Building Structure
A (BUILDING)	Residential	Bungalow/ Dwelling / Non Apartment	Non-Highrise

Building :A (BUILDING)					
Floor Name	Total Built Up Area (Sq.mt.)	Proposed FAR Area (Sq.mt.)	Total FAR Area (Sq.mt.)	Total Consumed Additional FAR Area (Sq.mt.)	Trmt (No.)
Ground Floor	103.42	103.42	103.42	103.42	01
First Floor	103.42	103.42	103.42	103.42	00
Terrace Floor	0.00	0.00	0.00	0.00	00
Total :	206.84	206.84	206.84	206.84	01
Total Number of Same Buildings :	1				
Total :	206.84	206.84	206.84	206.84	01

LTP NAME AND SIGNATURE	STRUCTURAL ENG'S NAME AND SIGNATURE	BUILDER NAME AND SIGNATURE	DIGITAL SIGNATURE
KUSHJEE PANDEY MADA/ARC/0027/2019			



Proposal Basic Information	
Proposal File No.	MADA/BP/0127/2020
Owner Name	RAJESH KUMAR PANDIT
Khata No	OLD - 40 (NEW- 121)
Plot No	OLD - 760 , NEW - 1008
Village Name	Nawadhi
Use	Residential
SubUse	Bungalow/ Dwelling / Non Apartment

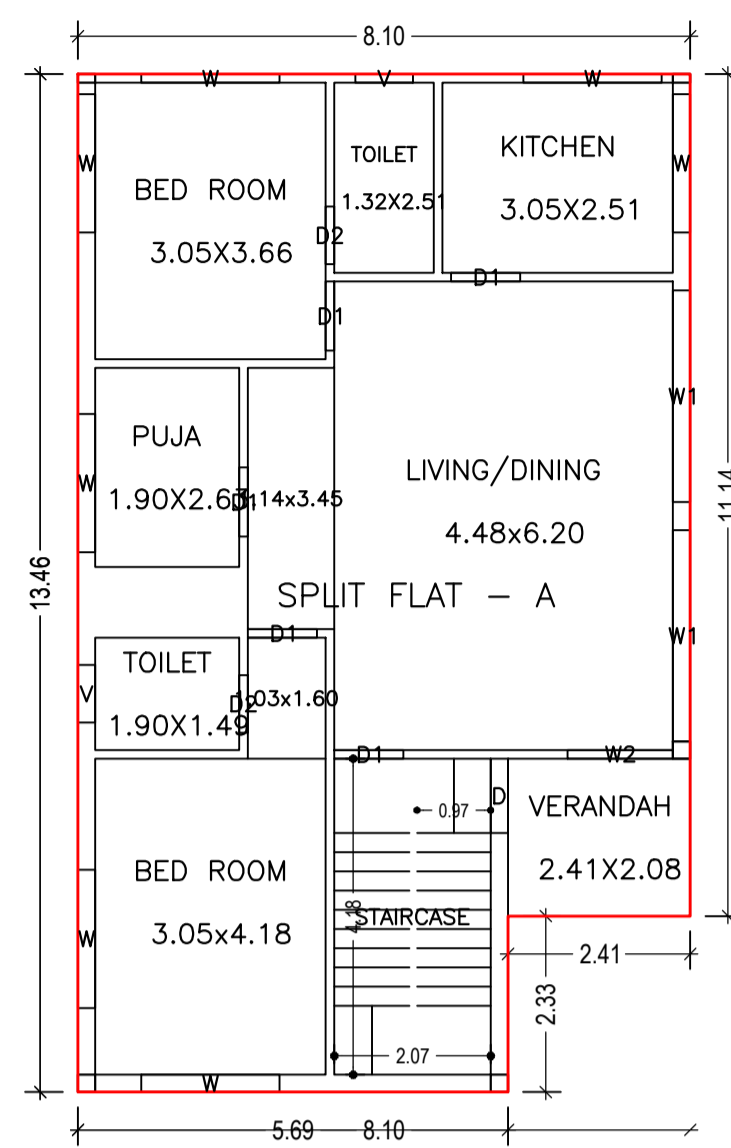
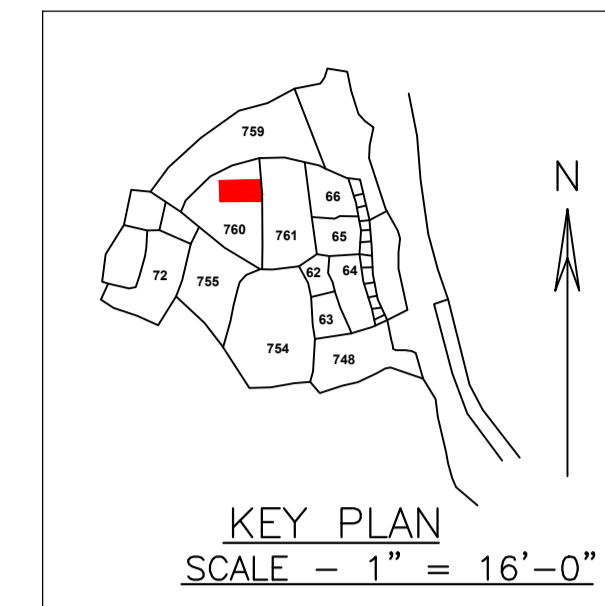

GROUND FLOOR PLAN  
(Proposed)  
(SCALE 1:100)

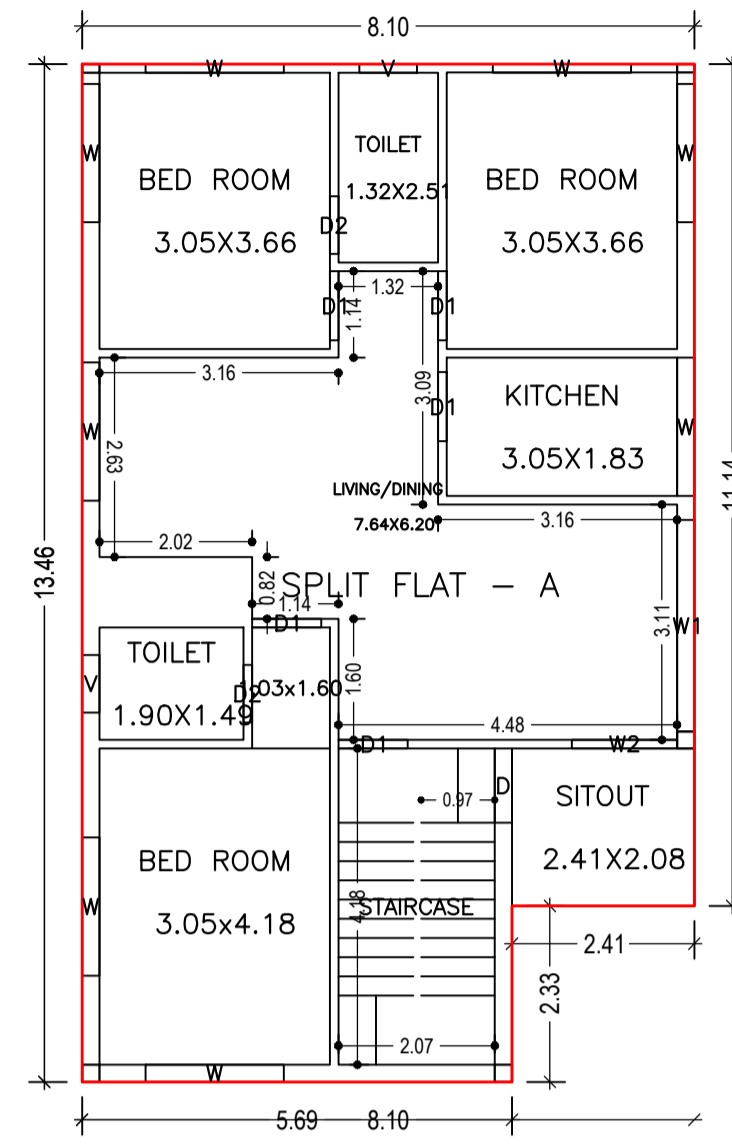

FIRST FLOOR PLAN  
(Proposed)  
(SCALE 1:100)

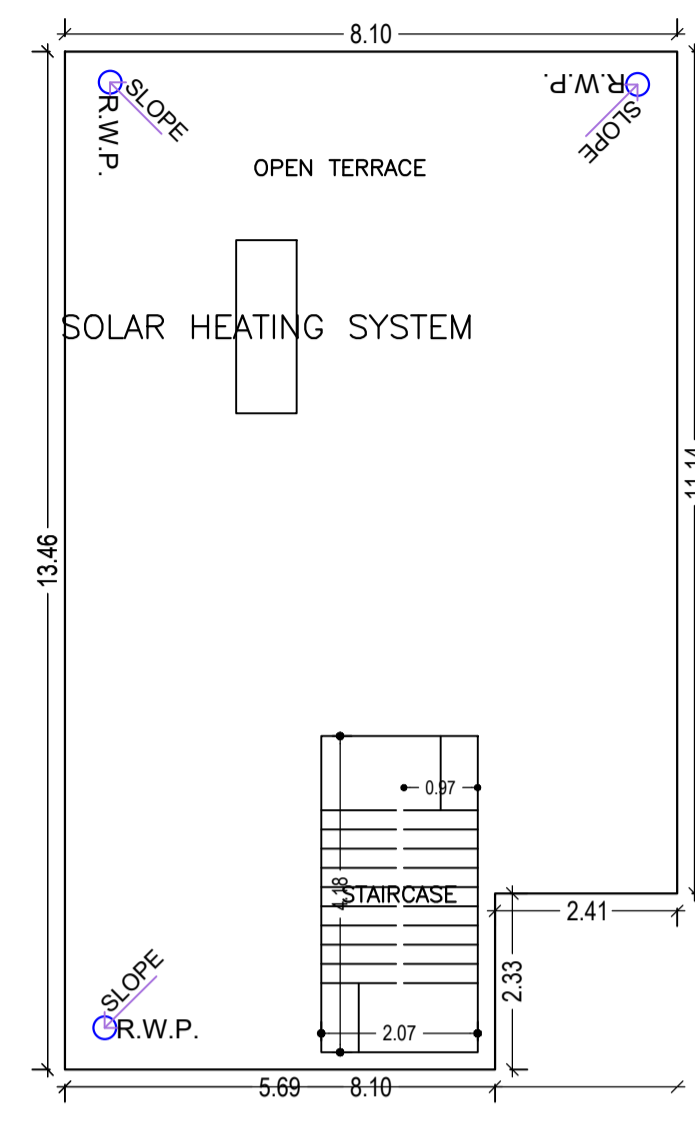

TERRACE FLOOR PLAN  
(SCALE 1:100)

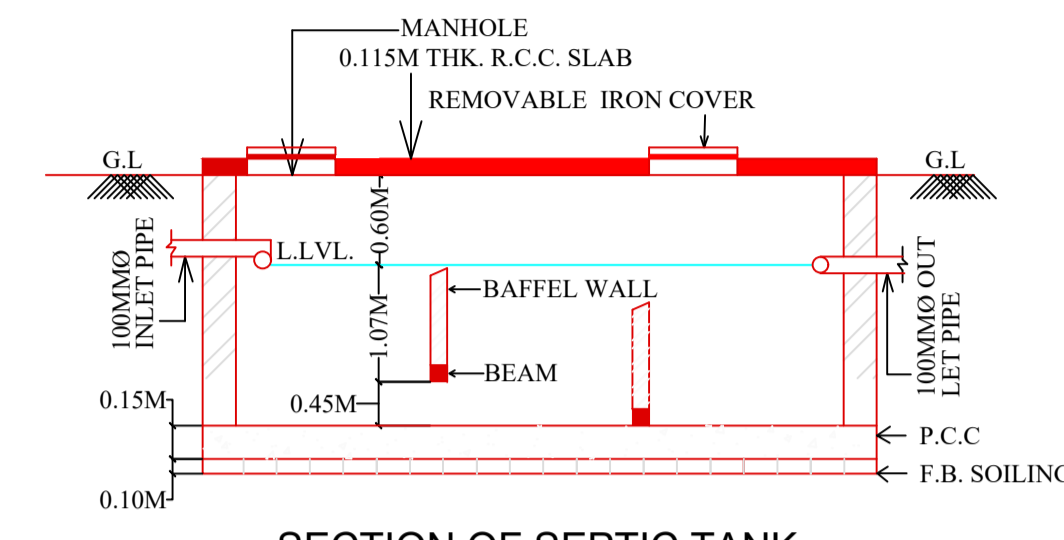

SECTION OF SEPTIC TANK.

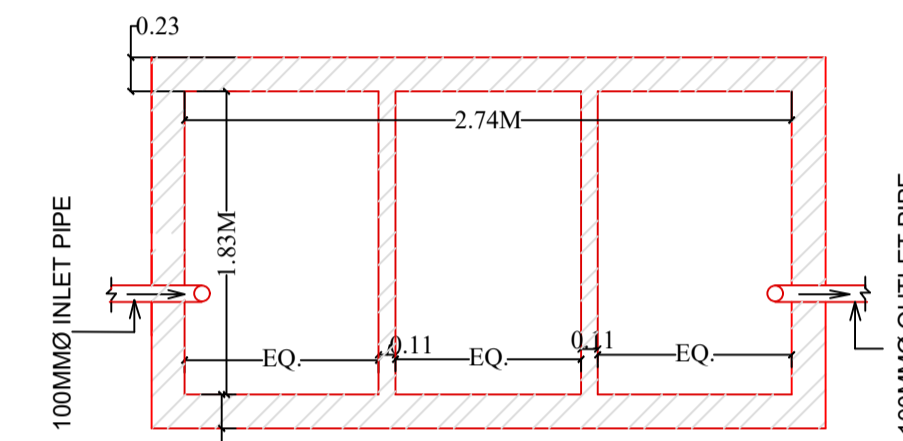

PLAN OF SEPTIC TANK.

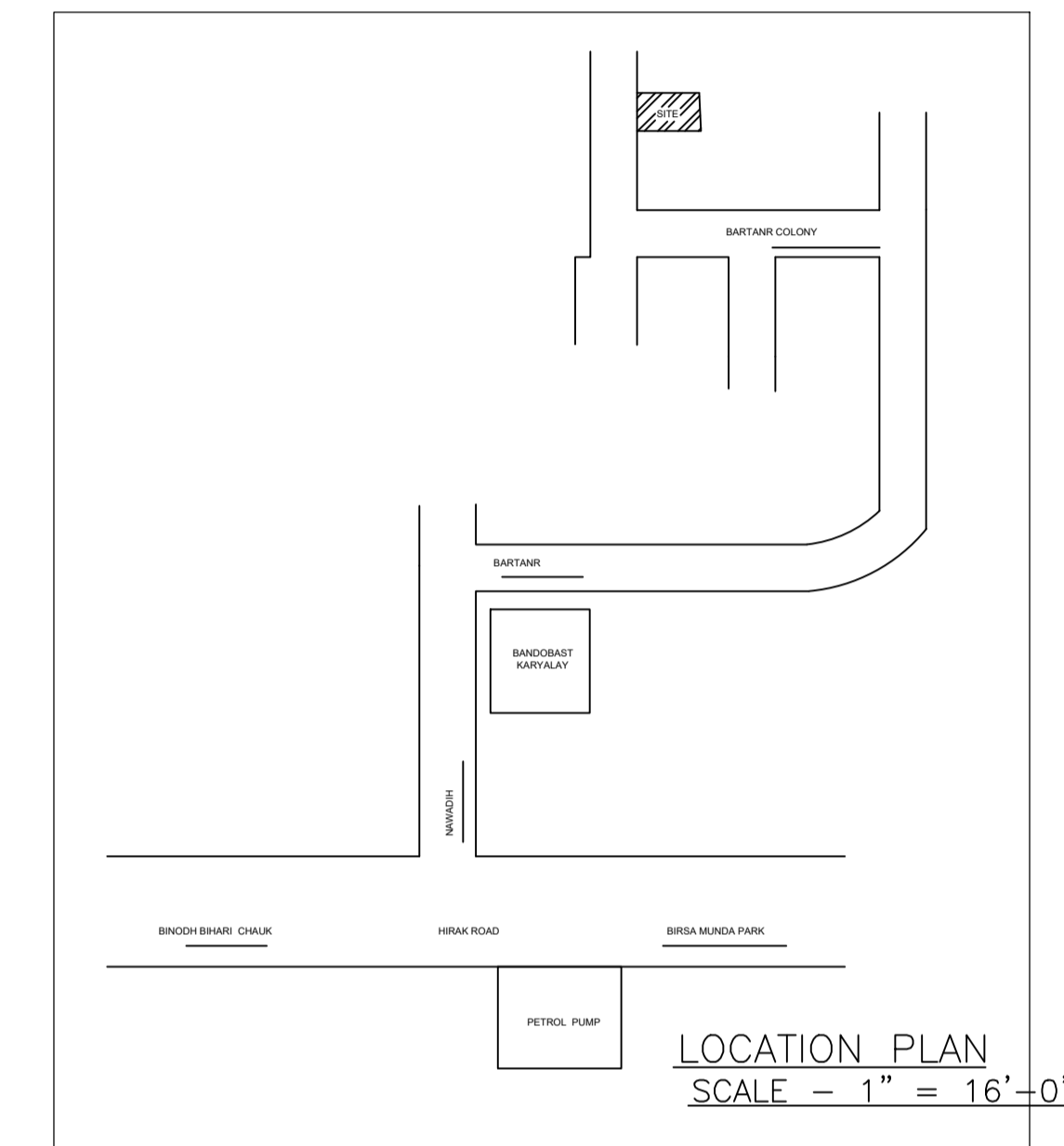

LOCATION PLAN  
(SCALE 1" = 16'-0")

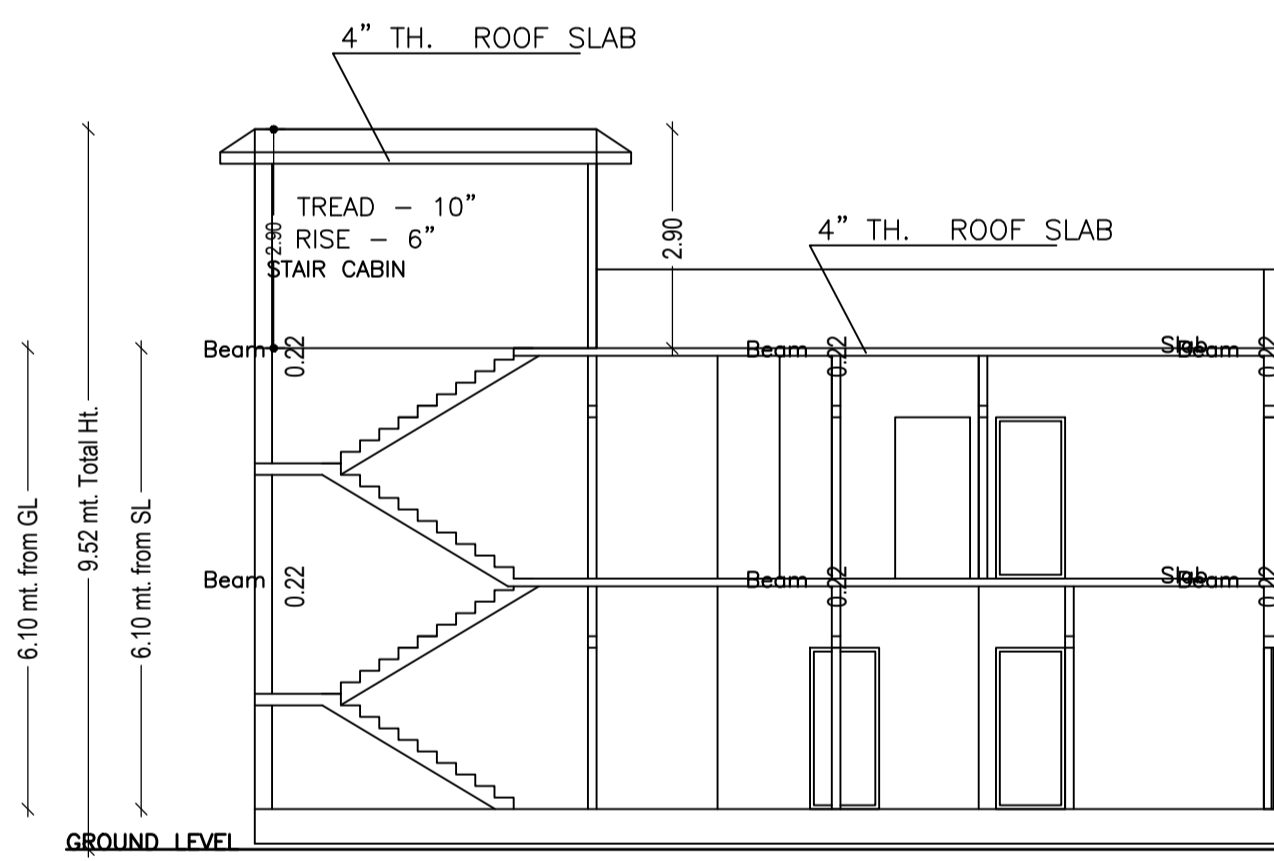

SECTION Y-Y

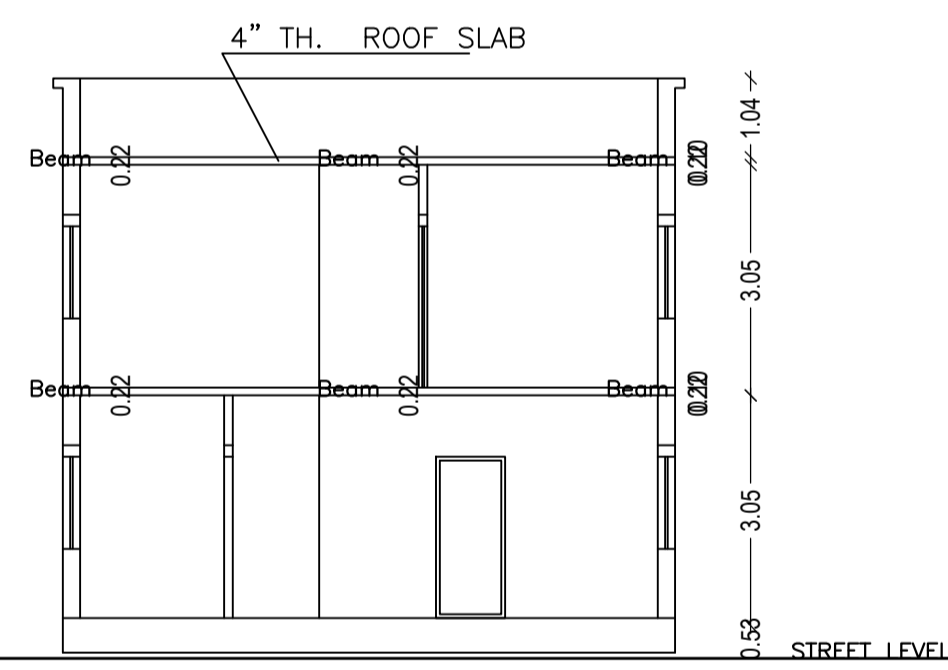

SECTION X-X

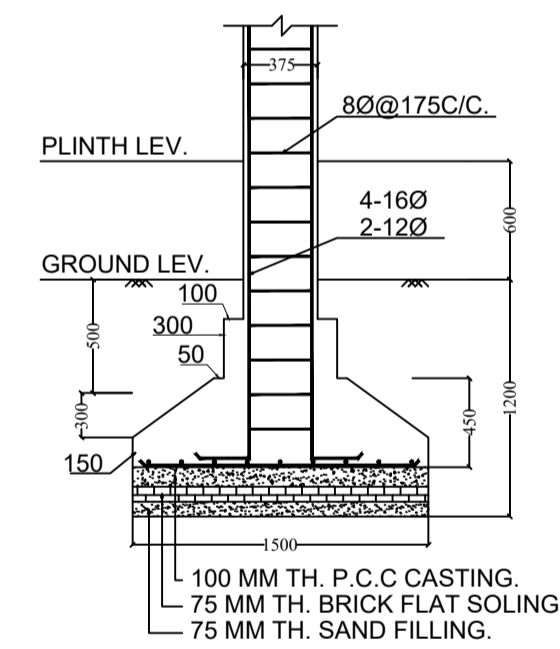

SECTION -(B-B)

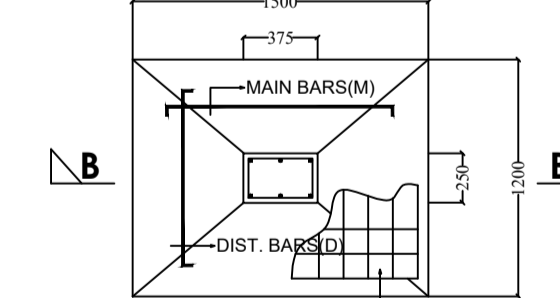

FOUNDATION PLAN  
OF COLUMN

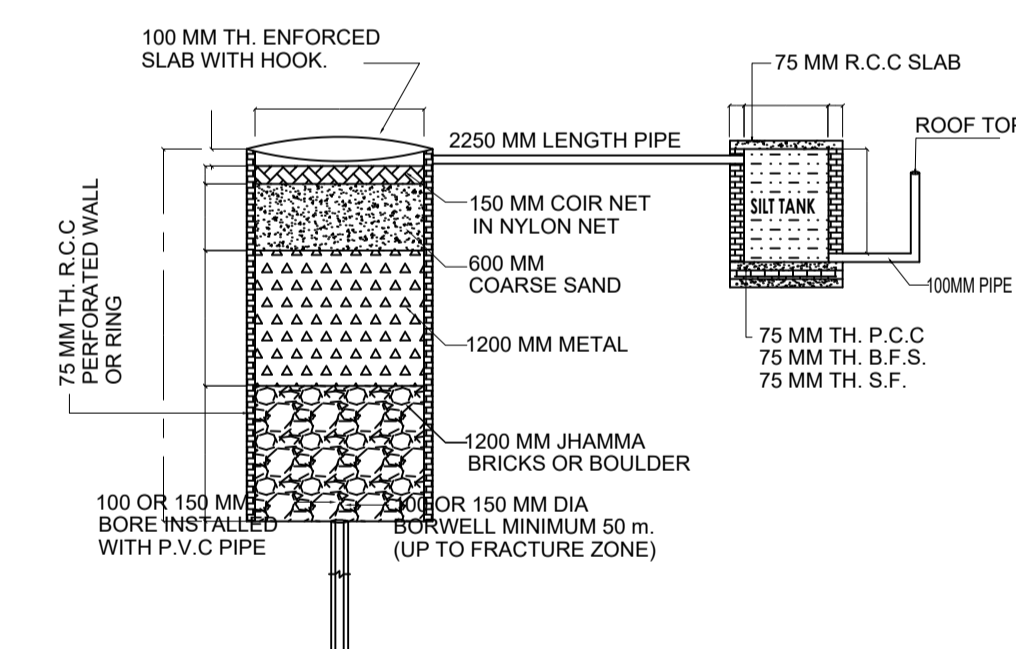

DETAIL OF GROUND WATER  
RECHARGING PIT WITH SILT TANK

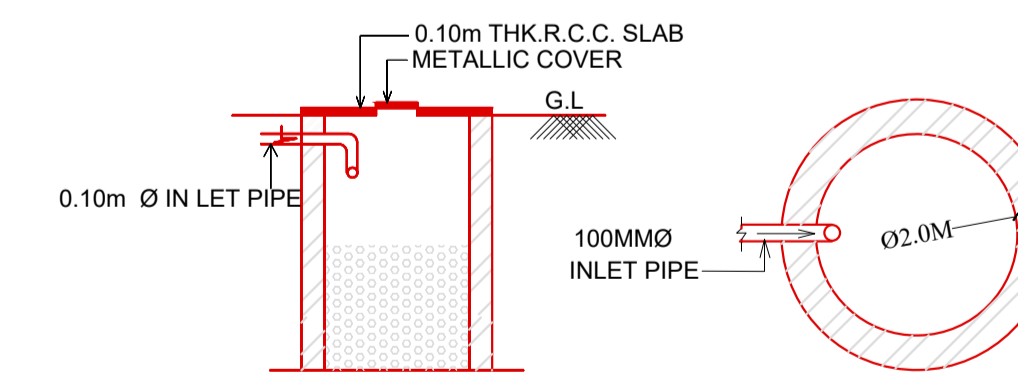

SECTION OF SOAK PIT

PLAN OF SOAK PIT

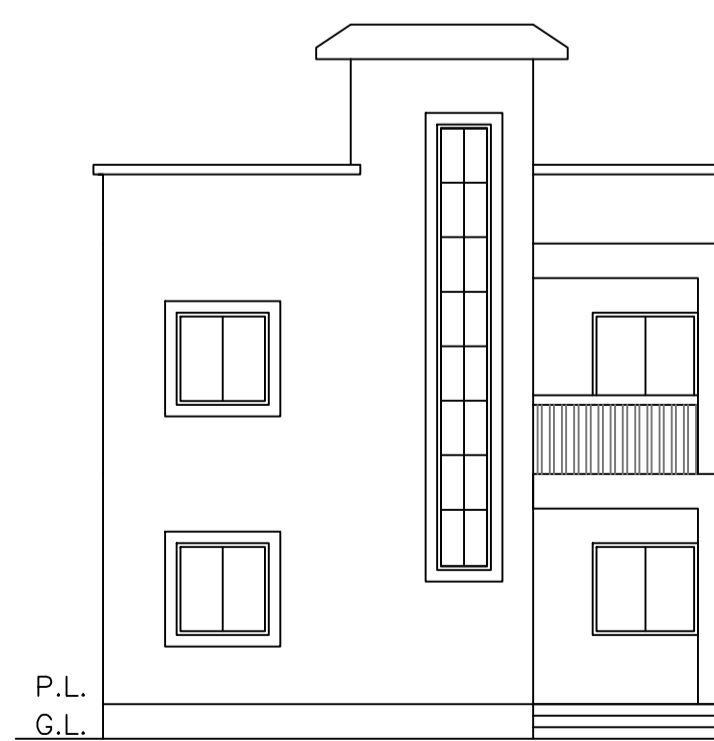

FRONT ELEVATION

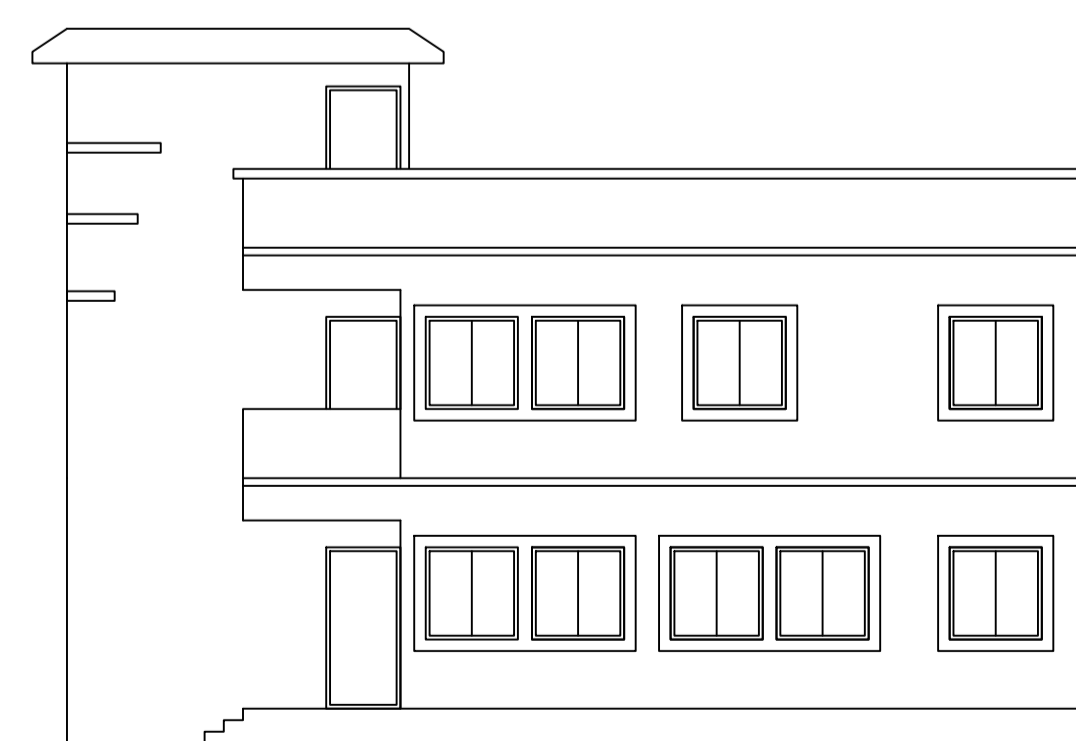

RIGHT SIDE ELEVATION

LTP NAME AND SIGNATURE	STRUCTURAL ENG'S NAME AND SIGNATURE	BUILDER NAME AND SIGNATURE	DIGITAL SIGNATURE
KUSHJEE PANDEY MADA/ARC/0027/2019			