

STRUCTURAL DESIGN SAFETY DETAILS

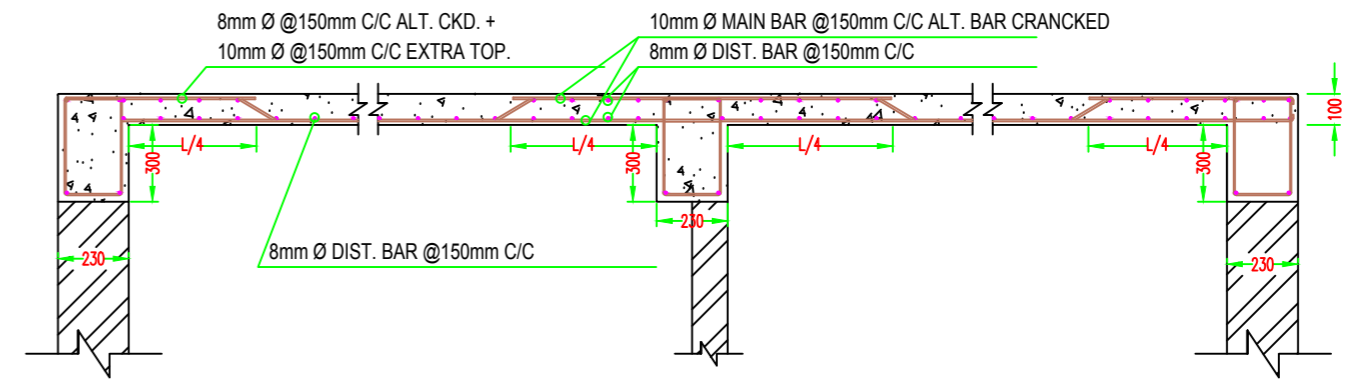

TYPICAL DETAIL OF RCC ROOF SLAB

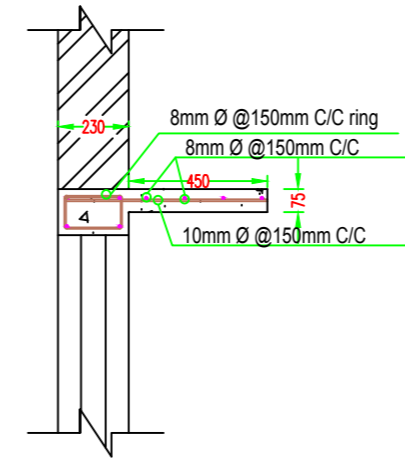

DET. OF R.C.C. CHAJJA

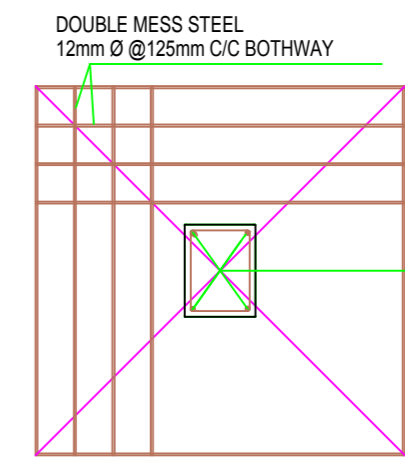

VERTICAL : AS PER COLUMN TABLE
RING : 8Ø @ 6" C/C
1/2/3 SETS AS REQD.

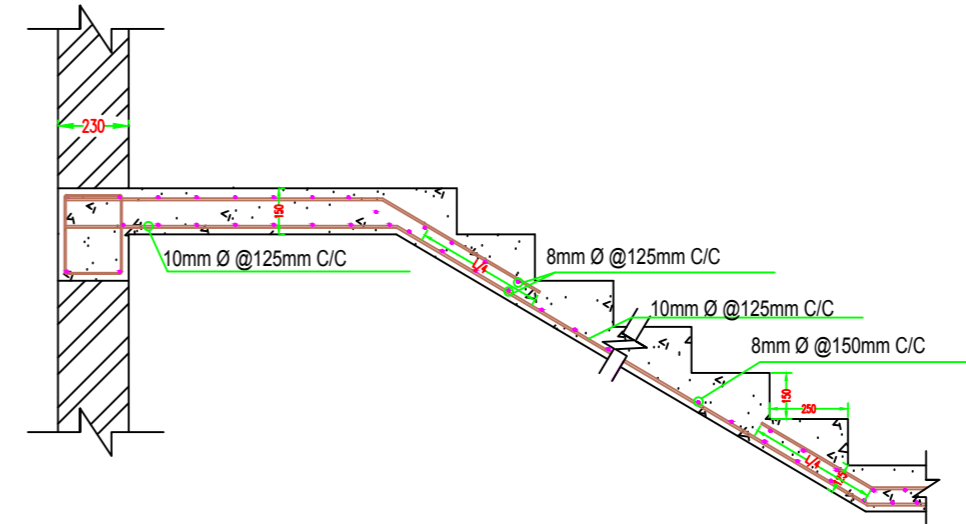

TYPICAL DETAIL OF RCC STAIR

SCHEDULE OF COLUMN & FOUNDATION														
SN	ITEMS	SYM	SIZE	FOUNDATION EXCAVATION SIZE L X B X D	SECTION	REINFORCEMENT VERTICAL RING	COVER	RCC FOUNDATION						REMARKS
								L1	B1	D1	D2	D3	L2	
1.	COLUMN	C1	250X300	1700X1700X2000		8NOS-16Ø 8Ø @ 6" C/C	1.5"	1500	1500	200	600	900	100	RCC MIX: M20
2.	COLUMN	C2	250X380	1700X2000X2000		8NOS-16Ø 8Ø @ 6" C/C (2 SETS)	1.5"	1500	1800	250	600	850	100	RCC MIX: M20
3.	COLUMN	C3	250X450	1700X2000X2000		10NOS-16Ø 8Ø @ 6" C/C (2 SETS)	1.5"	1500	1800	250	600	850	150	RCC MIX: M20
4.	COLUMN	C4	250X600	2000X2600X2000		10NOS-20Ø 8Ø @ 6" C/C (4 SETS)	1.5"	1800	2400	450	600	650	150	RCC MIX: M20
5.	COLUMN	C5	350X600	1800X2600X2000		12NOS-20Ø 4NOS-16Ø (3 SETS) (1 LINC)	1.5"	1600	2400	450	600	650	150	RCC MIX: M20

SCHEDULE OF COLUMN

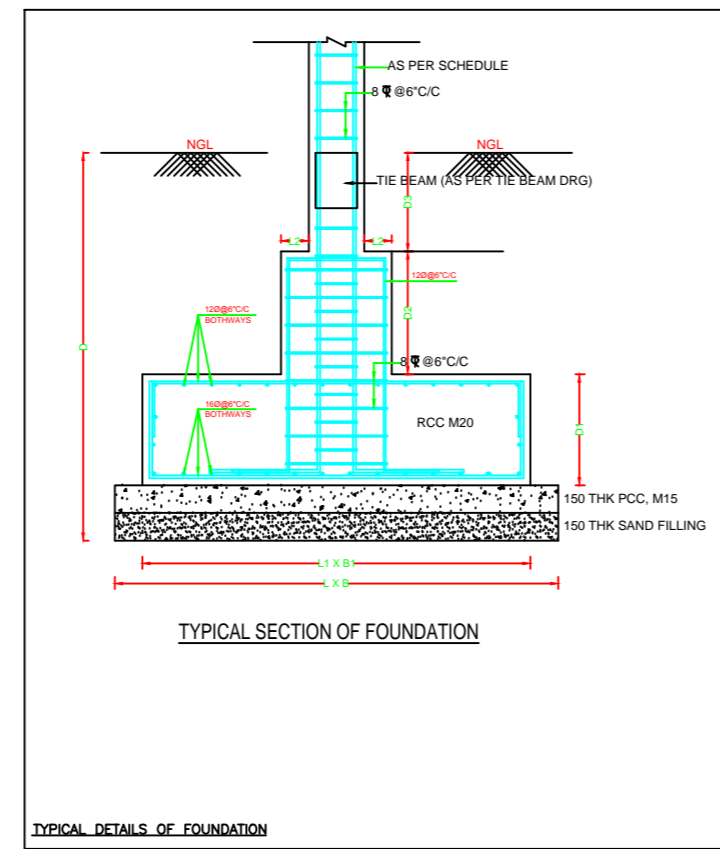

TYPICAL SECTION OF FOUNDATION

TYPICAL DETAILS OF FOUNDATION

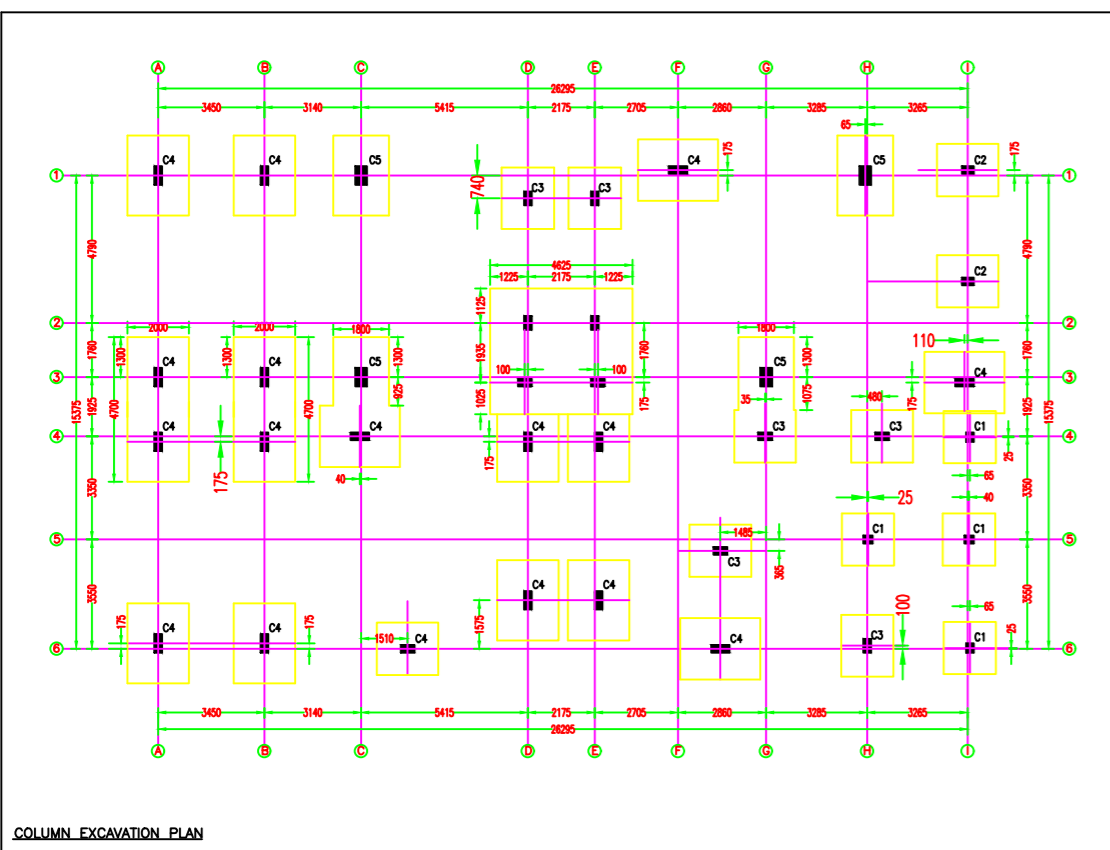

COLUMN EXCAVATION PLAN

DRAWING OF PROPOSED STRUCTURAL DETAILS OF RESIDENTIAL BUILDING OF 1. SMT. SHRADHA AGARWAL W/O SRI DEEPAK AGARWAL & 2. UMA DEVI AGARWAL, W/O LATE BASUDEO AGARWAL, THROUGH ITS POWER OF ATTORNEY M/S KHARKIA DEVELOPERS PRIVATE LIMITED REPRESENTED THROUGH ONE OF ITS DIRECTOR SRI DEEPAK AGARWAL UNDER MOUZA MERAH, NO. 251, KHATA NO. 125, PLOT NO. 514(P) & KHATA NO. 68, PLOT NO. 512(P) UNDER P.S. MATHON, DIST. DHANBAD IN THE STATE OF JHARKHAND