

FAR & Tenement Details (Table 4c-1)

Building	No. of Same Bldg	Total Built Up Area (Sq.mt.)	Deductions (Area in Sq.mt.)	Proposed FAR Area (Sq.mt.)	Total FAR Area (Sq.mt.)	Total Consumed Additional FAR Area (Sq.mt.)	Tnmt (No.)
			Accessory Use	Archi.Proj.	Resi.		
A (REKHA SINGH)	1	277.78	4.23	13.50	260.05	260.05	01
Grand Total:	1	277.78	4.23	13.50	260.05	260.05	01

Proposal Basic Information

Proposal File No.	MADA/EP/0015/2020
Owner Name	Smt. Rekha Singh
Khata No	01, New Khata No - 19
Plot No	592 & 596, New Plot No - 696
Village Name	Sabalpur
Use	Residential
SubUse	Bungalow/ Dwelling / Non Apartment

AREA STATEMENT MINERAL AREA DEVELOPMENT AUTHORITY

VERSION NO.: 1.0.46
VERSION DATE: 22/06/2020

AREA DETAILS:		SQ.MT.
AREA OF PLOT (Minimum)	(A)	266.38
NET AREA OF PLOT (Gross Plot Area - Deduction from Gross Plot area)	(A-Deductions)	266.38
Deduction for Balance Plot Area (from Gross Plot Area)		
Common Plot		20.95
Total		20.95
BALANCE AREA OF PLOT (Net Plot Area - Recreational/Amenity space)	(A-Deductions)	245.43
PLOT AREA FOR COVERAGE (Net Plot Area)	(A-Deductions)	266.38
Plot Area for FAR (Net Plot Area + Road Widening Area)	(A-Deductions)	266.38
COVERAGE CHECK		
Permissible Coverage area (60.00 %)		159.83
Proposed Coverage Area (47.58 %)		126.75
Total Prop. Coverage Area (47.58 %)		126.75
Balance coverage area (12.42 %)		33.08
FAR CHECK		
Perm. FAR Area (1.80)		479.48
Total Perm. FAR area		479.48
Residential FAR		260.06
Proposed FAR Area		260.06
Total Proposed FAR Area		260.06
Consumed FAR (Factor)		0.98
Balance FAR Area		219.42
BUILT UP AREA CHECK		
Total Proposed BuiltUp Area		277.78
ARCHITECT (Regd)		Piyush Kanti Singh
ENGINEER (Regd)		
SUPERVISOR (Regd)		
OWNER (Regd)		Smt. Rekha Singh
DEVELOPMENT AUTHORITY		LOCAL BODY

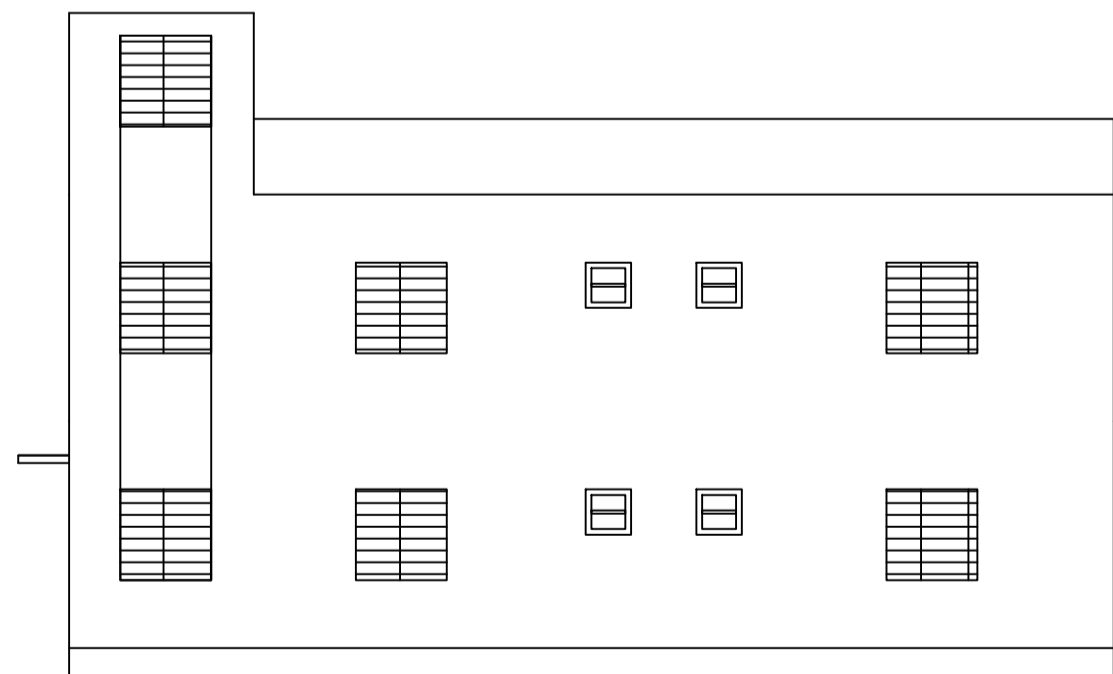
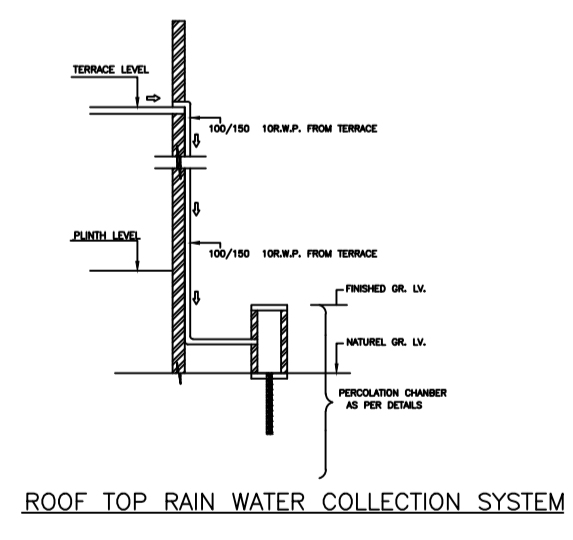
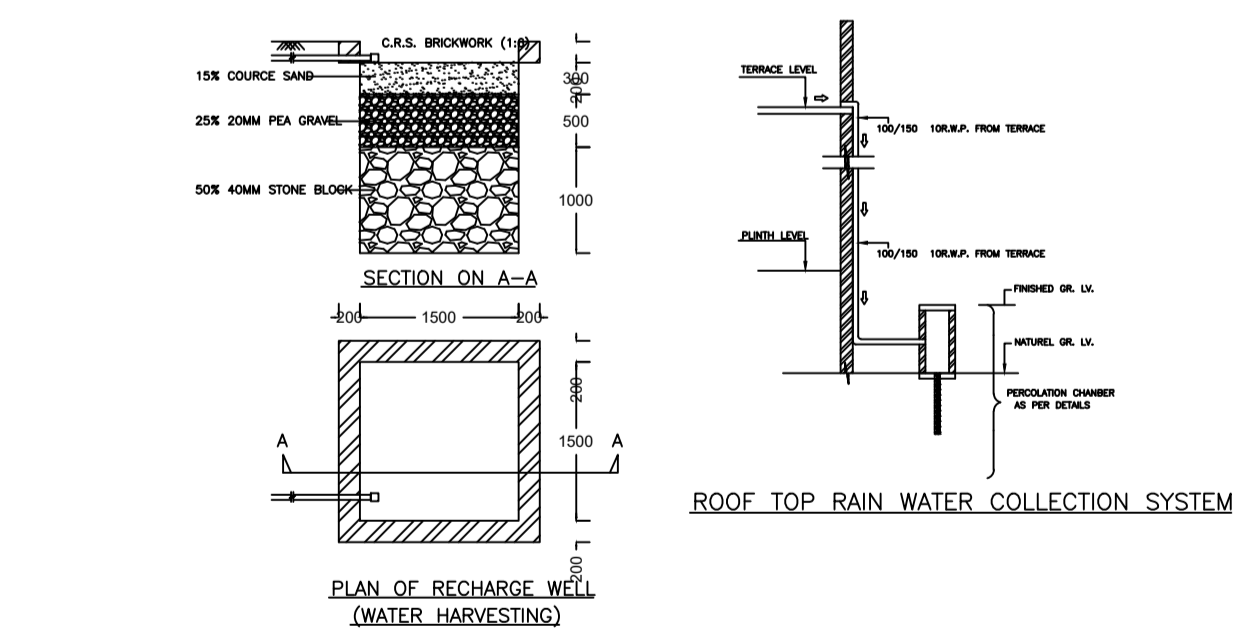
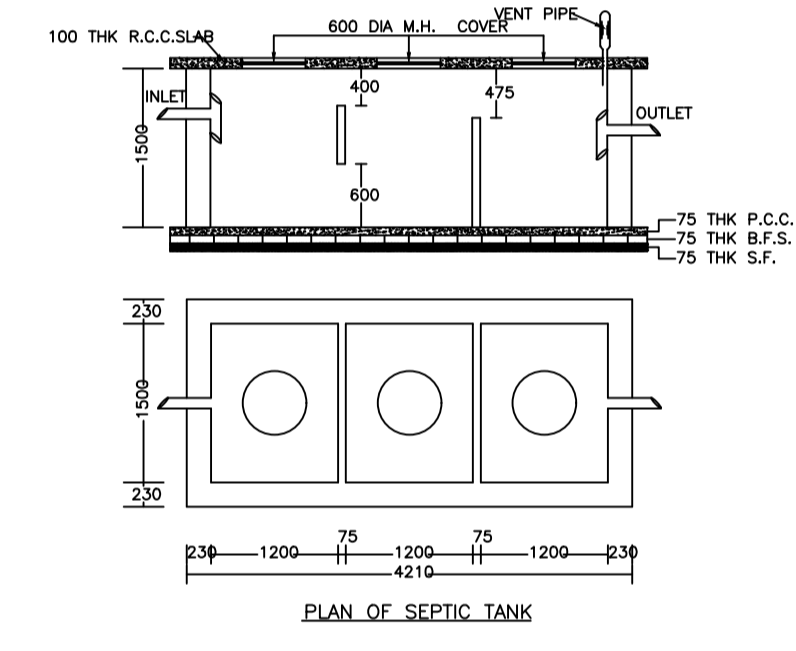
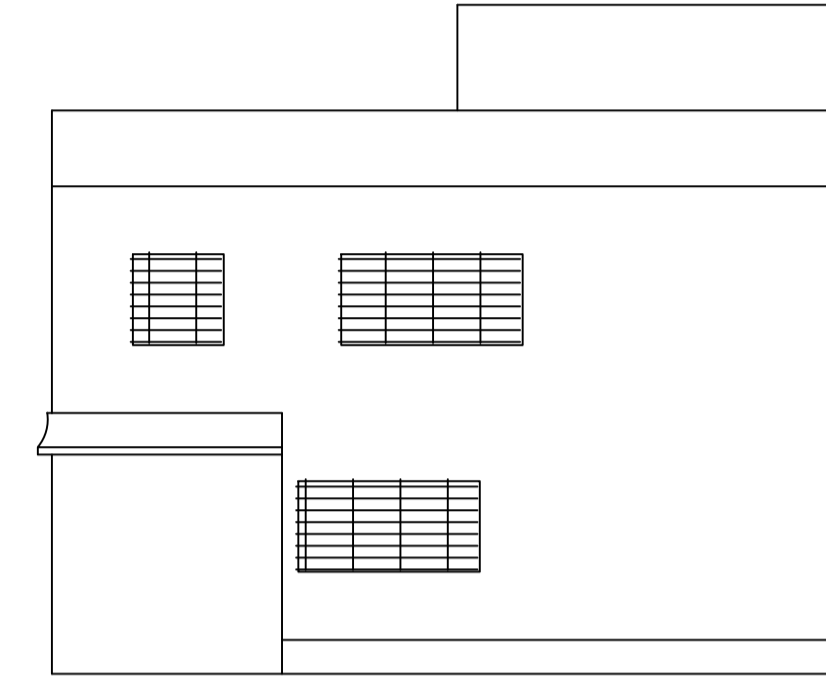

Building :A (REKHA SINGH)

Floor Name	Total Built Up Area (Sq.mt.)	Deductions (Area in Sq.mt.)		Proposed FAR Area (Sq.mt.)	Total FAR Area (Sq.mt.)	Total Consumed Additional FAR Area (Sq.mt.)	Tnmt (No.)
		Accessory Use	Archi.Proj.				
Ground Floor	140.25	0.00	13.50	126.75	126.75	126.75	01
First Floor	137.53	4.23	0.00	133.30	133.30	133.30	00
Terrace Floor	0.00	0.00	0.00	0.00	0.00	0.00	00
Total :	277.78	4.23	13.50	260.05	260.05	260.05	01
Total Number of Same Buildings	1						
Total :	277.78	4.23	13.50	260.05	260.05	260.05	01

SCHEDULE OF DOOR:

BUILDING NAME	NAME	LENGTH	HEIGHT	NOS
A (REKHA SINGH)	D2	0.75	2.10	05
A (REKHA SINGH)	D1	0.90	2.10	03
A (REKHA SINGH)	D	1.00	2.10	10

SCHEDULE OF WINDOW/VENTILATION:

BUILDING NAME	NAME	LENGTH	HEIGHT	NOS
A (REKHA SINGH)	V	0.60	0.60	05
A (REKHA SINGH)	W1	0.90	1.20	03
A (REKHA SINGH)	W	1.20	1.20	18

UnitBUA Table for Building :A (REKHA SINGH)

FLOOR	Name	UnitBUA Type	UnitBUA Area	Carpet Area	No. of Rooms	No. of Tenement
GROUND FLOOR PLAN	SPLIT 1	FLAT	264.29	264.09	8	1
FIRST FLOOR PLAN	SPLIT 1	FLAT	0.00	0.00	10	0
Total:	-	-	264.29	264.09	18	1

LTP NAME AND SIGNATURE	STRUCTURAL ENG'S NAME AND SIGNATURE	BUILDER NAME AND SIGNATURE	DIGITAL SIGNATURE
Piyush Kanti Singh MADA/ENG/0012/2019			

