

SCHEDULE OF DOOR:

BUILDING NAME	NAME	LENGTH	HEIGHT	NOS
A (A)	D	0.90	2.10	08

SCHEDULE OF WINDOW/VENTILATION:

BUILDING NAME	NAME	LENGTH	HEIGHT	NOS
A (A)	W	1.36	1.20	02
A (A)	W	1.80	1.20	14

UnitBUA Table for Building :A (A)

FLOOR	Name	UnitBUA Type	UnitBUA Area	Carpet Area	No. of Rooms	No. of Tenement
GROUND FLOOR PLAN	SPLIT 1	FLAT	126.52	126.45	5	1
FIRST FLOOR PLAN	SPLIT 1	FLAT	0.00	0.00	5	0
Total:	-	-	126.52	126.45	10	1

FAR & Tenement Details (Table 4c-1)

Building	No. of Same Bldg	Total Built Up Area (Sq.mt.)	Proposed FAR Area (Sq.mt.) Resi.	Total FAR Area (Sq.mt.)	Total Consumed Additional FAR Area (Sq.mt.)	Tnmt (No.)
A (A)	1	126.52	126.52	126.52	126.52	01
Grand Total :	1	126.52	126.52	126.52	126.52	01

Proposal Basic Information

Proposal File No.	MADA/BP/0003/2020
Owner Name	JAIDEV BANERJEE
Khata No	OLD KHAT NO. 91, NEW - 12, 108
Plot No	OLD PLOT NO. 334, 329 (NEW PLOT NO. - 560, 563)
Village Name	Damodarpur
Use	Residential
SubUse	Bungalow/ Dwelling / Non Apartment

AREA STATEMENT MINERAL AREA DEVELOPMENT AUTHORITY

AREA DETAILS:	SQ.MT.
AREA OF PLOT (Minimum)	126.37
NET AREA OF PLOT(Gross Plot Area - Deduction from Gross Plot area)	126.37
Deduction for Balance Plot Area(from Gross Plot Area)	
Common Plot	17.49
Total	17.49
BALANCE AREA OF PLOT(Net Plot Area - Recreational/Amenity space)	108.88
PLOT AREA FOR COVERAGE(Net Plot Area)	126.37
Plot Area for FAR (Net Plot Area + Road Widening Area)	126.37
COVERAGE CHECK	
Permissible Coverage area (70.00 %)	88.46
Proposed Coverage Area (50.06 %)	63.26
Total Prop. Coverage Area (50.06 %)	63.26
Balance coverage area (19.94 %)	25.20
FAR CHECK	
Perm. FAR Area (1.50)	189.56
Total Perm. FAR area	189.56
Residential FAR	126.52
Proposed FAR Area	126.52
Total Proposed FAR Area	126.52
Consumed FAR (Factor)	1.00
Balance FAR Area	63.04
BUILT UP AREA CHECK	
Total Proposed BuiltUp Area	126.52
ARCHITECT (Regd)	MANOJ KUMAR SINGH
ENGINEER (Regd)	
SUPERVISOR (Regd)	
OWNER (Regd)	JAIDEV BANERJEE
DEVELOPMENT AUTHORITY	LOCAL BODY

COLOR INDEX

PLOT BOUNDARY	Black
ABUTTING ROAD	Green
PROPOSED CONSTRUCTION	Red
COMMON PLOT	Yellow
ROAD WIDENING AREA	Blue
EXISTING (To be retained)	Light Blue
EXISTING (To be demolished)	Dark Blue

Buildingwise Floor FAR Details

Floor Name	Building Name A (A)		Total	
	Proposed Built Up Area (Sq.mt.)	Proposed FAR Area (Sq.mt.)	Total Proposed Built Up Area (Sq.mt.)	Total FAR Area (Sq.mt.)
Ground Floor	63.26	63.26	63.26	63.26
First Floor	63.26	63.26	63.26	63.26
Terrace Floor	0.00	0.00	0.00	0.00
Total :	126.52	126.52	126.52	126.52

Building USE/SUBUSE Details

Building Name	Building Use	Building SubUse	Building Structure
A (A)	Residential	Residential Bldg/Apartment	Non-Highrise

Building :A (A)

Floor Name	Total Built Up Area (Sq.mt.)	Proposed FAR Area (Sq.mt.) Resi.	Total FAR Area (Sq.mt.)	Total Consumed Additional FAR Area (Sq.mt.)	Tnmt (No.)
Ground Floor	63.26	63.26	63.26	63.26	01
First Floor	63.26	63.26	63.26	63.26	00
Terrace Floor	0.00	0.00	0.00	0.00	00
Total :	126.52	126.52	126.52	126.52	01
Total Number of Same Buildings :	1				
Total :	126.52	126.52	126.52	126.52	01

LTP NAME AND SIGNATURE MANOJ KUMAR SINGH MADA/DFTMN/0023/2019	STRUCTURAL ENG'S NAME AND SIGNATURE	BUILDER NAME AND SIGNATURE	DIGITAL SIGNATURE
---	-------------------------------------	----------------------------	-------------------

Proposal Basic Information	
Proposal File No.	MADA/BP/0003/2020
Owner Name	JAIDEV BANERJEE
Khata No	OLD KHAT NO. 91, NEW - 12, 108
Plot No	OLD PLOT NO. 334, 329 (NEW PLOT NO. - 560, 563)
Village Name	Damodarpur
Use	Residential
SubUse	Bungalow/ Dwelling / Non Apartment

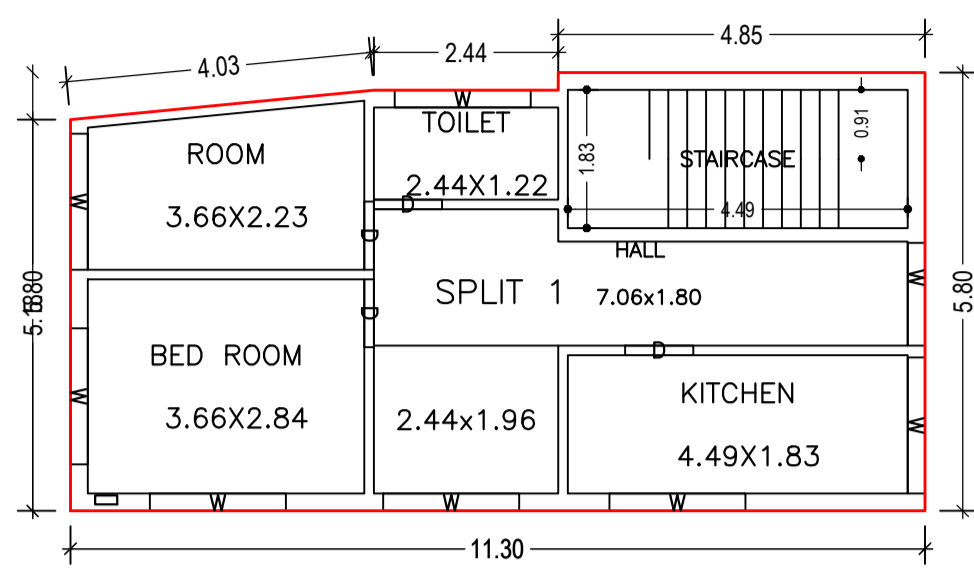

GROUND FLOOR PLAN
(Proposed)
(SCALE 1:100)

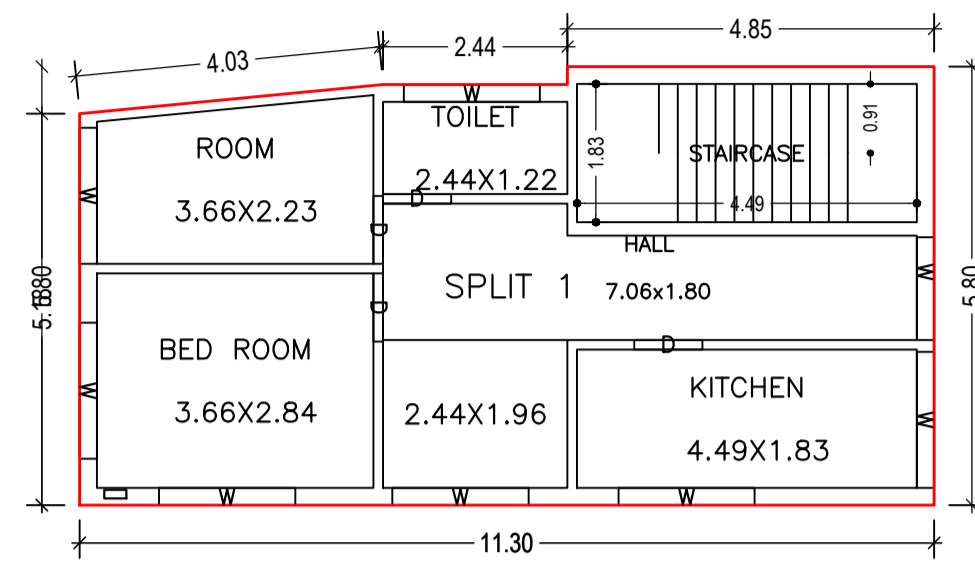

FIRST FLOOR PLAN
(Proposed)
(SCALE 1:100)

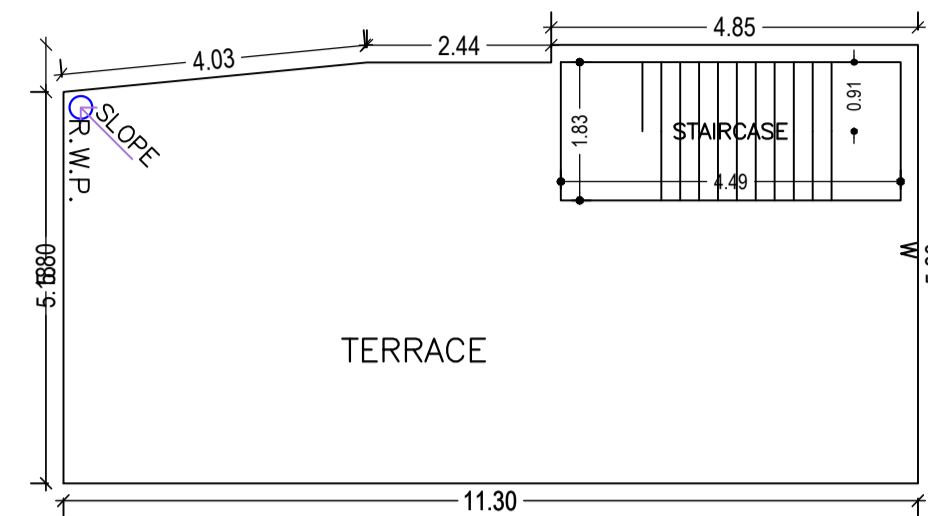

TERRACE FLOOR PLAN
(SCALE 1:100)

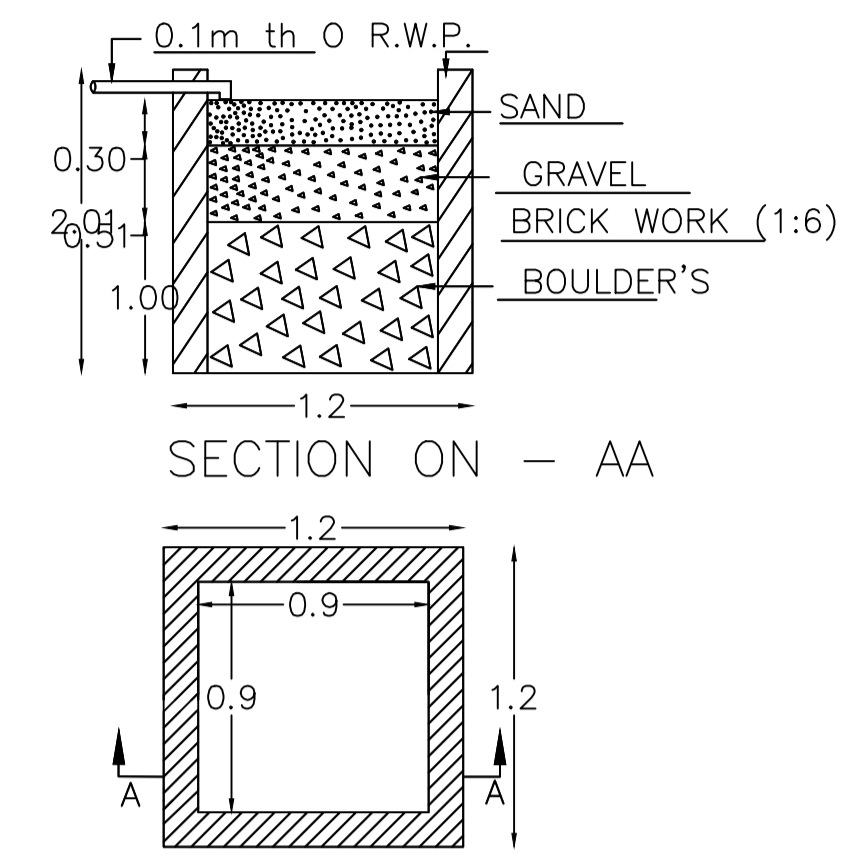

DETAIL'S OF WATER HARVESTING

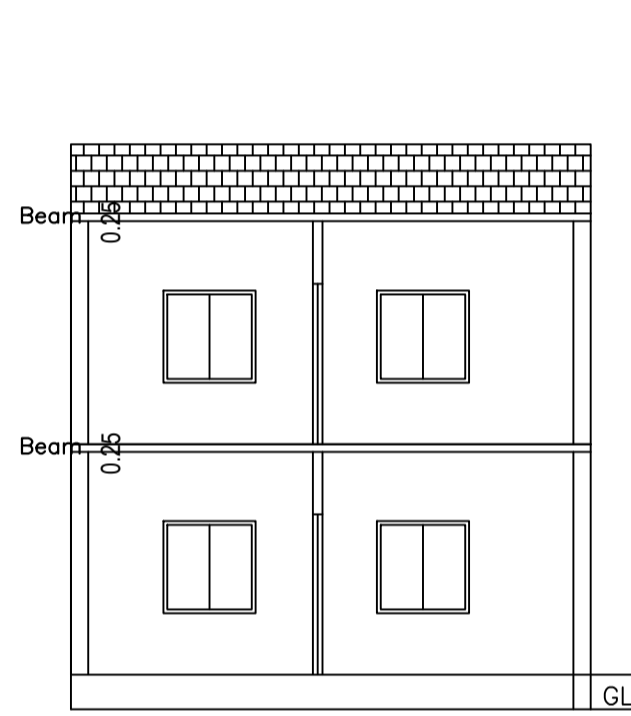

SECTION ON Y-Y

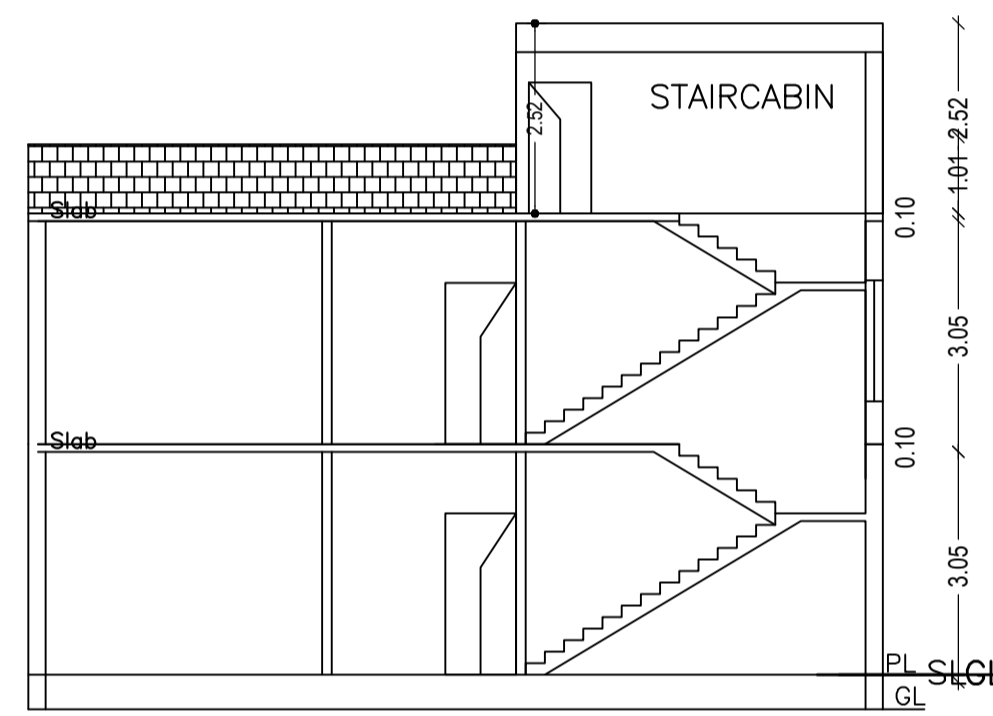

SECTION ON X-X

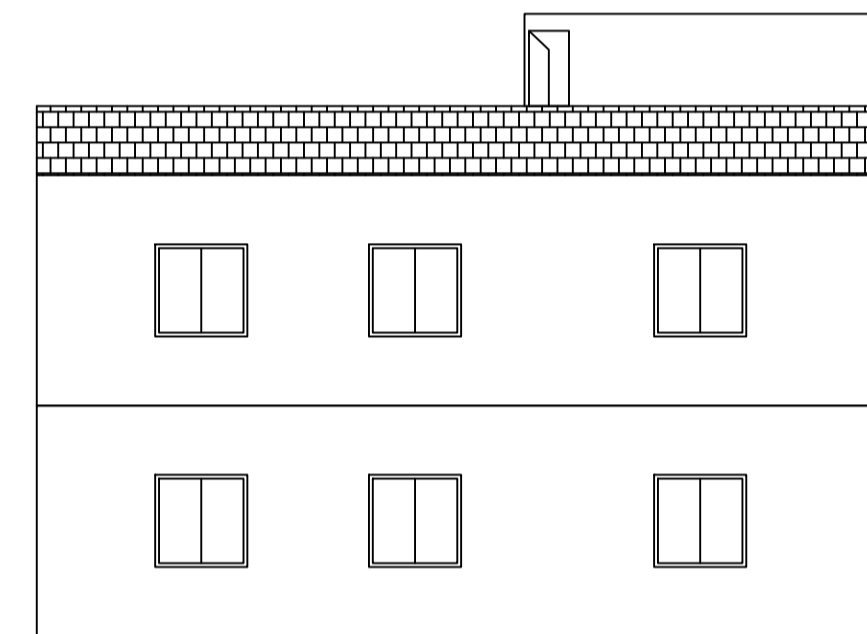

FRONT ELEVATION

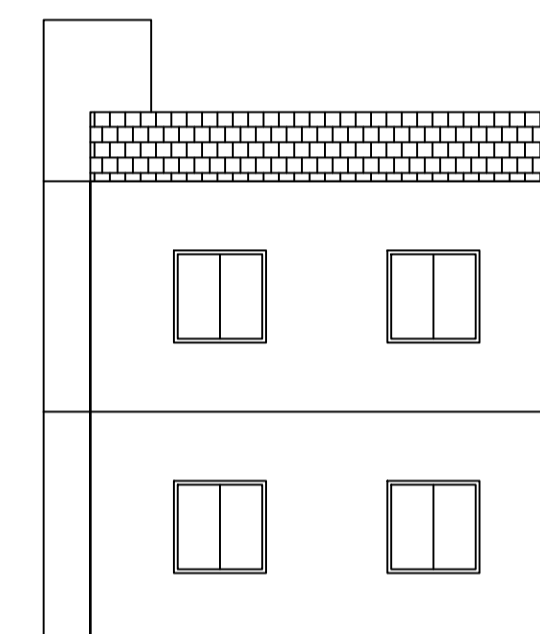

LEFT SIDE ELEVATION

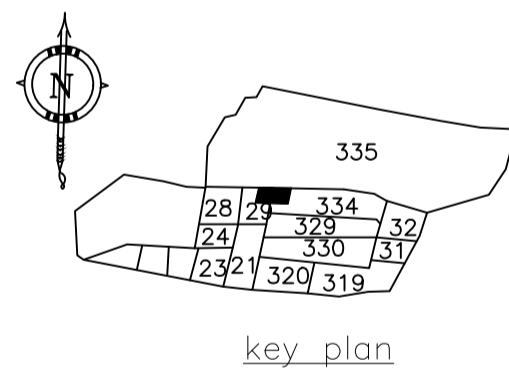

key plan

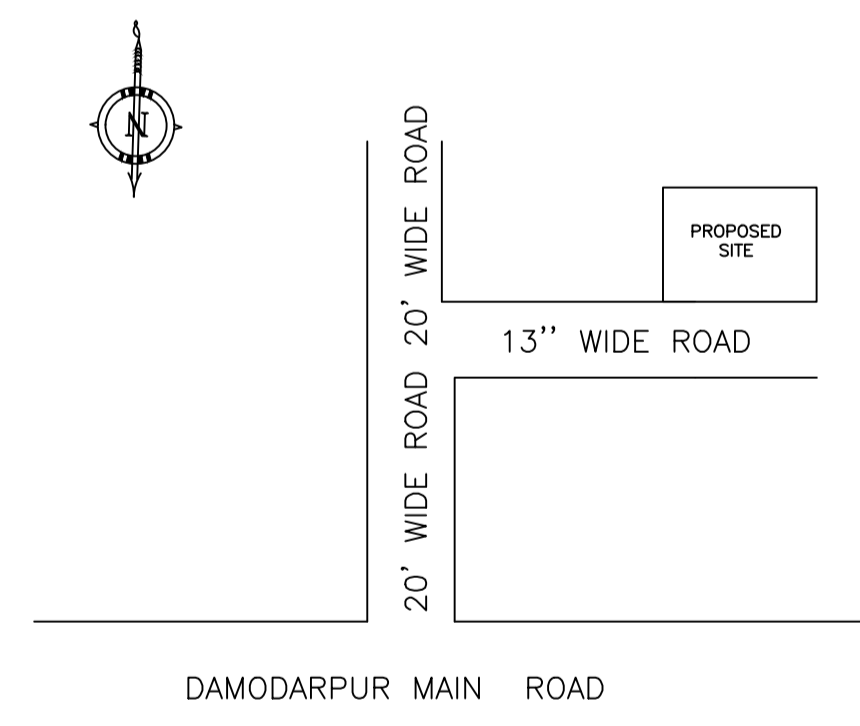

location plan

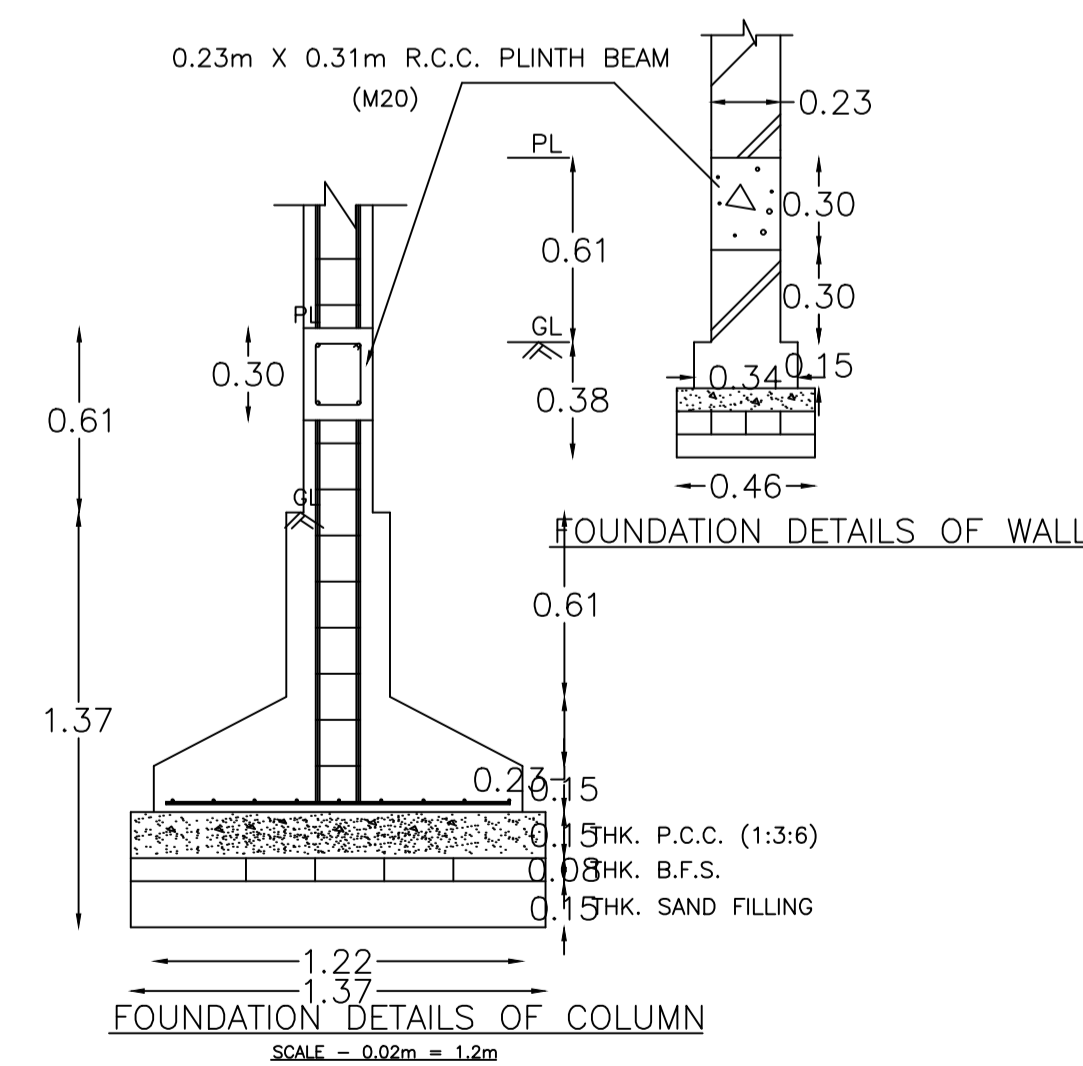

FOUNDATION DETAILS OF COLUMN
SCALE = 0.02m = 1.2m

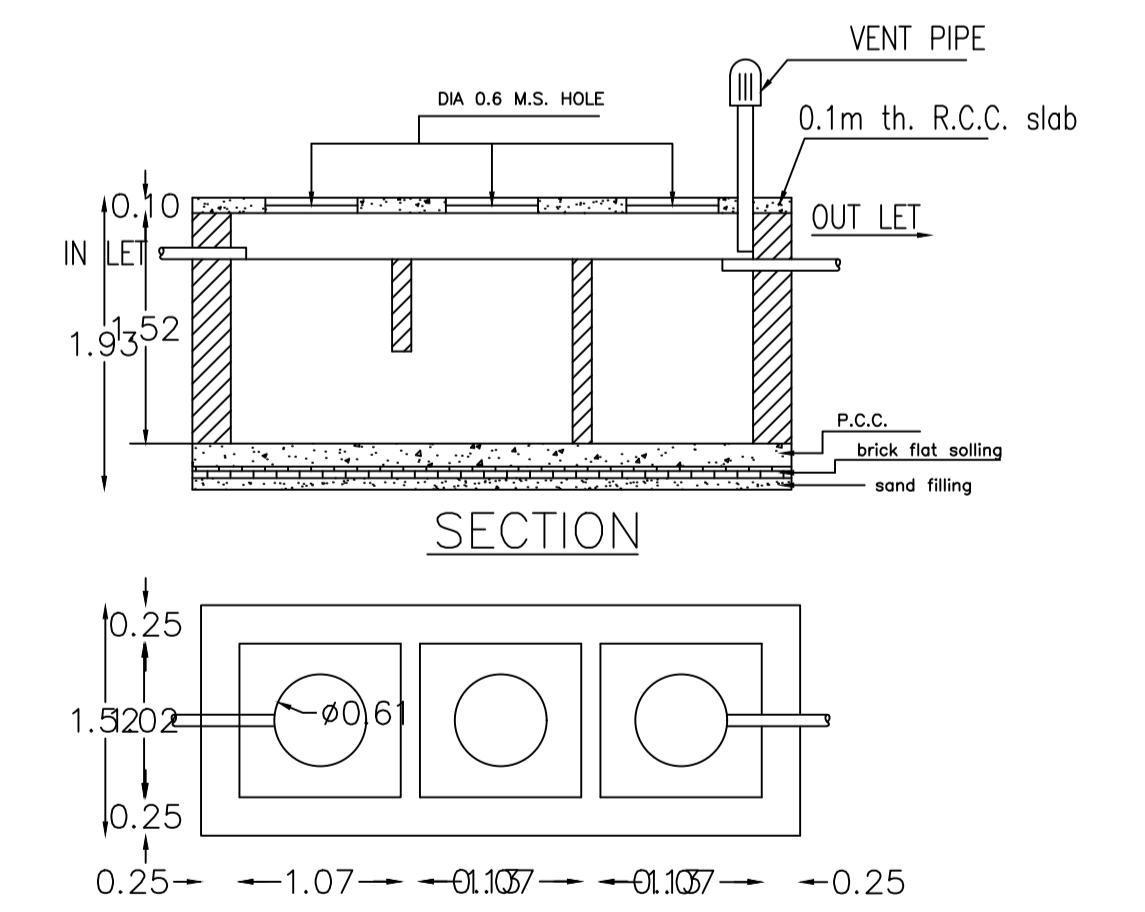

DETAILS OF SEPTIC TANK

LTP NAME AND SIGNATURE	STRUCTURAL ENG'S NAME AND SIGNATURE	BUILDER NAME AND SIGNATURE	DIGITAL SIGNATURE
MANOJ KUMAR SINGH MADA/DFTMIN/0023/2019			